

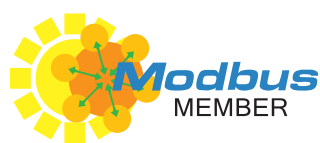

TEX-PRC

Process Controller



The TEX-PRC process controller interfaces smoothly with a wide range of PLC and monitoring systems. Specifically for use in process applications, it accepts 0–20mA, 4–20mA, 0–2V or 0–10V inputs.

This controller has been designed for ease of use, with intuitive, scrolling text prompts that guide you step-by-step through the setup process. The front panel includes 5 buttons, for simple operator interface, and a 6-digit LED display.

Order Codes

TEX-PRC	4–20mA/0–10V Controller
–HV	85–265V AC / 95–370V DC
–LV	15–48V AC / 10–72V DC

Options

–R2	2 x relay outputs
–R4	4 x relay outputs
–A	1 x mA/V analog output
–S2R	1 x RS232 (RJ11 terminal)
–S4S	1 x RS485 (screw terminal)

Contents

1 - Specifications	2
2 - Front Panel & Display	3
3 - Wiring	4
4 - Dimensions & Installation	8
5 - Input Header Adjustment	10
6 - Input Setup & Calibration	12
7 - Setpoint Setup	18
8 - Setpoint Open Access	21
9 - Reset PIN Numbers / View Firmware Version	21
A - Appendix A - Serial Modes	22

1

SPECIFICATIONS

Input

Input signal Current (0–20mA / 4–20mA) or Voltage (0–2V / 0–10V)

Excitation 24V DC (50mA max)

Sampling rate 10Hz

Resolution 16-bit

Accuracy 0.05% of reading

Ambient drift Typically 50ppm/°C

Power

Power supply

HV: 85–265V AC/95–370V DC, or
LV: 15–48V AC/10–72V DC

Relay Output

OPTIONAL

Number of relay outputs None, 2, or 4

Relay output type 5A Form A (3A 240V AC max or 3A 30V DC max)

Analog Output

OPTIONAL

Number of analog outputs None or 1

Analog output type Isolated 16 bit
4–20mA/0–10V

Programming

Front panel buttons Up, Down, P (Prog/Enter), plus 2x Function Buttons for menu access

Calibration Factory set up for 4–20mA. Calibrated for 0/4–20mA and 0–2/10V. Simple header adjustment required for voltage input (see Section 5)

Security Input setup and setpoint functions have independent PIN code access

Display

Display type LED display, 5 buttons

LED indicators 6 setpoint LEDs

Digits 1 row of 6 digits, 13mm (0.5") size, 14-segment alphanumeric LED

Construction

Casing Panel mount case, 5 buttons

Ingress protection rating IP65 dust/splash proof (face only)

Dimensions (H x W x D)

48 x 96 x 120mm (1.89 x 3.78 x 4.72")

Cutout area (H x W)

45 x 92mm (1.77 x 3.62")

2

FRONT PANEL & DISPLAY

2.1 - Front panel

SPX The SP LED's are used to indicate active setpoints.

F1 This button is used to access the **Input Setup & Calibration** menu (Section 6).

P This button is used to save your settings and advance to the next step in the setup process.

↑ This button is typically used to scroll through options or increase values in the setup menu. Pressing this button from the main display allows you to view/reset the **PEAK** value (see 2.3).

↓ This button is typically used to scroll through options or decrease values in the setup menu. Pressing this button from the main display allows you to view/reset the **VALLEY** value (see 2.3).

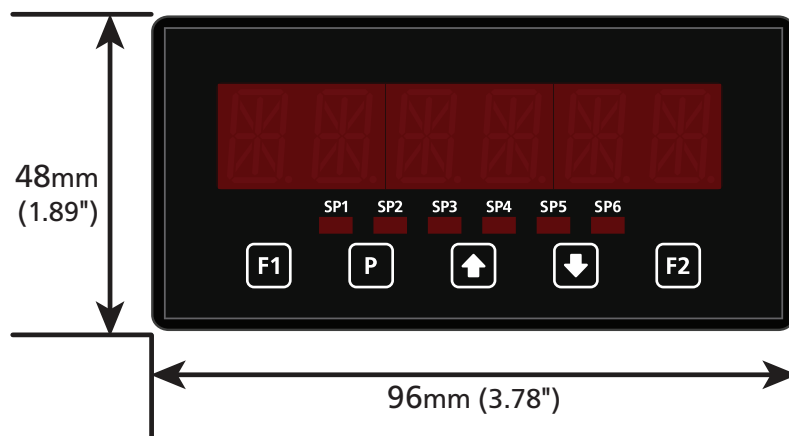

F2 This button is used to access the **Setpoint Setup** menu (Section 7) and the **Setpoint Open Access** menu (Section 8).







2.2 - Display brightness

To adjust the display brightness, press the **P** and **↑** buttons together from the main display. **BRI** appears and toggles with the current setting. Use the **↑** and **↓** buttons to adjust the LED backlight, and then press **P** to finish.

2.3 - Up and down button shortcuts

Pressing the  and  buttons from the main operational display allows instant access to peak and valley values held in the controller's memory, as shown below.

 PEAK	Maximum measured process input since the unit was turned on or reset
 VALLEY	Minimum measured process input since the unit was turned on or reset

PEAK or **VALLEY** may be reset to zero by pressing the  and  buttons **at the same time** while the variable is being displayed. These values may also be reset using the function pins (see 3.6). Press  at any time to return to normal operating mode.

3

WIRING

3.1 - Pinouts

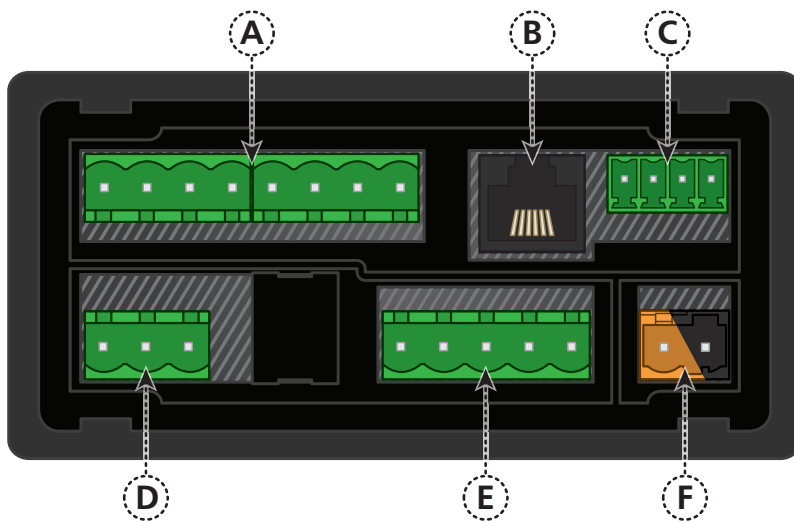

Key

3.1A Relay Output (See 3.3)

3.1B Serial Port (See 3.5)

3.1C Analog Output (See 3.4)

3.1D Analog Input (See 3.2)

3.1E Function Pins (See 3.6)

3.1F Power Supply (See 3.7)

3.2 - Wire the analog input

See 3.1D

The analog input module has an input type header that is configured for 0/4–20mA input by default. **This will need to be adjusted for voltage input applications.**

Ideally you should do this before you continue wiring. Please see Section 5.

Then wire the analog input as required for your application, referring to the diagrams below.

2-wire Current/Voltage Input

External excitation used

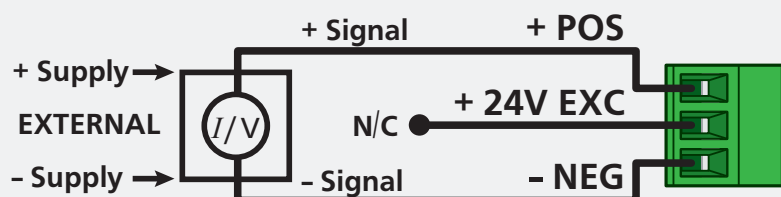

2-wire Current Input

Loop powered sensor

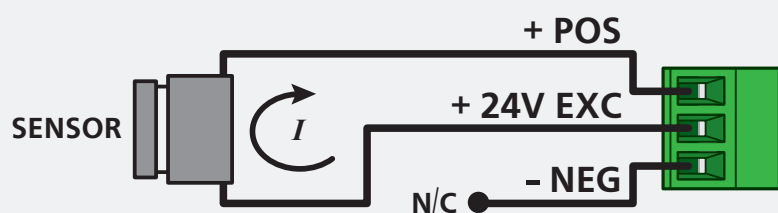

3-wire Current/Voltage Input

Controller supplied excitation

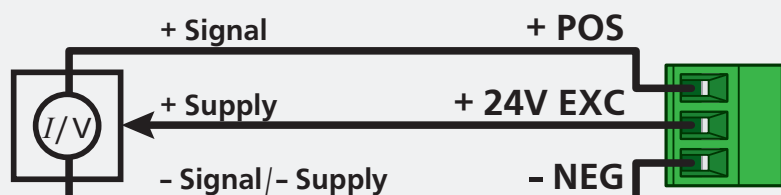

3.3 - Wire the relay outputs

See 3.1A

If your controller has relay outputs fitted, wire them as shown below. Relays can be programmed to operate within the total span range of the controller.

-R2

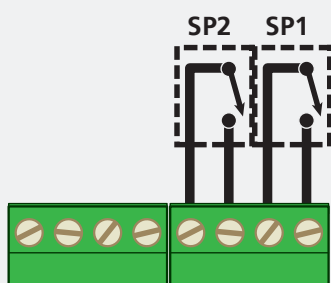

-R4

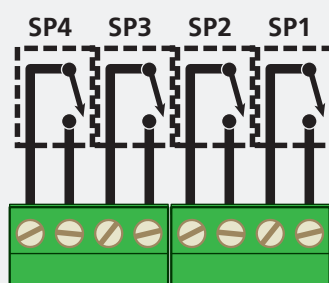

3.4 - Wire the analog output

See 3.1C

If your controller has analog output fitted, wire it as shown for either voltage (0–10V) or current (4–20mA).

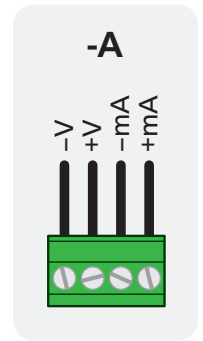

3.5 - Serial port

See 3.1B

If your controller has serial port fitted, wire it as shown in the applicable diagram. (S2R: RS232, RJ11 terminal, S4S: RS485, screw terminal).

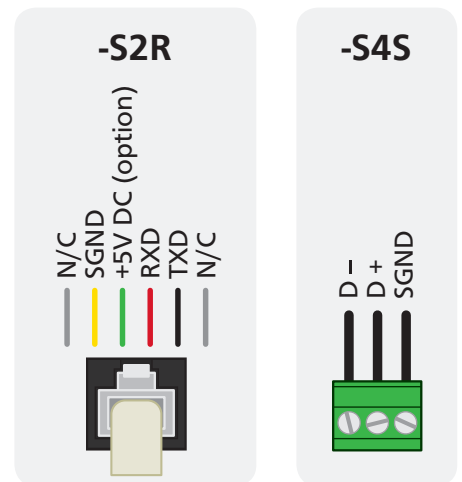

3.6 - Wire the function pins

See 3.1E

Connect external switches to enable a function to be executed when its switch is activated:

- Valley** Clears the **Valley** value (also see 2.3)
- Hold** Holds the current display value
- Test** Resets the meter
- Peak** Clears the **Peak** value (also see 2.3)

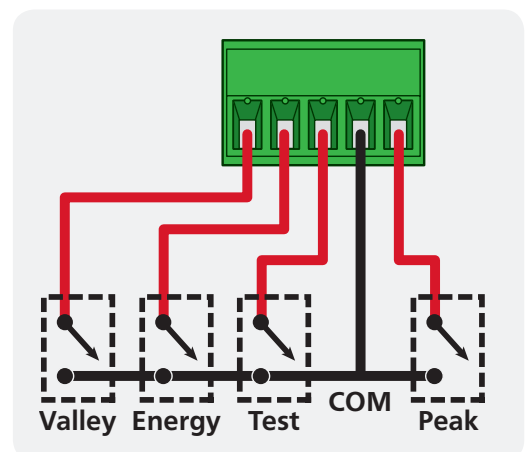

3.7 - Wire the power supply

See 3.1F

DO NOT attempt to wire your controller while the power is on. NEVER connect your low voltage controller to mains power.

Wire your controller for low or high voltage power supply, as show in the diagrams below. Check the label on the unit against the colour of the connector:

- › **Orange =**
High voltage (85–265V AC,
95–370V DC)
- › **Black =**
Low voltage (15–48V AC,
10–72V DC)

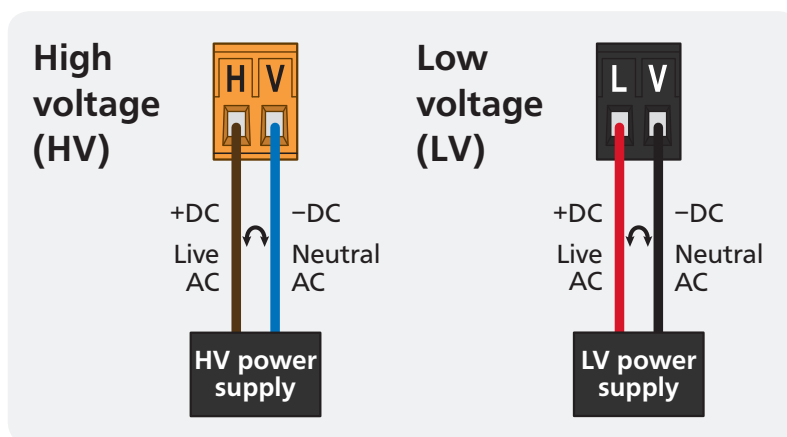

Once you have completed the wiring process it is safe to switch on your power supply. Ensure that your display is functioning before you proceed.

4

DIMENSIONS & INSTALLATION

4.1 - Case dimensions

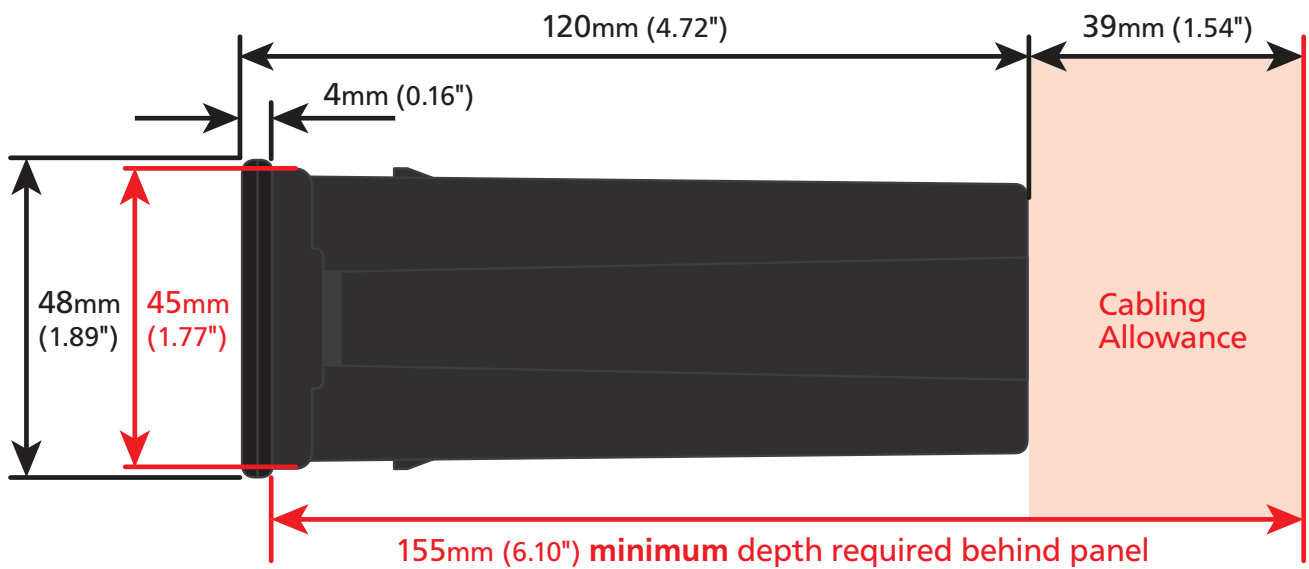
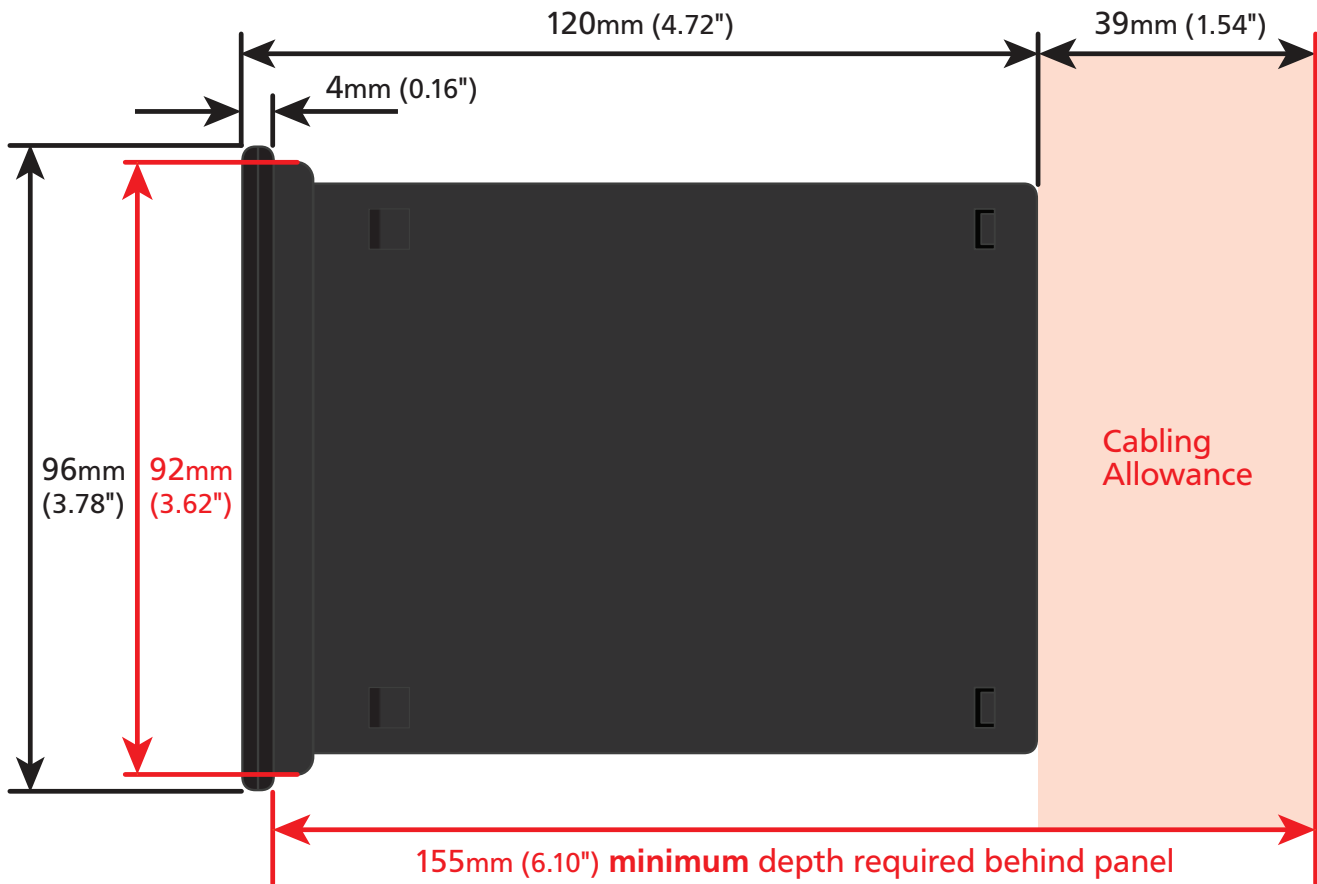

4.2 - Installation instructions

- A** Prepare the **Panel Cutout** to $92 \times 45\text{mm} \pm 0.5$ ($3.62 \times 1.77" \pm 0.02$), as shown below.
Allow at least 155mm (6.10") depth behind the panel to accommodate the meter body, protruding connectors and cabling.
- B** Remove the **Mounting Clips** from the meter back.
- C** Slide the **Panel Gasket** over the rear of the unit to the back of the **Meter Faceplate**.
- D** From the front of the panel, insert the meter into the **Panel Cutout**. Holding the unit in place, engage the **Mounting Clips** so that the tabs snap into place over the notches on the case.
- E** To achieve a proper seal, tighten the **Screws** evenly until the unit sits firmly against the panel. Do not over-tighten the screws.

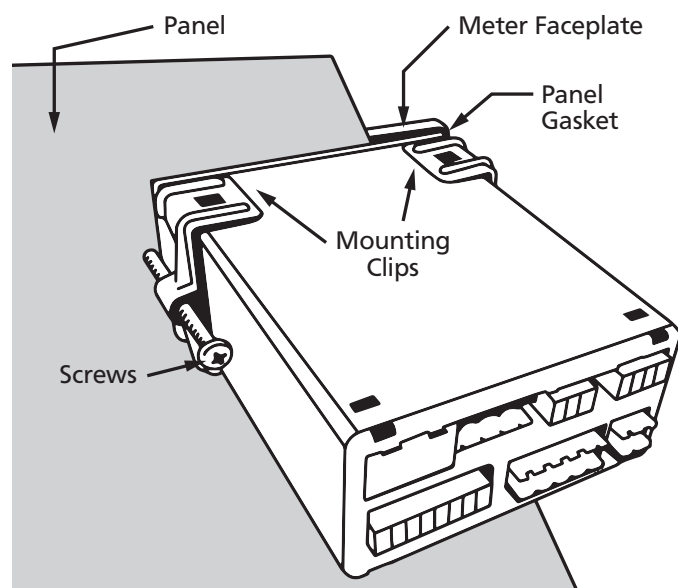

Panel Cutout

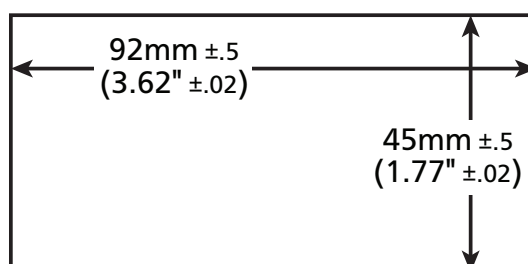

5

INPUT HEADER ADJUSTMENT

The analog input board for the TEX-PRC has a header which can be set to 3 positions, depending on your input type and range, as per the table below:

Header Position	Used For
20mA	0–20mA and 4–20mA input ranges (default setting)
2V	0–2V input range
10V	0–10V input range

5.1 - Do I need to shift the input header?

In most cases the **input header does not need to be changed** from its default position of '20mA' (suitable for 0–20mA and 4–20mA inputs).

You **will** need to shift the input header if:

- › You are using the 0–2V or 0–10V input range, or
- › You are changing your input type back to mA after previous setup for voltage

5.2 - How to shift the input header

A If the meter is already installed, remove it from the panel, and unplug all plugs from the back of the unit.

B Using a small screwdriver or similar implement, press downward into one of the slots at the rear of the case.

This will disengage the tab which holds the back plate on, allowing it to be gently levered away at one corner.

C Holding the loosened corner open with one hand, disengage the lever on the opposite slot.

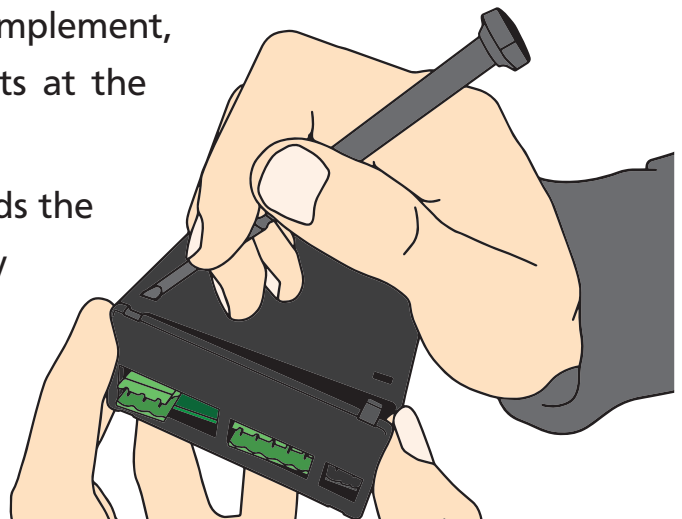

D You should now be able to remove the back plate. If it does not unclip easily, you may need to disengage the two remaining tabs by repeating steps 5.2B–C on the other side of the meter.

E Slide the analog input module out of the meter case. (See 3.1D to identify the input module.)

F Position the header on the input module as required for your input type and range:

- › **20mA** 0–20mA & 4–20mA
- › **Custom** Not used
- › **2V** 0–2V
- › **10V** 0–10V

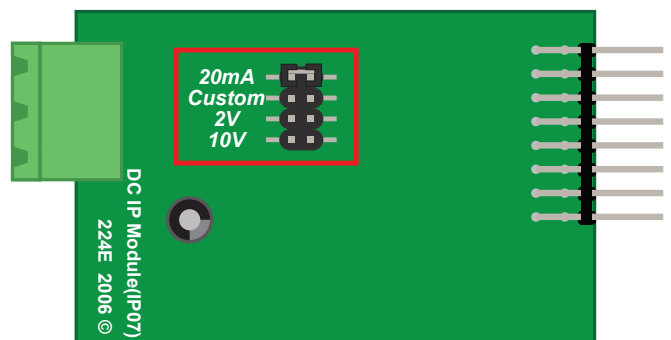
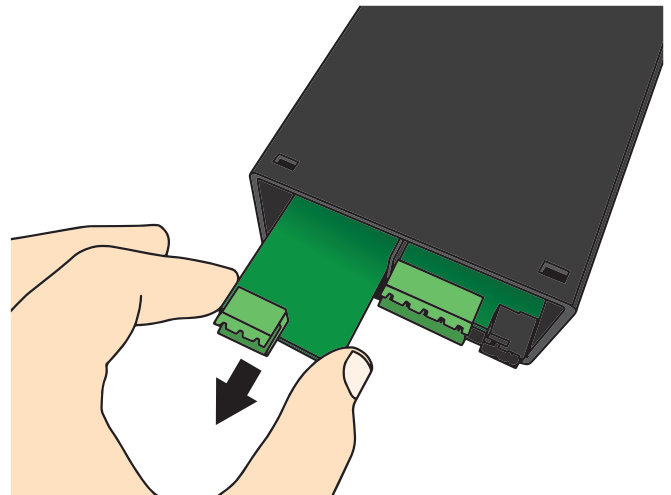

Note that you will also need to change the *Input Mode* in software from the front panel - see 6.2C.

G Slide the input module back into the meter case.

Make sure that it is sitting in the tracks on the left and right. Press firmly until the input module is fully inserted and sits flush with the other boards that are visible from the back of the meter.

H Replace the back plate.

Begin by inserting the two lower tabs into the slots, and then position the upper tabs so that they will not catch on the top lip of the meter case. Apply firm pressure until the back plate clicks into place.

I Reconnect the plugs and return the meter to the panel installation.

Don't forget that once the unit is connected and powered up, you will need to enter the **Input Setup** menu (6.2) and confirm that the correct *Input Mode* is also selected (see 6.2C).

6

INPUT SETUP & CALIBRATION

6.1 - Enter Cal PIN number

A Enter the calibration mode by pressing the **F1** button.

___ **ENTER CAL PIN NUMBER** scrolls across the display and toggles with **0**. Use the **▲** and **▼** buttons to enter your security code (factory default '1'). Then press **P**. If the correct PIN is entered, setup is started at 6.2.

If an incorrect PIN number is entered, ___ **INCORRECT PIN NUMBER – ACCESS DENIED** scrolls across the display and it returns to normal operating mode.

You will have the opportunity to change your PIN number at the end of this section (6.7). If you have forgotten your PIN number, see Section 9.

6.2 - Input setup

A ___ **INPUT SETUP** scrolls across the display and toggles with **SKIP**. Press **P** to skip to 6.3, or the **▲** button and then **P** to **ENTER** input setup.

B ___ **MAINS FREQUENCY** scrolls across the display. Use the **▲** and **▼** buttons to select **50HZ** or **60HZ**, and then press **P**.

C ___ **INPUT MODE** scrolls across the display and toggles with the currently selected input mode. Use the **▲** and **▼** buttons to select: **4–20MA**, **0–20MA 2V (0–2V)** or **10V (0–10V)**. Then press **P**.

*Note that if you change the **INPUT MODE** in this step, then the input header on the analog input module may also need to be changed. See Section 5 for more information.*

D ___ **DECIMAL POINT POSITION** scrolls across the display and toggles with the current selection. Use the **▲** and **▼** buttons to select **NO DP** (no decimal point), **0.1**, **0.12**, **0.123**, or **0.1234**, and then press **P**.

E ___ **DISPLAY ROUNDING** scrolls across the display and toggles with the selected rounding. Using the **▲** and **▼** buttons, select: **NONE**, **2**, **5**, or **10**. Press **P**.

*Rounding is quoted in display counts and is not influenced by decimal point position. For example, if your input signal is 5.3mA, the display will show: 5.3 (for rounding=**NONE**), 5.4 (for rounding=**2**), 5.5 (for rounding=**5**), or 5.0 (for rounding=**10**).*

6.3 - Calibration

A **___ CALIBRATION TECHNIQUE** scrolls across the display and toggles with **SKIP**. Press **P** to skip to 6.4, or use the **▲** and **▼** buttons to select a calibration method: either **AUTO**, **MANUAL**, or **S.G.** (secific gravity). Then press **P**.

- ➔ If you selected **AUTO**, complete steps 6.3B–D now.
- ➔ If you selected **MANUAL**, complete steps 6.3E–F now.
- ➔ If you selected **S.G.**, complete steps 6.3G now.
- ➔ If you selected **SKIP**, skip to 6.4 now.

AUTO (key-in) calibration uses zero and span values to calculate the scale and offset. This is the most accurate calibration method, but requires known low and high input signals (or the use of a calibrator).

MAN The manual calibration procedure uses low and high display values, and is intended for a pre-calibrated sensor with a known output range. (For example 4mA=0 and 20mA=1000.) It does not require any input signals to be applied to the controller during calibration.

S.G. The specific gravity calibration procedure allows the user to enter a scale factor which is used to compensate for changes in the specific gravity of different substances. **This does not constitute a full calibration and assumes that either an automatic or manual calibration has been applied previously with the S.G. value set to 1.0.**

Auto calibration



B **___ APPLY LOW INPUT SIGNAL – – – – ENTER LOW DISPLAY VALUE** scrolls across and toggles with the current selection. Apply the required low input signal, and wait a moment for the signal to stabilise. Then, using the **▲** and **▼** buttons, enter your low display value, and press **P** to accept and continue.

C **___ APPLY HIGH INPUT SIGNAL – – – – ENTER HIGH DISPLAY VALUE** scrolls across and toggles with the current selection. Apply the required high input signal, and wait a moment for the signal to stabilise. Then, using the **▲** and **▼** buttons, enter your high display value, and press **P**.



- D** If Auto calibration was successful, you will be directed out of the calibration menu to the operational display without viewing any further scrolling messages. (To proceed to step 6.4, you must select **SKIP** at 6.3A.)

If calibration fails, **___ CALIBRATION FAILED** will scroll across the display and you will be directed back to the operational display. The most likely cause of this error is that the controller could not detect any change in input signal during calibration. Check your signal and connections, and repeat the procedure.

Manual calibration

- E** **___ ENTER DISPLAY VALUE FOR [LOW MA/V]** scrolls across the display, and toggles with the current low display value. Use the  and  buttons to adjust the display value for the low level input signal. Then press .



*The text string for [LOW MA/V] is determined by your **INPUT MODE** (selected in 6.2C): **0MA** (for 0–20mA), **4MA** (for 4–20mA) or **0V** (for 0–2V/0–10V).*

- F** **___ ENTER DISPLAY VALUE FOR [HIGH MA/V]** scrolls across the display, and toggles with the current high display value. Use the  and  buttons to adjust the display value for the high level input signal. Then press .

*The text string for [HIGH MA/V] is determined by your **INPUT MODE** (selected in 6.2C): **20MA** (for 0/4–20mA), **2V** (for 0–2V) or **10V** (for 0–10V).*

Manual calibration is now complete. You will be directed back to the operational display. (To proceed to step 6.4, you must select **SKIP** at 6.3A.)

Specific gravity

- G** **___ SPECIFIC GRAVITY** scrolls across and toggles with the current specific gravity scale factor. Adjust this value using the  and  buttons, and then press  to accept and return to the operational display.

(To proceed to step 6.4, you must select **SKIP** at 6.3A.)

*The specific gravity calibration procedure allows the user to enter a scale factor which is used to compensate for changes in the specific gravity of different substances. **This does not constitute a full calibration and assumes that either an automatic or manual calibration has been applied previously with the S.G. value set to 1.0.***

6.4 - Averaging

Your controller has input signal averaging, optimising stable measurement.

If the change in input exceeds the averaging window value it will not average, ensuring fast response when there are large differences between readings.

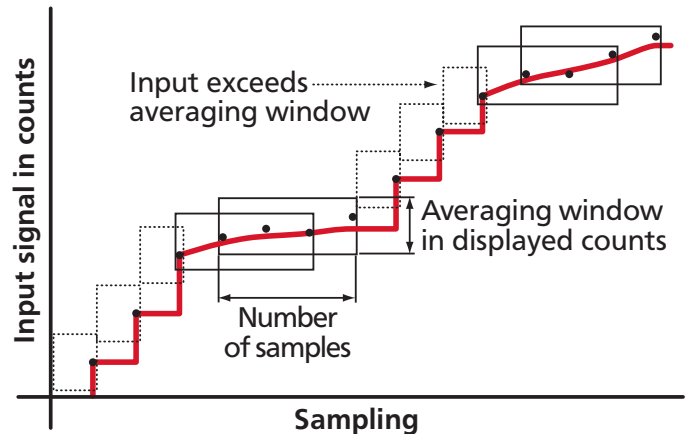

A ___ **AVERAGING PARAMETERS** scrolls across and toggles with **SKIP**. Press **P** to skip to 6.5, or the **▲** button and then **P** to **ENTER** averaging setup.

B ___ **AVE SAMPLES** scrolls across the display and toggles with the currently selected averaging. Using the **▲** and **▼** buttons, alter the number of input samples that the controller will average, and then press **P**.









Increasing the number of samples will stabilise measurement, but it will also slow down response rates. A typical value is 4.

C ___ **AVE WINDOW** scrolls across the display and toggles with the currently selected averaging window value. Using the **▲** and **▼** buttons, alter the signal averaging window. Then press **P**.

*If your input signal contains large noise spikes, you can increase the size of the averaging window to ensure that these are still averaged. However, increasing the window size too far will reduce the ability of the controller to respond quickly to real changes in input signal. Setting **AVE WINDOW** to 0 will give continuous averaging as per the selected averaging samples. A typical value is 10% of your system capacity.*







6.5 - Analog output setup

A ___ **ANALOG OUTPUT SETUP** scrolls across the display and toggles with **SKIP**. If your controller does not have analog output installed, (or you do not wish to configure your analog output now), press **P** to skip to 6.7. Otherwise, press the **▲** button and then **P** to **ENTER** analog output setup.

- B** ___ **LOW SCALE VALUE FOR ANALOG OUTPUT** scrolls across the display and toggles with the currently selected low scale display value. Use the  and  buttons to enter your cal low position, and then press .
- C** ___ **HIGH SCALE VALUE FOR ANALOG OUTPUT** scrolls across the display and toggles with the currently selected high scale display value. Use the  and  buttons to enter your cal high position, and then press .
- D** ___ **CALIBRATE ANALOG OUTPUT?** scrolls across the display and toggles with **SKIP**. Press  now to skip analog output calibration and continue to 6.7, or the  button and then  to **ENTER**.



Factory analog output calibration is precisely set before shipping this instrument, and should not be adjusted unless advised by the manufacturer.













- ➔ If you selected **ENTER**, connect a mA or volt meter across the analog output connector (see 3.1C), and then continue to 6.5E.
- ➔ If you selected **SKIP**, go to 6.7 now.

- E** ___ **CAL LOW ANALOG OUTPUT** scrolls across and toggles with a calibration number, displayed in internal units (mA/V). Using the  and  buttons, calibrate your low analog output as required, and press .
- F** ___ **CAL HIGH ANALOG OUTPUT** scrolls across and toggles with a calibration number, displayed in internal units (mA/V). Using the  and  buttons, calibrate your high analog output as required, and press .

Analog output calibration is now complete. The display will return to normal operating mode.

6.6 - Serial setup







- A** ___ **SERIAL SETUP** scrolls across the display and toggles with **SKIP**. If your unit does not have a serial port installed, (or you do not wish to configure your serial options now), please press  to skip to 6.7.
- Otherwise, press the  button and then  to **ENTER** serial setup.

-
- B** **___ SERIAL MODE** scrolls across the display and toggles with the currently selected serial mode. Using the  and  buttons, choose either: **ASCII** (custom), **MODBUS (RTU)** or **RNGR A (Ranger A)**, and then press .
- C** **___ BAUD RATE** scrolls across the display and toggles with the current selection. Use the  and  buttons to select one of: **300, 600, 1200, 2400, 4800, 9600, 19200** or **38400**. Then press .
- D** **___ PARITY** scrolls across the display and toggles with the current selection. Using the  and  buttons, select: **NONE, ODD** or **EVEN**, and then press .
- E** **___ SERIAL ADDRESS** scrolls across the display and toggles with the current address. Use the  and  buttons to alter the serial address, and press .

*The serial address parameter is used to identify a particular device when it is used with other devices in a system. (It applies particularly to **MODBUS** mode when used on an RS485 serial network.) The serial address of the controller must be set to match the serial address defined in the master device.*

Refer to Appendix A for more information on serial modes and registers.

6.7 - Edit Cal PIN number

- A** **___ EDIT CAL PIN NUMBER** scrolls across the display and toggles with **SKIP**. Press  to skip and return to the operational display, or the  button and then  to **ENTER** and change your PIN number.
- B** **___ ENTER NEW CAL PIN NUMBER** scrolls across the display and toggles with the current PIN (default 1). Using the  and  buttons, enter your new calibration PIN number. Then press  to exit to the operational display.

7

SETPOINT SETUP

The software in your controller will allow you to configure up to 6 setpoints, however full functionality is only supported when relay output hardware is installed.

(Setpoints with no corresponding relay output hardware may be used as simple LED indicators, if desired. In this case, features requiring relay output functionality will continue to appear in the setup menu, but will be ignored by the controller.)

7.1 - Enter Setpoint PIN number

- A** Enter setpoint setup mode by pressing and holding the **F2** button for 3 seconds. **___ ENTER SP PIN NUMBER** scrolls across the display and toggles with **0**. Use the **↑** and **↓** buttons to enter your security code (factory default '1'). Then press **P**. If the correct PIN is entered, setup is started at 7.2. If an incorrect PIN number is entered, **___ INCORRECT PIN NUMBER – ACCESS DENIED** scrolls across the display and it returns to normal operating mode.

You will have the opportunity to change your PIN number at the end of this section (7.3). If you have forgotten your PIN number, see Section 9.

7.2 - Setpoint setup

- A** **___ EDIT SETPOINT** scrolls across the display and toggles with **SKIP**. Press **P** now to skip to 7.3, or use the **↑** and **↓** buttons to select a setpoint to edit, and then press **P**.
- B** **___ SP VALUE** scrolls across the display and toggles with the current value for the selected setpoint. Using the **↑** and **↓** buttons, adjust the display value at which the selected setpoint will activate, and then press **P**.
- C** **___ SP ACTIVATION** scrolls across the display and toggles with the current activation for the selected setpoint. Using the **↑** and **↓** buttons, select the relay

activation to operate **ABOVE** or **BELOW** the setpoint value, and then press **P**.

ABOVE: Relay turns on above the setpoint value and off below it.

BELOW: Relay turns on below the setpoint value and off above it.

- D** **___ SETPOINT TYPE** scrolls across the display and toggles with the current setting for the selected setpoint. Using the **↑** and **↓** buttons, select either **ALARM** or **CNTRL** (control), and then press **P**.

ALARM - SETPOINT VALUE controls setpoint activation point. **HYSTERESIS VALUE** controls setpoint deactivation point.

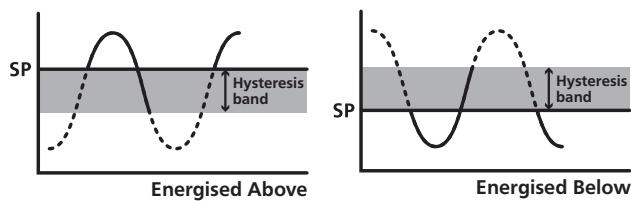

CNTRL - SETPOINT VALUE controls setpoint deactivation point. **HYSTERESIS VALUE** controls setpoint reactivation point.

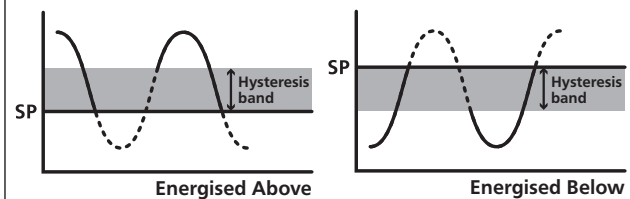

- E** **___ HYSTERESIS VALUE** scrolls across the display and toggles with the hysteresis value for the selected setpoint. Use the **↑** and **↓** buttons to adjust this value if required, and then press **P**.

*The **HYSTERESIS VALUE** defines the separation band between setpoint activation and deactivation, and will operate as per the **SETPOINT TYPE** setting selected in 7.2D.*





- F** **___ MAKE DELAY** scrolls across the display and toggles with the current make delay time for the selected setpoint. This is the time delay between setpoint activation, and when the relay turns on. Adjust this value in 0.1 second increments using the **↑** and **↓** buttons, and then press **P**.

- G** **___ OPEN ACCESS TO SP VALUE** scrolls across the display and toggles with the open access permission setting for the selected setpoint. Use the **↑** and **↓** to select either **YES** or **NO**, and then press **P**.







*When enabled, this option allows the selected setpoint's value to be edited directly after pressing the **F2** button, without needing to enter a PIN number or go through all of the other options. Each setpoint can individually have this option enabled or disabled. See Section 8.*

- H** The step that you proceed to now will depend on which setpoint you are editing (selected in 7.2A):

- ➔ If you are currently editing **SP 1**, skip to 7.2J now.
- ➔ If you are currently editing **SP 2–4**, continue to 7.2I now.

- I **___ TRAIL SP1** scrolls across the display and toggles with the trailing setting for the selected setpoint. A setpoint with **TRAIL SP1** enabled will trail the *SP Value* of **SP 1**. (The setpoint value of the trailing setpoint will effectively become an offset value.)
Using the  and  buttons, turn trailing **OFF** or **ON**, and then press .
- J **___ EDIT SETPOINT** scrolls across the display and toggles with **SKIP**. You are now back at 7.2A. To edit another setpoint, follow the instructions from 7.2A–J again. If you do not wish to edit another setpoint, press  now to skip to 7.3.

7.3 - Edit SP PIN number

- A **___ EDIT SP PIN NUMBER** scrolls across the display and toggles with **SKIP**. Press  to skip and return to the operational display, or the  button and then  to **ENTER** and change your PIN number.
- B **___ ENTER NEW SP PIN NUMBER** scrolls across the display and toggles with the current PIN (default 1). Using the  and  buttons, enter your new SP PIN number. Then press  to exit to the operational display.

8

SETPOINT OPEN ACCESS

If none of the setpoints have their open access option enabled then this feature will be disabled and the **F2** button will not respond to a short button press. (See 7.2G.)

- A Begin by pressing the **F2** button for less than 3 seconds.
- B The name of the first access-enabled setpoint will appear on the display and toggle with the current value for that setpoint. Using the **↑** and **↓** buttons, adjust the selected value. Then press **P** to accept and continue.
- C The name of the next access-enabled setpoint will appear on the display, along with its setpoint value. Repeat step 8B. The open access menu will proceed through all access-enabled setpoints in this fashion. Pressing **P** for the last enabled setpoint will exit and return to the operational display.

9

RESET PIN NUMBERS / VIEW FIRMWARE VERSION

If you have forgotten your PIN number(s), follow the procedure below to reset both the Calibration and Setpoint PINs to their factory default of 1.

This procedure will also allow you to view the current software installed on your device, which may be required for support purposes.

- A Press **↑**, **↓** and **P** at the same time. (This key combination can be difficult to execute and you may need several tries to get it right.)
- B A message will appear on the display, with details of the unit's current software configuration (Product name, Firmware Version, and Macro Version etc). At the end, you will see **___ ALL PIN NUMBERS RESET TO 1.**
- C Both the Cal PIN number and the SP PIN number have now been reset to '1'. You can change this, if required, by following the instructions in 6.7 (for Cal) and 7.3 (for SP), using '1' to enter each menu initially.

A.1 - Custom ASCII mode

Custom ASCII is a simple, custom protocol that allows connection to various PC configuration tools. ('Custom ASCII' differs from the 'Modbus (ASCII)' protocol used by some devices.) Custom ASCII command strings must be constructed in this order:

**<Start> <Controller Address> <Read/Write Command> <Register Address>
<Separator Character> <Data Value> <Message Terminator>**

Start - Use 'S' for the start character of a command string (not case sensitive). This must be the first character in the string.

Controller Address - Use an ASCII number from '1' to '255' for the controller address. If the character following the start character is not an ASCII number, then address '0' is assumed. All controllers respond to address '0'.

Read/Write Command - Use ASCII 'R' for read, 'U' for unformatted read, or 'W' for write (not case sensitive). Any other character aborts the operation.

In Custom ASCII mode, data is normally read as formatted data (which includes decimals and any text characters that may be selected to show units). However it is also possible to read unformatted data by using a 'U' in the read command. There is no unformatted write command, as when writing to fixed point registers, any decimal point and text characters are ignored.

Register Address - The register address for the read/write operation will be an ASCII number from '1' to '65535'. This character must be specified for a write command, but may be omitted for a read command, (in which case the controller will respond with the data value currently on the display).

Separator Character - The separator character can be either a space or a comma, and is used to separate the register address from the data value.

Data Value - Must be an ASCII number. The absolute limits for this number are -1000000 to +1000000, but note that not all registers will accept this range.

Message Terminator - This is the last character, and must be either a '\$' (dollar) or an '*' (asterisk). Neither of these characters should be used elsewhere in the message string. If '\$' is used, a 50ms minimum delay is inserted before a reply is sent. If '*' is used, a 2ms minimum delay is inserted before a reply is sent.

Custom ASCII Read/Write Examples

Example	Description
SR\$	Read display value from all controllers, 50ms delay.
S15R\$	Read display value from controller address 15, 50ms delay.
S3U40*	Read unformatted data in channel 4 from controller address 3, 2ms delay.
S2W2 -10000\$	Write -10000 to the display register of controller address 2, 50ms delay.
SWT CHAN_1\$	Write ASCII text string Chan_1 to channel 1 text register, 50ms delay.

Custom ASCII Registers

16 Bit Unsigned		32 Bit Signed	
Address	Function	Address	Function
1	Alarm status (SP1=Bit 0, SP2=Bit 1, SP3=Bit 2, SP4=Bit 3, SP5=Bit 4, SP6=Bit 5)	2	Process display
65-70	Hysteresis (SP1=65, SP2=66, SP3=67, SP4=68, SP5=69, SP6=70)	12	Peak
71-76	Make delay (SP1=71, SP2=72, SP3=73, SP4=74, SP5=75, SP6=76)	13	Valley
		6-11	Setpoint 1-6 (SP1=6, SP2=7, SP3=8, SP4=9, SP5=10, SP6=11)
		34	D/A scale low value
		36	D/A scale high value

Controller Response - After the controller has completed a read or write instruction, it responds by sending a carriage return/line feed (CR/LF) back to the host. If the instruction was a read command, the CR/LF follows the last character in the ASCII string. If it was a write command, CR/LF is the only response sent back. The host must wait for this before sending further commands to the controller. If the controller encounters an error, it will respond with a null (0x00) CR/LF.

A.2 - Modbus (RTU) mode

Modbus (RTU) is an industry standard RTU slave mode that allows connection to a wide range of devices. Modbus registers are all holding registers, and should be accessed via function codes 3 and 6.

Register addresses are displayed in the Modicon™ 5-digit addressing format. I.e. Register 65=40065 (subtract 1 for direct addressing).

Modbus (RTU) Registers

16 Bit Unsigned		32 Bit Signed (2 x 16 Bit)		
Address	Function	LSW	MSW	Function
40001	Alarm status (SP1=Bit 0, SP2=Bit 1, SP3=Bit 2, SP4=Bit 3, SP5=Bit 4, SP6=Bit 5)	40513	40514	Process display
40065– 40070	Hysteresis (SP1=40065, SP2=40066, SP3=40067, SP4=40068, SP5=40069, SP6=40070)	40525	40526	Peak
40071– 40076	Make delay (SP1=40071, SP2=40072, SP3=40073, SP4=40074, SP5=40075, SP6=40076)	40527	40528	Valley
		40535	40536	Setpoint 1–6 (SP1=40535, SP2=40537, SP3=40539, SP4=40541, SP5=40543, SP6=40545)
		–541	–542	
		40587	40588	D/A scale low value
		40591	40592	D/A scale high value

A.3 - Ranger A mode

Ranger A is a continuous output, used to drive remote displays and other instruments in the Rinstrum™ range. (Ranger is a trade name belonging to Rinstrum Pty Ltd.) Ranger A output strings are constructed as shown:

<Start> <Sign> <Output Value> <Status> <End>

Start - STX character (ASCII 02)

Sign - Output value sign (space for + and dash for -)

Output Value - Seven character ASCII string containing the current output value and decimal point. (If there is no decimal point, then the first character is a space. Leading zero blanking applies.)

Status - Single character output value status. 'U'=Under, 'O'=Over, 'E'=Error.

End - ETX character (ASCII 03)



Define Instruments

New Zealand (Head Office)

 10B Vega Place, Rosedale,
Auckland 0632, New Zealand
PO Box 245 Westpark Village,
Auckland 0661, New Zealand

Ph: +64 (9) 835 1550 | **Aus:** 1800 810 820

Fax: +64 (9) 835 1250

 sales@defineinstruments.co.nz

www.defineinstruments.co.nz

United States (Dallas, TX)

Ph: (214) 926 4950

 sales@defineinstruments.com

www.defineinstruments.com

South Africa (Pretoria)

 sales@defineinstruments.co.za

www.defineinstruments.co.za