Measurement made easy

The first choice for all industrial applications

Diagnostics for real-life situations

- To keep your process up and running
- Gas bubble, partial filling or empty pipe detection, electrode impedance, conductivity and sensor temperature monitoring
- Clear text messages for simplified troubleshooting

On board health check

- Flowmeter sensor and transmitter integrity check utilizing fingerprint technology

Noise / Grounding check

- Verify the installation is correct from day one

Service interval monitoring

- Receive timed notifications

Backwards compatibility

- Protect your investment in ABB flowmetering

ProcessMaster series

ProcessMaster is available in two series – ProcessMaster 610 the good fit for everyday applications and ProcessMaster 630 the first choice for all process industry applications delivering best in class functionality and options.

Applicability	FEP610 series	FEP630 series
	Good fit for everyday applications	The first choice for all industrial applications
Chemical Industry Corrosive liquids, acids, bases	✓	✓
Power Coal slurry, Lime slurry, Cooling	✓	✓
Mining Abrasive slurries, hydraulic transport	✓	✓
Pulp & Paper Stock Flows, Latex, Clay, Liquor, Chemicals	Up to 2 % Stock	Up to 4 % Stock
Oil & Gas High pressure applications	✓	✓
Food & Beverage Hygienic applications	✓	✓
Measuring medium minimum conductivity	20 µS/cm	5 µS/cm
Measuring medium temperature	Up to 130 °C (266 °F)	Up to 180 °C (356 °F)
Pressure	≤ PN 40 / CI 300	≤ PN 40 / CI 300, option for high pressure
Hazardous area	–	Yes
Features	FEP610 series	FEP630 series
Accuracy	0.5 %	0.4 %, Option up to 0.2 %
Nominal diameter	DN 3 ... 2000 (1/8 ... 80 ")	DN 3 ... 2000 (1/8 ... 80 ")
Liner material	PTFE, Rubber, PFA, ETFE	PTFE, Rubber, PFA, ETFE, Ceramic Carbide Linatex
I/Os	1 × analog, 2 × digital	1 × analog, 2 × digital, option for add-in modules
Communication	High Speed Infrared Port Communication based on HART DTM	HART, Profibus DP, Modbus RTU, Modbus TCP, Ethernet IP
Process diagnostics	Empty pipe	Empty pipe, Partially filling, Gas bubbles, Electrode Impedance, Conductivity, Sensor temperature
Backwards compatibility	–	Yes

... ProcessMaster series

Features and Functions

On-board Health Check

ProcessMaster's in-built fingerprint technology helps to ensure Sensor and Transmitter Integrity without the need to remove the flowmeter from the process. The Check provides a pass / failed result based on a comparison of the current flowmeter status to a set of reference data.

Benefits:

- Easy to operate
- No additional equipment required
- No training necessary
- Quick check of flowmeter integrity

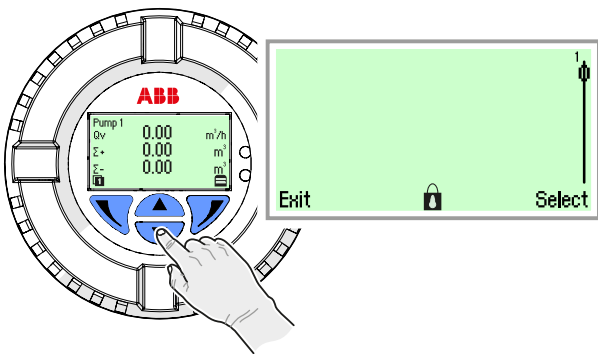

Backwards Compatibility saves your Investment in ABB Flowmetering

Take advantage of new features and improved performance. Switch to the new product at your own timeline. Minimize the cost of change in stock keeping, documentation and change of internal processes.

Benefits:

- Drop in replacement
- Same terminal designation I/O's, sensor connections
- No need to change wiring documentation
- Sensor cable stays unchanged
- Identical operating philosophy:
Easy Set-up and Sensor Set-up
- Common user experience, less training
- Less inventory, less cost

Diagnostics for real-life situations

Detecting critical process conditions at an early stage helps reducing unscheduled downtime and maintenance. Clear text messages simplify troubleshooting. Device diagnostic information can be accessed without any intervention – either through the HMI or bus communication.

Benefits:

- Peace-of-mind that flowmeter is operating within its specification
- Prioritized alarms to correct most important alarm first
- Through-the-glass operation without the need to open the housing

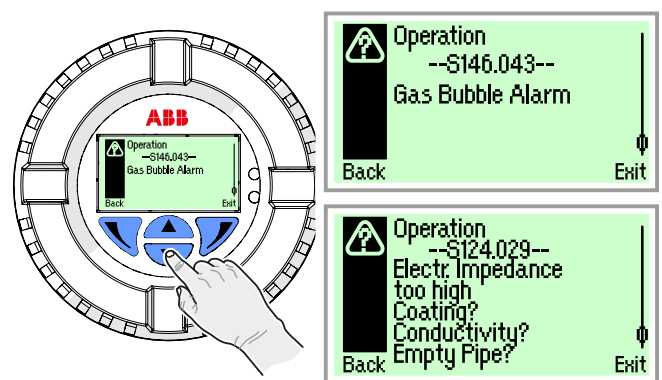

Verify the Installation is correct - from day one

Improving quality and reducing cost can be a challenge if the flow measurement is unstable. A proper grounding is fundamental to an accurate electromagnetic flow measurement. ProcessMaster's in-built noise / grounding check helps getting the wiring / grounding right from day one without the need for further Tools.

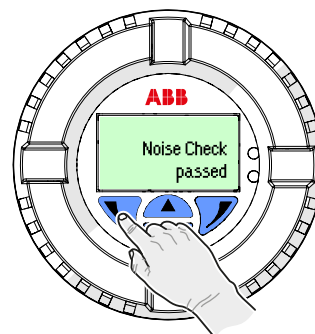

Standard functionality

Flowmeter sensor coil inductance

A measurement of the flowmeter sensor coil inductance can be triggered. This enables to check for the flowmeter sensor coil integrity.

Noise check / Grounding check

This function allows checking for noise and proper electrical grounding of the device. While the check is in progress, no flow measurement can take place.

Pre-requisites using the functionality:

- Flowmeter sensor must be completely filled
- No flow must occur in the flowmeter sensor

Fingerprint

The 'fingerprint' database integrated in the transmitter allows for comparison of the values at the time of factory calibration or commissioning with the currently recorded values.

A quick 'on-board health check' resulting in a pass / fail information can be performed.

For an in-depth verification, an external tool is available from ABB (in preparation).

Detection of partial filling

A partially filled sensor affects the flowmeter reading and the measuring accuracy.

If the flowmeter sensor is ordered with a full pipe detection electrode, which is located at the Top of the sensor, the transmitter's 'Diagnosis TFE' function enables for an alarm in case the sensor tube starts to become partially filled.

Pre-requisites using the functionality:

- Nominal diameter: > DN 50 (> 2")
- Flowmeter sensor design level A
- Conductivity of the measuring medium: 20 ... 20000 $\mu\text{S}/\text{cm}$

Installation conditions:

- The flowmeter sensor must be installed horizontally with the terminal box pointing upward.

Verification

There is an Option for an in-depth verification of the device using an external Tool from ABB.

This Tool provides a brief documentation of the Verification results allowing for a print out.

... ProcessMaster series

Optional diagnostic functions

The extended diagnostics functionality package contains the following functions.

Gasbubble detection

Gas bubbles in the fluid effect the flowmeter reading and the accuracy.

Enhanced diagnostics feature the option for gas bubble detection to make the flow measurement most reliable. There is the option for a gas bubble alarm triggered once the actual gas bubble value exceeds the threshold configured. This alarm is shown in the HMI. The digital output flags an alarm if configured accordingly.

Pre-requisites using the functionality:

- Nominal diameter: DN 10 ... 300 (3/8 ... 12").
- Conductivity of the measuring medium: 20 ... 20000 $\mu\text{S}/\text{cm}$.

Installation conditions:

- The flowmeter sensor can be installed either horizontally or vertically. Vertical installation is preferred.

Conductivity monitoring

The conductivity of the fluid can be monitored setting minimum / maximum alarm limits.

Once alarm limits are exceeded, the digital output flags an alarm if configured accordingly.

Conductivity is available as a 4 ... 20 mA output (Option card).

Pre-requisites using the functionality:

- Conductivity of the measuring medium: 20 ... 20000 $\mu\text{S}/\text{cm}$.

Electrode impedance

An Impedance measurement between the electrode and ground can be triggered.

This enables to check for the electrode integrity.

Flowmeter sensor temperature

A flowmeter sensor temperature measurement can be triggered.

This enables to check for the flowmeter sensor temperature. With flowmeter sensor temperature out of spec, the digital output flags an alarm if configured accordingly.

Transmitter in-house temperature

A in-house temperature measurement can be triggered.

This enables to check for the temperature inside the transmitter housing.

With the temperature out of spec, the digital output flags an alarm if configured accordingly.

Batching function

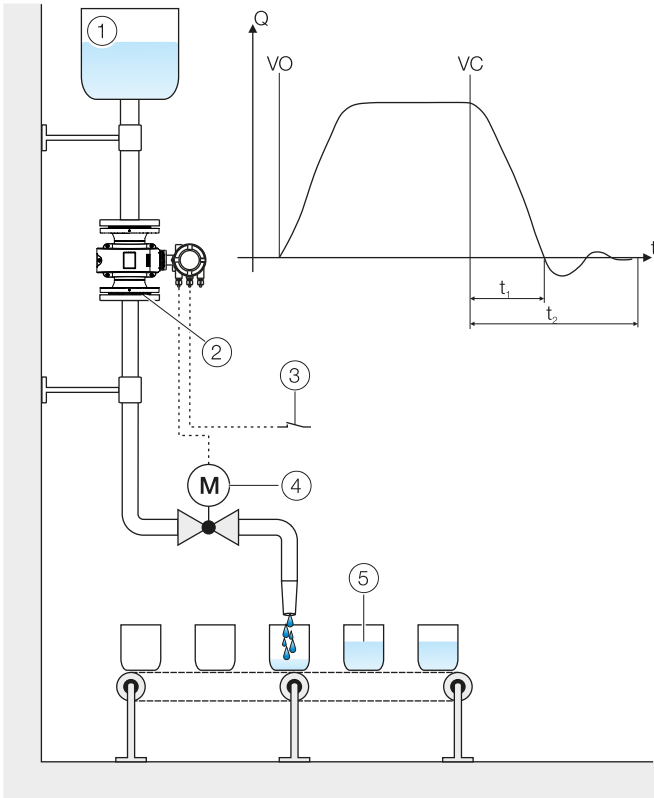

Figure 1 Fill function (batch)

The optional batching functionality allowing for batches with filling times >3 seconds.

Batch quantity is configurable and batch process can be started using the digital input (Option card).

Once batch quantity is reached closing the valve can be triggered using the digital output.

Batch quantity correction is calculated measuring the overrun quantity.

Low flow cut-off can be configured, if required.

Pos.	Description
①	Supply tank
②	Flowmeter sensor
③	Start / stop fill operation (digital input with plug-in card)
④	Filling valve
⑤	Container to be filled
VO	Valve open (filling started)
VC	Valve closed (fill quantity reached)
t_1	Valve closing time
t_2	Overrun time

Table 1 Legend

Overview – models without hazardous area approval

Flowmeter sensor



Figure 2 Designs

Pos.	Description	Pos.	Description
①	Single-compartment transmitter housing	③	Flowmeter sensor, Design Level A (DN 3 ... 2000)
②	Dual-compartment transmitter housing		

Table 2 Legend

Model	ProcessMaster FEP631, FEP632, FET632
Housing	Integral mount design, remote mount design
Measuring accuracy for liquids	0.4 % of measured value, option for 0.3 % and 0.2 % of measured value
Permissible measuring medium temperature T_{medium}	Standard: -25 ... 130 °C (-13 ... 266 °F) Option: -25 ... 180 °C (-13 ... 356 °F)
Minimum conductivity	> 5 $\mu\text{S}/\text{cm}$ (20 $\mu\text{S}/\text{cm}$ for demineralized water)
Nominal pressure rating	PN 6 ... PN 100; ASME CL 150 ... 2500; JIS 5K ... 20K, AS flanges
Nominal diameter	DN 3 ... 2000 (1/10" ... 80")
Process connection	Flange according to DIN, ASME, JIS, AS
Process connection material	Steel, stainless steel
Liner material	Hard rubber (DN 25 ... 2000), soft rubber (DN 50 ... 2000), PTFE (DN 10 ... 600), PFA (DN 3 ... 200), ETFE (DN 25 ... 600), Ceramic Carbide (DN 25 ... 1000), Linatex (DN 50 ... 600)
Electrode material	Stainless steel, Hastelloy B, Hastelloy C, Platinum-Iridium, Tantalum, Titanium, Double layer, Tungsten carbide
IP rating	Integral mount design: IP 65 / IP 67 / NEMA 4X Remote mount design: IP 65 / IP 67 / IP 68 (sensor only) / NEMA 4X

Table 3 Overview flowmeter sensor

Pressure Equipment Directive 2014/68/EU	Conformity assessment in accordance with category III, fluid group 1
CRN (Canadian Reg. Number)	On request
Explosion protection	None
Further approvals	At www.abb.com/flow or on request

Table 4 Approvals

Transmitter

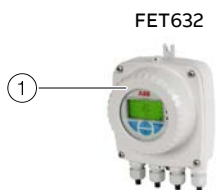

Figure 3 Designs

Pos.	Description
①	Single-compartment transmitter housing

Table 5 Legend

Model	FET632
Housing	Integral mount design, remote mount design.
IP rating	IP 65 / IP 67 / NEMA 4X
Cable length	Maximum 200 m (656 ft), remote mount design only
Power supply	100 ... 240 V AC (-15 / +10 %) 50 / 60 Hz, 16,8 ... 30 V DC
Outputs	Current output: 4 ... 20 mA, active or passive (configurable on site) Digital output 1: passive, configurable as pulse, frequency or switch output Digital output 2: passive, configurable as pulse or switch output
Additional outputs	The transmitter has two slots in the plug-in cards that can be used to extend the outputs. The following plug-in cards are available: <ul style="list-style-type: none"> • Current output (passive) • Digital output (passive) • Digital input (passive) • 24 V DC power supply for active outputs
Communication	Standard: HART 7.1 Option: Profibus DPM, Modbus RTU, Modbus TCP, Ethernet IP

Table 6 Overview Transmitter

Explosion protection	None
Further approvals	At www.abb.com/flow or on request.

Table 7 Approvals Transmitter

Overview – models with Ex protection

Version with integral mount design

The transmitter and the flowmeter sensor form a single mechanical entity.

The transmitter is available in two housing designs

- Single-compartment housing

This is suited for use in ATEX/IEC Ex Zone 2, 22, FM Cl1 Div 2.

In the single-compartment housing, the electronics chamber and the connection chamber in the transmitter are not separated from each other.

- Dual-compartment housing:

This is suited for use in ATEX/IEC Ex Zone 1, 21 und 2, 22, FM Cl1 Div 1.

In the dual-compartment housing, the electronics chamber and the connection chamber in the transmitter are separated from each other.

Note

Further information on the Ex Approval of devices can be found in the type examination certificates or the relevant certificates at www.abb.com/flow.

ATEX / IEC Zone 1, FM Cl1 Div 1

Sensor

ProcessMaster 630
FEP631-F1
Zones 1, 21, Div 1



ATEX

Certificate: FM17ATEX0016X
DN3-2000:
II 2 (1) G Ex db eb ib mb [ia Ga] IIC T6...T1 Gb
II 2 (1) D Ex tb [ia Da] IIIC T80°C...T_{medium} Db

IEC

Certificate: IECEx FME 17.0001X
DN3-2000:
II 2 (1) G Ex db eb ib mb [ia Ga] IIC T6...T1 Gb
II 2 (1) D Ex tb [ia Da] IIIC T80°C...T_{medium} Db

USA, FM approval

Certificate: FM17US0062X
DN3-300:
S-XP-IS: CL I, Div 1, GPS ABCD T6...T1
DIP: CL II,III, Div 1, GPS EFG T6...T3B
>DN300:
CL I, ZN 1, AEx db eb mb [ia Ga] IIC T6...T1 Gb
ZN 21, AEx tb [ia Da] IIIC T80°C...T165°C Db

Canada, FM approval

Certificate: FM17CA0033X
DN3-300:
S-XP-IS: CL I, Div 1, GPS BCD T6...T1
DIP: CL II,III, Div 1, GPS EFG T6...T3B
>DN300:
CL I, ZN 1, Ex db eb mb [ia Ga] IIC T6...T1 Gb
Ex tb [ia Da] IIIC T80°C...T165°C Db

ATEX / IEC Zone 2, FM Cl1 Div 2

Sensor

ProcessMaster 630
FEP631-A2, FEP631-F2
Zone 2, 22, Div 2



ATEX

Certificate: FM17ATEX 0017X
II 3G Ex ec IIC T6...T1 Gc
II 3D Ex tc IIIC T80°C...T_{medium} Dc

IEC

Certificate: IECEx FME 17.0001X
II 3G Ex ec IIC T6...T1 Gc
II 3D Ex tc IIIC T80°C...T_{medium} Dc

USA, FM approval

Certificate: FM17US0062X
NI: CL I, Div 2, GPS ABCD T6...T1
DIP: CL II,III, Div 2, GPS EFG T6...T3B
CL I, ZN 2, AEx ec IIC T6...T1
ZN 21, AEx tb IIIC T80°C...T165°C

Canada, FM approval

Certificate: FM17CA0033X
NI: CL I, Div 2, GPS ABCD T6...T1
DIP: CL II,III, Div 2, GPS EFG T6...T3B
CL I, ZN 2, Ex ec IIC T6...T1 Gc
Ex tb IIIC T80°C...T165°C Db

- 1) Single-compartment housing
2) Dual-compartment housing

Version with remote design

The transmitter is mounted in a separate location from the flowmeter sensor. The electrical connection between the transmitter and flowmeter sensor may only be established using the signal cable supplied. A maximum signal cable length of 200 m (656 ft) is possible.

Note

Further information on the Ex Approval of devices can be found in the type examination certificates or the relevant certificates at www.abb.com/flow.

ATEX / IEC Zone 1, FM Cl1 Div1

The following tables present the combination of the FEP632 sensor in explosion-proof design with the FET632 transmitter.

Sensor

ProcessMaster 630
FEP632-A1, FEP632-F1
in Ex-area, Zone 1, 21, Div 1



ATEX

Certificate: FM17ATEX0016X
DN3-2000: II 2 G Ex eb ib mb IIC T6...T1 Gb
II 2 D Ex tb IIIC T80°C...T_{medium} Db

IEC

Certificate: IECEx FME 17.0001X
DN3-2000: II 2 G Ex eb ib mb IIC T6...T1 Gb
II 2 D Ex tb IIIC T80°C...T_{medium} Db

USA, FM approval

Certificate: FM17US0062X
DN3-300:
S-XP-IS: CL I, Div 1, GPS BCD T6...T1
DIP: CL II,III, Div 1, GPS EFG T6...T3B
>DN300:
CL I, ZN 1, AEx db eb mb [ia Ga] IIB+H2 T6...T1 Gb
ZN 21, AEx tb [ia Da] IIIC T80°C...T165°C Db

Canada, FM approval



Certificate: FM17CA0033X
DN3-300:
S-XP: CL I, Div 1, GPS BCD T6...T1
DIP: CL II,III, Div 1, GPS EFG T6...T3B
>DN300:
CL I, ZN 1, Ex db eb mb IIB+H2 T6...T1 Gb
Ex tb IIIC T80°C...T165°C Db

Overview – models with Ex protection

...Version with remote design

...ATEX / IEC Zone 1, FM Cl1 Div1

The following table presents the combination of the FEP632 sensor in explosion-proof design with the FET632 transmitter.



Transmitter		
FET632-A1, FET632-F1 in Ex-area, Zone 1, 21, Div 1	FET632-A2, FET632-F2 in Ex-area, Zone 2, 22, Div 2	FET632-Y0 Outside Ex-area
 2)	 1)	 1)
ATEX	ATEX	No Ex approval
Certificate: FM17ATEX0016X II 2 (1) G Ex db eb mb [ia Ga] IIC T6 Gb II 2 (1) D Ex tb [ia Da] IIIC T80°C Db	Certificate: FM17ATEX 0017 X II 3G Ex ec IIC T6 Gc II 3D Ex tc IIIC T80°C Dc	
IEC	IEC	
Certificate: IECEX FME 17.0001X II 2 (1) G Ex db eb mb [ia Ga] IIC T6 Gb II 2 (1) D Ex tb [ia Da] IIIC T80°C Db	Certificate: IECEX FME 17.0001 X II 3G Ex ec IIC T6 Gc II 3D Ex tc IIIC T80°C Dc	
USA, FM approval	USA, FM approval	
Certificate: FM17US0062X XP-IS: CL I, Div 1, GPS BCD T6 DIP: CL II,III, Div 1, GPS EFG T6 CL I, ZN 1, AEx db [ia Ga] IIB+H2 T6 Gb ZN 21, AEx tb [ia Da] IIIC T80°C Db	Certificate: FM17US0062X NI: CL I, Div 2, GPS ABCD T6 DIP: CL II,III, Div 2, GPS EFG T6 CL I, ZN 2, AEx ec IIC T6 ZN 21, AEx tb IIIC T80°C	
Canada, FM approval	Canada, FM approval	
Certificate: FM17CA0033X XP-IS: CL I, Div 1, GPS BCD T6 DIP: CL II,III, Div 1, GPS EFG T6 CL I, ZN 1, Ex db [ia Ga] IIB+H2 T6 Gb Ex tb [ia Da] IIIC T80°C Db	Certificate: FM17CA0033X NI: CL I, Div 2, GPS ABCD T6 DIP: CL II,III, Div 2, GPS EFG T6 Ex ec IIC T6 Gc Ex tb IIIC T80°C Db	

1) Single-compartment housing

2) Dual-compartment housing

ATEX / IEC Zone 2, FM Cl1 Div2

The following table presents the combination of the FEP632 sensor in explosion-proof design with the FET632 transmitter.

Sensor	
ProcessMaster 630 FEP632-A2, FEP632-F2 in Ex-area, Zone 2, 22, Div 2	
	
ATEX	
Certificate: FM17ATEX 0017X II 3G Ex ec IIC T6...T1 Gc II 3D Ex tc IIIC T80°C...T _{medium} Dc	
IEC	
Certificate: IECEx FME 17.0001X II 3G Ex ec IIC T6...T1 Gc II 3D Ex tc IIIC T80°C...T _{medium} Dc	
USA, FM approval	
Certificate: FM17US0062X NI: CL I, Div 2, GPS ABCD T6...T1 DIP: CL II,III, Div 2, GPS EFG T6...T6...T3B CL I, ZN 2, AEx ec IIC T6...T1 ZN 21, AEx tb IIIC T80°C...T165°C	
Canada, FM approval	
Certificate: FM17CA0033X NI: CL I, Div 2, GPS ABCD T6...T1 DIP: CL II,III, Div 2, GPS EFG T6...T3B CL I, ZN 2, Ex ec IIC T6...T1 Gc Ex tb IIIC T80°C...T165°C Db	
Transmitter	
FET632-A2, FET632-F2 in Ex-area, Zone 2, 22, Div 2	FET632-Y0 Outside Ex-area
	
ATEX	No Ex approval
Certificate: FM17ATEX 0017 X II 3G Ex ec IIC T6 Gc II 3D Ex tc IIIC T80°C Dc	
IEC	
Certificate: IECEx FME 17.0001 X II 3G Ex ec IIC T6 Gc II 3D Ex tc IIIC T80°C Dc	
USA, FM approval	
Certificate: FM17US0062X NI: CL I, Div 2, GPS ABCD T6 DIP: CL II,III, Div 2, GPS EFG T6 CL I, ZN 2, AEx ec IIC T6 ZN 21, AEx tb IIIC T80°C	
Canada, FM approval	
Certificate: FM17CA0033X Certificate: FM17US0062X NI: CL I, Div 2, GPS ABCD T6 DIP: CL II,III, Div 2, GPS EFG T6 CL I, ZN 2, AEx ec IIC T6 ZN 21, AEx tb IIIC T80°C	

1) Single-compartment housing

Device designs

Overview: The fast track to explosion protection device data

These safety instructions related to explosion protection are valid in conjunction with the following test documentation and certificates:

Scope	Certificate
ATEX Zone 1 / 21	FM17ATEX0016X
ATEX Zone 2 / 22	FM17ATEX 0017X
IEC Ex Zone 1 / 21	IECEX FME 17.0001X
IEC Ex Zone 2 / 22	IECEX FME 17.0001X
FMus Div 1 (USA)	FM17US0062X
FMus Div 2 (USA)	FM17US0062X
cFM Div 1 (Canada)	FM17CA0033X
cFM Div 2 (Canada)	FM17CA0033X
NEPSI Zone 1	GYJ18.1487X
NEPSI Zone 2	GYJ18.1487X

Table 2: Validity range

Model: ProcessMaster 630	Operation in zone	Electrical connection and explosion protection data from chapter
FEP631-A1	Zone1, 21	Operation in Zone 1, 21
FEP631-A2	Zones 2, 22	Operation in Zone 2, 22
FEP632-A1 and FET632-A1	Zone1, 21	Operation in Zone 1, 21
FEP632-A1 and FET632-Y0	Zone1, 21	Operation in Zone 1, 21
FEP632-A2 and FET632-A2	Zones 2, 22	Operation in Zone 2, 22
FEP632-A2 and FET632-Y0	Zones 2, 22	Operation in Zone 2, 22

Table 3: Operational zones

Note

All documentation, declarations of conformity, and certificates are available in ABB's download area: www.abb.com/flow

Measuring principle

Measurements performed by the electromagnetic flowmeter are based on Faraday's law of induction. A voltage is generated in a conductor when it moves through a magnetic field.

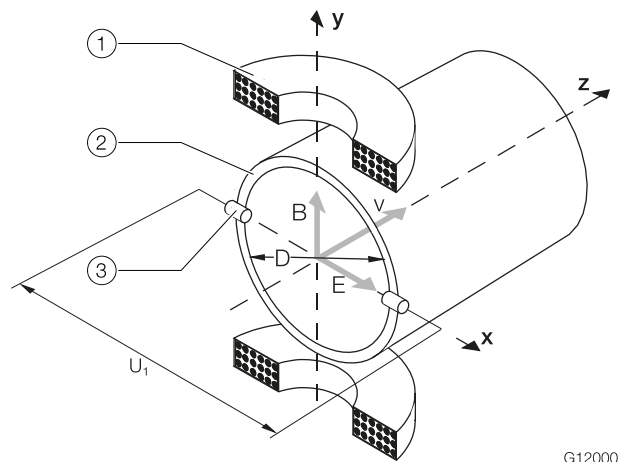

G12000

Figure 4 Electromagnetic flowmeter schematic

Pos.	Description
①	Magnet coil
②	Meter tube in electrode plane
③	Signal electrode

Table 8 Legend

$U_1 \sim B \times D \times v$	$qv = \frac{D^2 \times \pi}{4} \times v$	$U_1 \sim qv$
U_1 – Signal voltage	v – Average flow velocity	
B – Magnetic induction	qv – Volume flow	
D – Electrode spacing		

This principle is applied to a conductive fluid in the meter tube through which a magnetic field is generated perpendicular to the flow direction (see Figure 4). The voltage induced in the fluid is measured by two electrodes located diametrically opposite each other. This signal voltage is proportional to the magnetic induction, the electrode spacing and the average flow velocity. Considering that the magnetic induction and the electrode spacing are constant values, a proportionality exists between the signal voltage U_1 and the average flow velocity. From the equation for calculating the volume flowrate, it follows that the signal voltage is linearly proportional to the volume flowrate.

The induced voltage is converted by the transmitter to standardized, analog and digital signals.

Flowmeter sensor

Measuring accuracy

Reference conditions

According to EN 29104	
Measuring medium temperature	20 °C (68 °F) ±2 K
Ambient temperature	20 °C (68 °F) ±2 K
Power supply	Nominal voltage acc. to name plate U = ±1 %, Frequency f = ±1 %
Installation condition	• Upstream >10 x DN, straight section • Downstream >5 x DN, straight section
Warm-up phase	30 min

Measuring error and repeatability

Measuring error

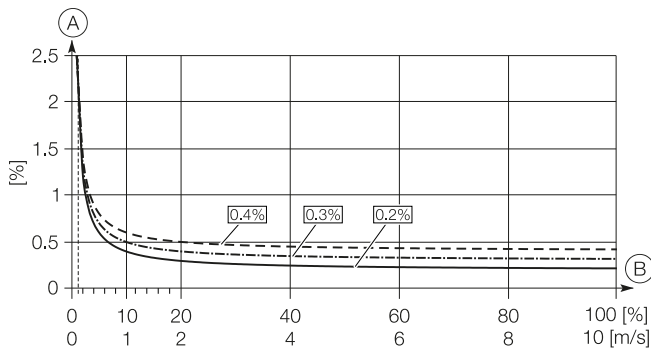

Figure 5 Measuring error

Pos.	Description
(A)	Accuracy ± of measured value in %
(B)	Flow velocity v in m/s, Q / Q _{max} DN in %

Table 9 Legend

Impulse output	
Standard calibration DN 3 2000	
DN 3 2000: ±0.4 % of measured value, ±0.02 % Q _{max} DN ¹⁾	
Optional calibration	
DN 3 600, 800: ±0.3 % of measured value, ±0.02 % Q _{max} DN ¹⁾	
Or	
DN 10 600, 800: ±0.2 % of measured value, ±0.02 % Q _{max} DN ¹⁾	

Table 10 Measuring error impulse output

1) Q_{max} DN: See table in chapter "Measuring range table" on page 20.

Current output	
Same as pulse output plus ±0.1 % of measured value ±0.01 mA	

Table 11 Measuring error current output

Repeatability, response time

Repeatability	Response time ¹⁾
≤ 0.11 % of measured value, t _{meas} = 100 s, v = 0.5 ... 10 m/s	As step function 0 ... 99 % 5 τ ≥ 200 ms at 25 Hz excitation frequency
	5 τ ≥ 400 ms at 12.5 Hz excitation frequency
	5 τ ≥ 500 ms at 6.25 Hz excitation frequency

Table 12 Repeatability, response time

1) Of current output with damping of 0.04 seconds.

Permitted pipe vibration

In accordance with EN 60068-2-6.

Applicable to sensors in remote mount design and sensors in integral mount design.

- Maximum deflection: 0.15 mm (0.006 inch) in the 10 ... 58 Hz range
- Maximum acceleration*: 2 g, in the 58 ... 150 Hz range
- Maximum acceleration: 4g (Tested to DNV DNVGL-CG-0339-2019) for Devices specified with code 'CL5' in Modelcode. CL5 = DNV approved device.

IP rating

- IP 65 / IP 67 in accordance with EN 60529
- IP 68 in accordance with EN 60529 (for remote mount design only)
- NEMA 4X

Signal cables

For remote mount design only.

The maximum signal cable length between flowmeter sensor and transmitter is 200 m (656 ft).

A 5 m (16.4 ft) cable is included in the scope of delivery.

If more than 5 m (16.4 ft) is required, the cable can be ordered separately – see chapter Accessories, page 84.

For marine applications, a certified signal cable is available.

... Flowmeter sensor

Temperature data

Storage temperature range

–40 ... 70 °C (–40 ... 158 °F)

The temperature range offered depends on a number of different factors.

These factors include the measuring medium temperature T_{medium} , the ambient temperature T_{amb} , the operating pressure P_{medium} , the liner material and the approvals for the explosion protection.

Maximum permissible cleaning temperature

CIP medium	Liner material	Cleaning temperature
Steam	PTFE, PFA	150 °C (302 °F)
Cleaning fluid	PTFE, PFA	140 °C (284 °F)

- The specified cleaning temperature applies for a maximum ambient temperature of 25 °C (77 °F). If the ambient temperature is > 25 °C (> 77 °F), the difference to the actual ambient temperature must be subtracted from the maximum cleaning temperature.
- The specified cleaning temperature may be applied for a maximum of 60 minutes.

Ambient temperature as a function of measuring medium temperature
Integral mount design

Note

When using the device in potentially explosive atmospheres, note the additional temperature data in the chapter entitled **Operation in Zone 1,21 / Div 1**, page 60 and chapter **Operation in Zone 2,22 / Div 2**, page 66.

Standard flowmeter sensor design					
Liner material	Flange material	Ambient temperature range (T_{amb.})		Measuring medium temperature range (T_{medium})	
		Minimum	Maximum	Minimum	Maximum
Hard rubber	Steel	-10 °C (14 °F)	60 °C (140 °F)	-10 °C (14 °F)	85 °C (185 °F)
				-5 °C (23 °F) ¹⁾	80 °C (176 °F) ¹⁾
Hard rubber	Stainless steel	-15 °C (5 °F)	60 °C (140 °F)	-15 °C (5 °F)	85 °C (185 °F)
				-5 °C (23 °F) ¹⁾	80 °C (176 °F) ¹⁾
Soft rubber	Steel	-10 °C (14 °F)	60 °C (140 °F)	-10 °C (14 °F)	60 °C (140 °F)
Soft rubber	Stainless steel	-15 °C (5 °F)	60 °C (140 °F)	-15 °C (5 °F)	60 °C (140 °F)
PTFE	Steel	-10 °C (14 °F)	60 °C (140 °F)	-10 °C (14 °F)	90 °C (194 °F)
			45 °C (113 °F)		130 °C (266 °F)
PTFE	Stainless steel	-20 °C (-4 °F)	60 °C (140 °F)	-25 °C (-13 °F)	90 °C (194 °F)
			-40 °C (-40 °F) ²⁾		45 °C (113 °F)
Thick PTFE ³⁾	Steel	-10 °C (14 °F)	60 °C (140 °F)	-10 °C (14 °F)	90 °C (194 °F)
			45 °C (113 °F)		130 °C (266 °F)
Thick PTFE ³⁾	Stainless steel	-20 °C (-4 °F)	60 °C (140 °F)	-25 °C (-13 °F)	90 °C (194 °F)
			-40 °C (-40 °F) ²⁾		45 °C (113 °F)
PFA ³⁾	Steel	-10 °C (14 °F)	60 °C (140 °F)	-10 °C (14 °F)	90 °C (194 °F)
			45 °C (113 °F)		130 °C (266 °F)
PFA ³⁾	Stainless steel	-20 °C (-4 °F)	60 °C (140 °F)	-25 °C (-13 °F)	90 °C (194 °F)
			-40 °C (-40 °F) ²⁾		45 °C (113 °F)
ETFE ³⁾	Steel	-10 °C (14 °F)	60 °C (140 °F)	-10 °C (14 °F)	90 °C (194 °F)
			45 °C (113 °F)		130 °C (266 °F)
ETFE ³⁾	Stainless steel	-20 °C (-4 °F)	60 °C (140 °F)	-25 °C (-13 °F)	90 °C (194 °F)
			-40 °C (-40 °F) ²⁾		45 °C (113 °F)
Linatex ¹⁾	Steel	-10 °C (14 °F)	60 °C (140 °F)	-10 °C (14 °F)	70 °C (158 °F)
Linatex ¹⁾	Stainless steel	-20 °C (-4 °F)	60 °C (140 °F)	-20 °C (-4 °F)	70 °C (158 °F)
Ceramic carbide	Steel	-10 °C (14 °F)	60 °C (140 °F)	-10 °C (14 °F)	80 °C (176 °F)
Ceramic carbide	Stainless steel	-20 °C (-4 °F)	60 °C (140 °F)	-20 °C (-4 °F)	80 °C (176 °F)

... Flowmeter sensor

Note

When using the device in potentially explosive atmospheres, note the additional temperature data in the chapter entitled **Operation in Zone 1,21 / Div 1**, page 60 and chapter **Operation in Zone 2,22 / Div 2**, page 66.

High-temperature flowmeter sensor design ³⁾					
Liner material	Flange material	Ambient temperature range (T _{amb.})		Measuring medium temperature range (T _{medium})	
		Minimum	Maximum	Minimum	Maximum
Thick PTFE ³⁾	Steel	-10 °C (14 °F)	60 °C (140 °F)	-10 °C (14 °F)	180 °C (356 °F)
Thick PTFE ³⁾	Stainless steel	-20 °C (-4 °F) -40 °C (-40 °F) ²⁾	60 °C (140 °F)	-20 °C (-4 °F)	180 °C (356 °F)
PFA ³⁾	Steel	-10 °C (14 °F)	60 °C (140 °F)	-10 °C (14 °F)	180 °C (356 °F)
PFA ³⁾	Stainless steel	-20 °C (-4 °F) -40 °C (-40 °F) ²⁾	60 °C (140 °F)	-20 °C (-4 °F)	180 °C (356 °F)
ETFE ³⁾	Steel	-10 °C (14 °F)	60 °C (140 °F)	-10 °C (14 °F)	130 °C (266 °F)
ETFE ³⁾	Stainless steel	-20 °C (-4 °F) -40 °C (-40 °F) ²⁾	60 °C (140 °F)	-20 °C (-4 °F)	130 °C (266 °F)

1) For China production site only.

2) For low-temperature version only (option).

3) For design level 'A' only.

Remote mount design

Note

When using the device in potentially explosive atmospheres, note the additional temperature data in the chapter entitled **Operation in Zone 1,21 / Div 1**, page 60 and chapter **Operation in Zone 2,22 / Div 2**, page 66.

Standard flowmeter sensor design					
Liner material	Flange material	Ambient temperature range (T_{amb.})		Measuring medium temperature range (T_{medium})	
		Minimum	Maximum	Minimum	Maximum
Hard rubber	Steel	-10 °C (14 °F)	60 °C (140 °F)	-10 °C (14 °F)	85 °C (185 °F)
				-5 °C (23 °F) ¹⁾	80 °C (176 °F) ¹⁾
Hard rubber	Stainless steel	-15 °C (5 °F)	60 °C (140 °F)	-15 °C (5 °F)	85 °C (185 °F)
				-5 °C (23 °F) ¹⁾	80 °C (176 °F) ¹⁾
Soft rubber	Steel	-10 °C (14 °F)	60 °C (140 °F)	-10 °C (14 °F)	60 °C (140 °F)
Soft rubber	Stainless steel	-15 °C (5 °F)	60 °C (140 °F)	-15 °C (5 °F)	60 °C (140 °F)
PTFE	Steel	-10 °C (14 °F)	60 °C (140 °F)	-10 °C (14 °F)	130 °C (266 °F)
			45 °C (113 °F)	130 °C (266 °F)	
PTFE	Stainless steel	-25 °C (-13 °F)	60 °C (140 °F)	-25 °C (-13 °F)	130 °C (266 °F)
		-40 °C (-40 °F) ²⁾			
Thick PTFE ³⁾	Steel	-10 °C (14 °F)	60 °C (140 °F)	-10 °C (14 °F)	130 °C (266 °F)
Thick PTFE ³⁾	Stainless steel	-25 °C (-13 °F)	60 °C (140 °F)	-25 °C (-13 °F)	130 °C (266 °F)
		-40 °C (-40 °F) ²⁾			
PFA ³⁾	Steel	-10 °C (14 °F)	60 °C (140 °F)	-10 °C (14 °F)	130 °C (266 °F)
PFA ³⁾	Stainless steel	-25 °C (-13 °F)	60 °C (140 °F)	-25 °C (-13 °F)	130 °C (266 °F)
		-40 °C (-40 °F) ²⁾			
ETFE ³⁾	Steel	-10 °C (14 °F)	60 °C (140 °F)	-10 °C (14 °F)	130 °C (266 °F)
ETFE ³⁾	Stainless steel	-25 °C (-13 °F)	60 °C (140 °F)	-25 °C (-13 °F)	130 °C (266 °F)
Linatex ¹⁾	Steel	-10 °C (14 °F)	60 °C (140 °F)	-10 °C (14 °F)	70 °C (158 °F)
Linatex ¹⁾	Stainless steel	-20 °C (-4 °F)	60 °C (140 °F)	-20 °C (-4 °F)	70 °C (158 °F)
Ceramic carbide	Steel	-10 °C (14 °F)	60 °C (140 °F)	-10 °C (14 °F)	80 °C (176 °F)
Ceramic carbide	Stainless steel	-25 °C (-13 °F)	60 °C (140 °F)	-20 °C (-4 °F)	80 °C (176 °F)

Note

When using the device in potentially explosive atmospheres, note the additional temperature data in the chapter entitled **Operation in Zone 1,21 / Div 1**, page 60 and chapter **Operation in Zone 2,22 / Div 2**, page 66.

High-temperature flowmeter sensor design³⁾					
Liner material	Flange material	Ambient temperature range (T_{amb.})		Measuring medium temperature range (T_{medium})	
		Minimum	Maximum	Minimum	Maximum
Thick PTFE ³⁾	Steel	-10 °C (14 °F)	60 °C (140 °F)	-10 °C (14 °F)	180 °C (356 °F)
Thick PTFE ³⁾	Stainless steel	-25 °C (-13 °F)	60 °C (140 °F)	-25 °C (-13 °F)	180 °C (356 °F)
		-40 °C (-40 °F) ²⁾			
PFA ³⁾	Steel	-10 °C (14 °F)	60 °C (140 °F)	-10 °C (14 °F)	180 °C (356 °F)
PFA ³⁾	Stainless steel	-25 °C (-13 °F)	60 °C (140 °F)	-25 °C (-13 °F)	180 °C (356 °F)
		-40 °C (-40 °F) ²⁾			
ETFE ³⁾	Steel	-10 °C (14 °F)	60 °C (140 °F)	-10 °C (14 °F)	130 °C (266 °F)
ETFE ³⁾	Stainless steel	-25 °C (-13 °F)	60 °C (140 °F)	-25 °C (-13 °F)	130 °C (266 °F)
		-40 °C (-40 °F) ²⁾			

1) For China production site only.
 2) For low-temperature version only (option).
 3) For design level 'A' only.

... Flowmeter sensor

Measuring range table

The flow range end value can be set between $0.02 \times Q_{\max \text{ DN}}$ and $2 \times Q_{\max \text{ DN}}$.

Nominal diameter		Minimum flow range end value	QmaxDN	Maximum flow range end value
DN	inch	$0.02 \times Q_{\max \text{ DN}} (\approx 0.2 \text{ m/s})$	$0 \dots \approx 10 \text{ m/s}$	$2 \times Q_{\max \text{ DN}} (\approx 20 \text{ m/s})$
3	1/10	0.08 l/min (0.02 US gal/min)	4 l/min (1.06 US gal/min)	8 l/min (2.11 US gal/min)
4	5/32	0.16 l/min (0.04 US gal/min)	8 l/min (2.11 US gal/min)	16 l/min (4.23 US gal/min)
6	1/4	0.4 l/min (0.11 US gal/min)	20 l/min (5.28 US gal/min)	40 l/min (10.57 US gal/min)
8	5/16	0.6 l/min (0.16 US gal/min)	30 l/min (7.93 US gal/min)	60 l/min (15.85 US gal/min)
10	3/8	0.9 l/min (0.24 US gal/min)	45 l/min (11.9 US gal/min)	90 l/min (23.78 US gal/min)
15	1/2	2 l/min (0.53 US gal/min)	100 l/min (26.4 US gal/min)	200 l/min (52.8 US gal/min)
20	3/4	3 l/min (0.79 US gal/min)	150 l/min (39.6 US gal/min)	300 l/min (79.3 US gal/min)
25	1	4 l/min (1.06 US gal/min)	200 l/min (52.8 US gal/min)	400 l/min (106 US gal/min)
32	1 1/4	8 l/min (2.11 US gal/min)	400 l/min (106 US gal/min)	800 l/min (211 US gal/min)
40	1 1/2	12 l/min (3.17 US gal/min)	600 l/min (159 US gal/min)	1200 l/min (317 US gal/min)
50	2	1.2 m ³ /h (5.28 US gal/min)	60 m ³ /h (264 US gal/min)	120 m ³ /h (528 US gal/min)
65	2 1/2	2.4 m ³ /h (10.57 US gal/min)	120 m ³ /h (528 US gal/min)	240 m ³ /h (1057 US gal/min)
80	3	3.6 m ³ /h (15.9 US gal/min)	180 m ³ /h (793 US gal/min)	360 m ³ /h (1585 US gal/min)
100	4	4.8 m ³ /h (21.1 US gal/min)	240 m ³ /h (1057 US gal/min)	480 m ³ /h (2113 US gal/min)
125	5	8.4 m ³ /h (37 US gal/min)	420 m ³ /h (1849 US gal/min)	840 m ³ /h (3698 US gal/min)
150	6	12 m ³ /h (52.8 US gal/min)	600 m ³ /h (2642 US gal/min)	1200 m ³ /h (5283 US gal/min)
200	8	21.6 m ³ /h (95.1 US gal/min)	1080 m ³ /h (4755 US gal/min)	2160 m ³ /h (9510 US gal/min)
250	10	36 m ³ /h (159 US gal/min)	1800 m ³ /h (7925 US gal/min)	3600 m ³ /h (15850 US gal/min)
300	12	48 m ³ /h (211 US gal/min)	2400 m ³ /h (10567 US gal/min)	4800 m ³ /h (21134 US gal/min)
350	14	66 m ³ /h (291 US gal/min)	3300 m ³ /h (14529 US gal/min)	6600 m ³ /h (29059 US gal/min)
400	16	90 m ³ /h (396 US gal/min)	4500 m ³ /h (19813 US gal/min)	9000 m ³ /h (39626 US gal/min)
450	18	120 m ³ /h (528 US gal/min)	6000 m ³ /h (26417 US gal/min)	12000 m ³ /h (52834 US gal/min)
500	20	132 m ³ /h (581 US gal/min)	6600 m ³ /h (29059 US gal/min)	13200 m ³ /h (58117 US gal/min)
600	24	192 m ³ /h (845 US gal/min)	9600 m ³ /h (42268 US gal/min)	19200 m ³ /h (84535 US gal/min)
700	28	264 m ³ /h (1162 US gal/min)	13200 m ³ /h (58118 US gal/min)	26400 m ³ /h (116236 US gal/min)
750	30	312 m ³ /h (1374 US gal/min)	15600 m ³ /h (68685 US gal/min)	31200 m ³ /h (137369 US gal/min)
760	30	312 m ³ /h (1374 US gal/min)	15600 m ³ /h (68685 US gal/min)	31200 m ³ /h (137369 US gal/min)
800	32	360 m ³ /h (1585 US gal/min)	18000 m ³ /h (79252 US gal/min)	36000 m ³ /h (158503 US gal/min)
900	36	480 m ³ /h (2113 US gal/min)	24000 m ³ /h (105669 US gal/min)	48000 m ³ /h (211337 US gal/min)
1000	40	540 m ³ /h (2378 US gal/min)	27000 m ³ /h (118877 US gal/min)	54000 m ³ /h (237754 US gal/min)
1050	42	616 m ³ /h (2712 US gal/min)	30800 m ³ /h (135608 US gal/min)	61600 m ³ /h (271217 US gal/min)
1100	44	660 m ³ /h (3038 US gal/min)	33000 m ³ /h (151899 US gal/min)	66000 m ³ /h (290589 US gal/min)
1200	48	840 m ³ /h (3698 US gal/min)	42000 m ³ /h (184920 US gal/min)	84000 m ³ /h (369841 US gal/min)
1400	54	1080 m ³ /h (4755 US gal/min)	54000 m ³ /h (237755 US gal/min)	108000 m ³ /h (475510 US gal/min)
1500	60	1260 m ³ /h (5548 US gal/min)	63000 m ³ /h (277381 US gal/min)	126000 m ³ /h (554761 US gal/min)
1600	66	1440 m ³ /h (6340 US gal/min)	72000 m ³ /h (317006 US gal/min)	144000 m ³ /h (634013 US gal/min)
1800	72	1800 m ³ /h (7925 US gal/min)	90000 m ³ /h (396258 US gal/min)	180000 m ³ /h (792516 US gal/min)
2000	80	2280 m ³ /h (10039 US gal/min)	114000 m ³ /h (501927 US gal/min)	228000 m ³ /h (1003853 US gal/min)

Process connections

For an overview of the available process connection variants, see the chapter entitled "Overview – models without hazardous area approval" on page 8.

Installation length

The flange devices comply with the installation lengths specified in ISO 13359.

For further details, refer to chapter "Dimensions" on page 30.

Materials

Wetted parts

Part	Standard	Option
Liner material	PTFE, PFA, ETFE, hard rubber, soft rubber	Ceramic Carbide, Linatex

Measurement and grounding electrode for liner material

• Hard rubber	SST 1.4571 (AISI 316Ti)	Hastelloy B-3 (2.4600), Hastelloy C-4 (2.4610), titanium, Tantalum, Platinum-iridium, SST 1.4539 (AISI 904L)
• Soft rubber		
• PTFE, PFA, ETFE	SST 1.4539 (AISI 904L)	SST 1.4571 (AISI 316Ti), Hastelloy B-3 (2.4600), Hastelloy C-4 (2.4610), Titanium, Tantalum, Platinum-iridium

Grounding ring	Stainless steel	On request
Protection plate	Stainless steel	On request

Non-wetted parts (process connection), Design level 'A'



DN	Standard	Option
DN 3 ... 15 (1/10 ... 1/2")	Stainless steel ¹⁾	–
DN 20 ... 400 (3/4 ... 16")	Steel (galvanized) ²⁾	Stainless steel ¹⁾
DN 450 ... 2000 (18 ... 80")	Steel (painted) ²⁾	–

The process connections are made of one of the materials listed below:

- 1) 1.4301 (AISI 304), 1.4307, 1.4404 (AISI 316L) 1.4435 (AISI 316L), 1.4541 (AISI 321) 1.4571 (AISI 316Ti)
- 2) 1.0038, 1.0460, 1.0570, 1.0432, ASTM A105, Q255A, 20#, 16Mn

... Flowmeter sensor

Sensor housing, Design level 'A'



Part / DN	Material
Housing	
DN 3 ... 400 (1/10 ... 16")	Cast aluminum (painted) Paint coat: $\geq 80 \mu\text{m}$ thick, RAL 9002
DN 450 ... 2000 (18 ... 80")	Welded steel design (painted) Paint coat: $\geq 80 \mu\text{m}$ thick, RAL 9002
Meter tube	Stainless steel ⁴⁾
Terminal box	Aluminum alloy, painted, $\geq 80 \mu\text{m}$ thick, light gray, RAL 9002 Option: Plastic, gray white, RAL 9002 Option: Stainless Steel
Cable gland⁵⁾	Polyamide, stainless Steel ⁶⁾

The meter tube is made of one of the materials listed below:

4) 1.4301, 1.4307, 1.4404, 1.4435, 1.4541, 1.4571

ASTM materials:

Grade TP304, TP304L, TP316L, TP321, TP316Ti, TP317L, 0Cr18Ni9, 00Cr18Ni10, 0Cr17Ni14Mo2, 0Cr27Ni12Mo3, 0Cr18Ni10Ti

5) Cable gland with M 20 x 1.5 or NPT thread, to be selected via the order number.

6) In the case of explosion-proof design or for ambient temperature of 40 °C (40 °F).

Material loads for process connections

The limits for the permissible measuring medium temperature (T_{medium}) and permissible pressure (P_{medium}) are calculated on the basis of the lining and flange material used in the device (refer to the name plate on the device).

Minimum permissible operating pressure

The following tables show the minimum permissible operating pressure (P_{medium}) depending on measuring medium temperature (T_{medium}) and the liner material.

Design level 'A'



Liner material	Nominal diameter	P_{medium} [mbar abs]	T_{medium} ¹⁾
Hard rubber	DN 25 ... 2000 (1 ... 80")	0	< 85 °C (185 °F)
			< 80 °C (176 °F) ²⁾
Soft rubber	DN 50 ... 2000 (2 ... 80")	0	< 60 °C (140 °F)
PTFE	DN 10 ... 600 (3/8 ... 24")	270	< 20 °C (68 °F)
		400	< 100 °C (212 °F)
		500	< 130 °C (266 °F)
Thick PTFE	DN 25 ... 80 (1 ... 3")	0	< 180 °C (356 °F)
	DN 100 ... 250 (4 ... 10")	67	< 180 °C (356 °F)
	DN 300 (12")	27	< 180 °C (356 °F)
PFA	DN 3 ... 200 (1/10 ... 8")	0	< 180 °C (356 °F)
ETFE	DN 25 ... 600 (1 ... 24")	100	< 130 °C (266 °F)
Ceramic Carbide	DN 25 ... 1000 (1 ... 40")	0	< 80 °C (176 °F)
Linatex ²⁾	DN 50 ... 600 (6 ... 24")	0	< 70 °C (158 °F)

1) For CIP/SIP cleaning, higher temperatures are permitted for limited time periods; refer to the chapter "Maximum permissible cleaning temperature" on page 16.

2) For China production site only.

Material load

Flowmeter sensor design level 'A'

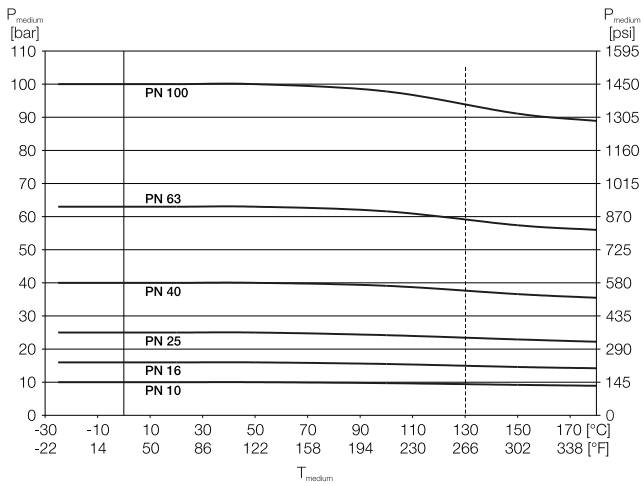

Figure 6 DIN flange stainless steel up to DN 600 (24"); design level 'A'

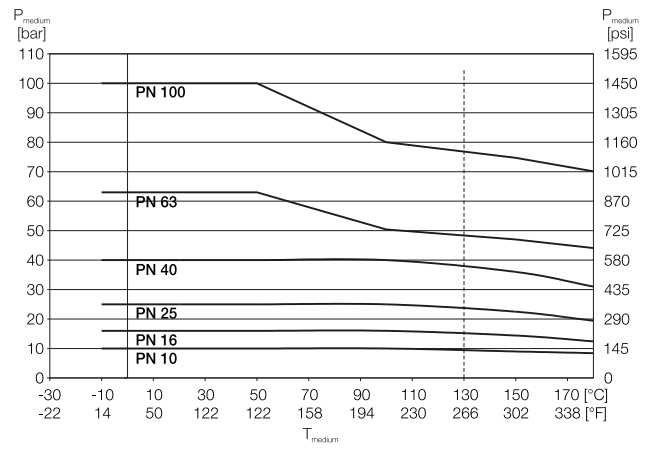

Figure 8 DIN flange, steel, up to DN 600 (24"); design level 'A'

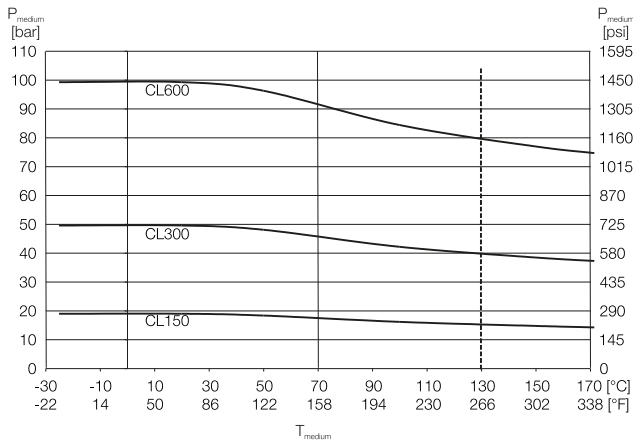

Figure 7 ASME flange, stainless steel, up to DN 400 (16") (CL150/300) up to DN 1000 (40") (CL150); design level 'A'

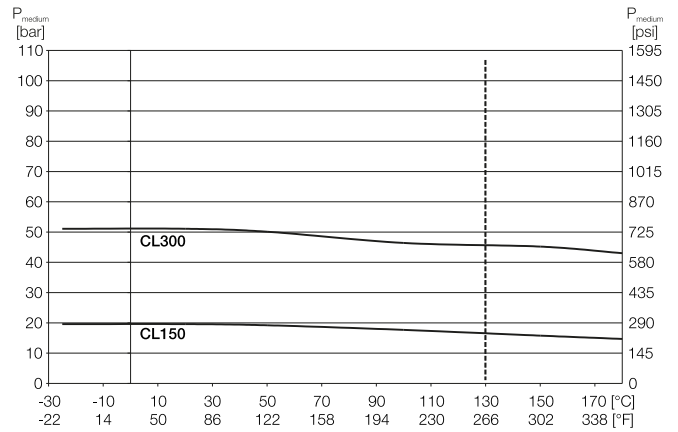

Figure 9 ASME flange, steel, up to DN 400 (16") (CL150/300); up to DN 1000 (40") (CL150); design level 'A'

DN	Material	PN	T _{medium}	P _{medium}
DN 32 ... 400 (1 1/4 ... 16")	Stainless steel	10	-25 ... 180 °C (-13 ... 356 °F)	10 bar (145 psi)
DN 32 ... 400 (1 1/4 ... 16")	Steel	10	-10 ... 180 °C (14 ... 356 °F)	10 bar (145 psi)

Table 13 Material load JIS 10K-B2210 flange

... Flowmeter sensor

...Material load

...Flowmeter sensor design level 'A'

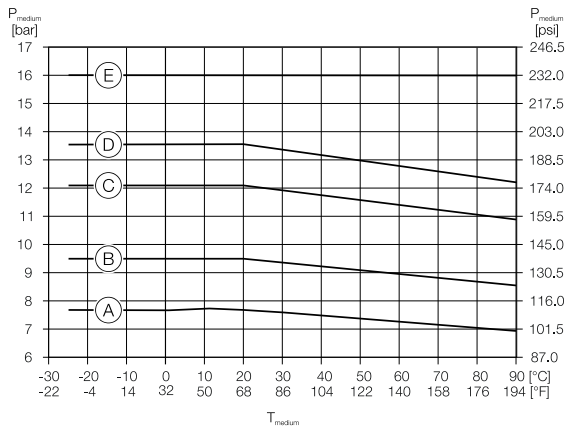

Figure 10 DIN flange, stainless steel, DN 700 (28") up to DN 1000 (40"); design level 'A'

Pos.	Nominal diameter / Pressure rating flowmeter sensor
(A)	DN 1000, PN 10
(B)	DN 700, DN800, DN900, PN 10
(C)	DN 1000, PN 16
(D)	DN 900, DN 800, PN 16
(E)	DN 700, PN 16

Table 14 Legend

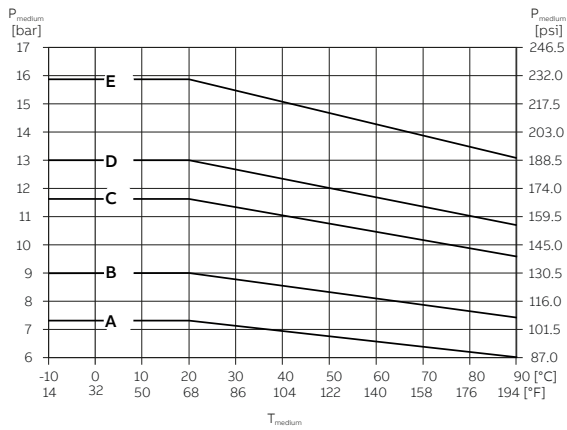

Figure 11 DIN flange, steel, DN 700 (28") up to DN 1000 (40"); design level 'A'

Pos.	Nominal diameter / Pressure rating flowmeter sensor
(A)	DN 1000, PN 10
(B)	DN 700, DN800, DN900, PN 10
(C)	DN 1000, PN 16
(D)	DN 900, DN 800, PN 16
(E)	DN 700, PN 16

Table 15 Legend

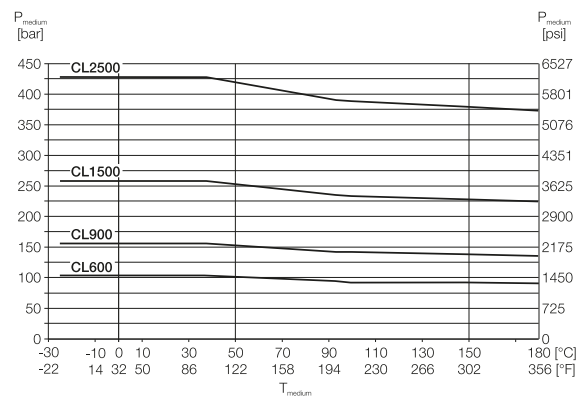

Figure 12 ASME flange, steel, DN 25 ... 400 (1 ... 24"); design level 'A'

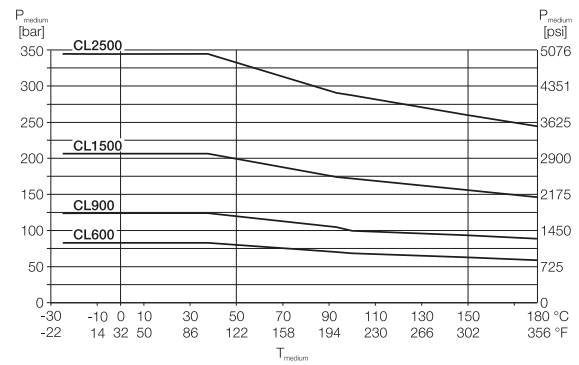

Figure 13 ASME flange, stainless steel, DN 25 ... 400 (1 ... 24"); design level 'A'

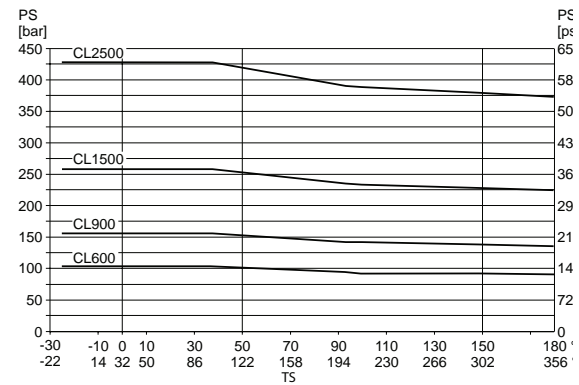

Figure 14 ASME flange, Steel, DN 25 ... 400 (1 ... 24")

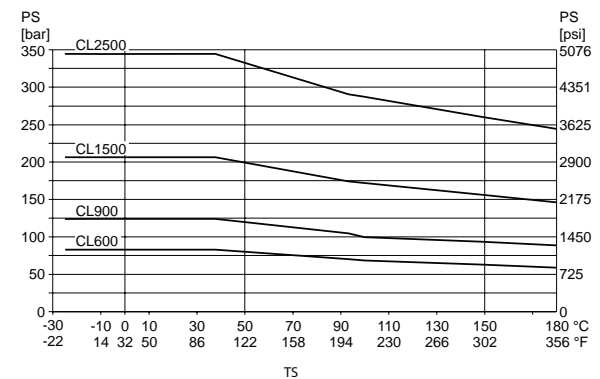

Figure 15 ASME flange, stainless steel, DN 25 ... 400 (1 ... 24")

Installation conditions

General information

The following points must be observed during installation:

- The flow direction must correspond to the marking, if present.
- The maximum torque for all flange screws must be complied with.
- Secure the flange screws and nuts against pipe vibration.
- The devices must be installed without mechanical tension (torsion, bending).
- Install flange devices / wafer-type devices with plane parallel counterflanges and use appropriate gaskets only.
- Only gaskets made from a material that is compatible with the measuring medium and measuring medium temperature may be used.
- Gaskets must not extend into the flow area, since possible turbulence could influence the accuracy of the device.
- The piping may not exert any inadmissible forces or torques on the device.
- Make sure temperature limits are not exceeded operating the device.
- Vacuum shocks in the piping should be avoided to prevent damage to the liners (PTFE). Vacuum shocks can destroy the device.
- Do not remove the sealing plugs in the cable glands until you are ready to install the electrical cable.
- Make sure the gaskets for the housing cover are seated correctly. Carefully gasket the cover. Tighten the cover fittings.
- The transmitter with a remote mount design must be installed at a largely vibration-free location.
- Do not expose the transmitter and sensor to direct sunlight. Provide appropriate sun protection as necessary.
- When installing the transmitter in a control cabinet, make sure adequate cooling is provided.

Devices with extended diagnostic functions

For devices with extended diagnostic functions different installation conditions may be valid.

For further information refer to **Standard functionality** on page 5.

... Flowmeter sensor

Brackets and supports

NOTICE – Potential damage to device!

Improper support for the device may result in deformed housing and damage to internal magnet coils. Place the supports at the edge of the flowmeter sensor housing (see arrows in Figure 16).

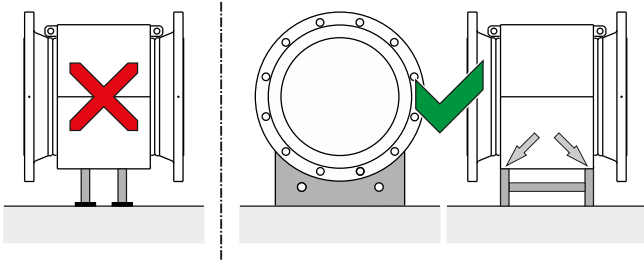

Figure 16 Support for meter sizes larger than DN 400

Devices with meter sizes larger than DN 400 must be mounted with support on a sufficiently strong foundation.

Gaskets

The following points must be observed when installing gaskets:

- For achieve the best results, ensure the gaskets fit concentrically with the meter tube
- To ensure that the flow profile is not distorted, the gaskets must not protrude into the piping.
- The use of graphite with the flange or process connection gaskets is prohibited, because an electrically conductive coating may form on the inside of the meter tube.
- For Non RTJ flange type sensors used in high pressure installations (PN63, CL600 and up), ensure using an appropriate gasket.

Devices with a hard rubber, soft rubber liner

- Devices with a hard / soft rubber liner always require additional gaskets.
- ABB recommends using gaskets made from rubber or rubber-like sealing materials.
- When selecting the gaskets, ensure that the tightening torques specified in chapter are not exceeded.

Devices with a PTFE, PFA or ETFE liner

- Devices with a PTFE, PFA or ETFE liner do not require additional gaskets.

Flow direction

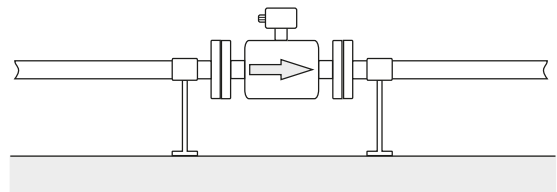

Figure 17 Flow direction

The device measures the flowrate in both directions. Forward flow is the factory setting, as shown in Figure 17.

Elektrode axis

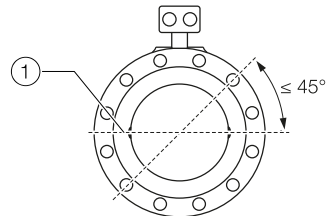

Figure 18 Orientation of the electrode axis

The electrode axis ① should be horizontal if at all possible or no more than 45° from horizontal.

Mounting position

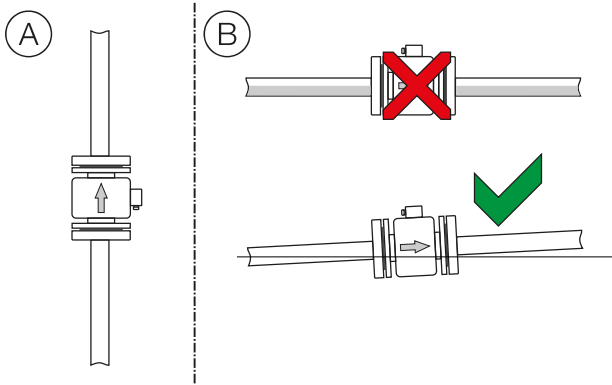

Figure 19 Mounting position

- Ⓐ Vertical installation for measuring abrasive fluids, preferably with flow in upward direction.
- Ⓑ In case of horizontal installation, the Meter tube must always be completely full. Provide for a slight incline of the connection for degassing.

Minimum distance

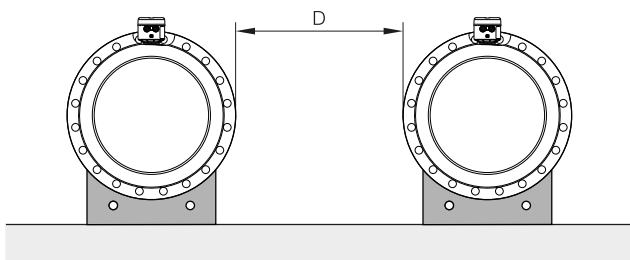

Figure 20 Minimum distance

Distance D: ≥ 1.0 m (3.3 ft) for design level 'A', ≥ 0.7 m (2.3 ft) for design level 'B'

- In order to prevent the devices from interfering with each other, a minimum distance as shown in Figure 20 must be maintained between the devices.
- The flowmeter sensor may not be operated in the vicinity of powerful electromagnetic fields, e.g., motors, pumps, transformers, etc. A minimum spacing of approx. 1 m (3.28 ft) should be maintained.
- For installation on or to steel parts (e.g. steel brackets), a minimum spacing of approx. 100 mm (3.94 inch) should be maintained (based on IEC801-2 and IECTC77B).

Inlet and outlet sections

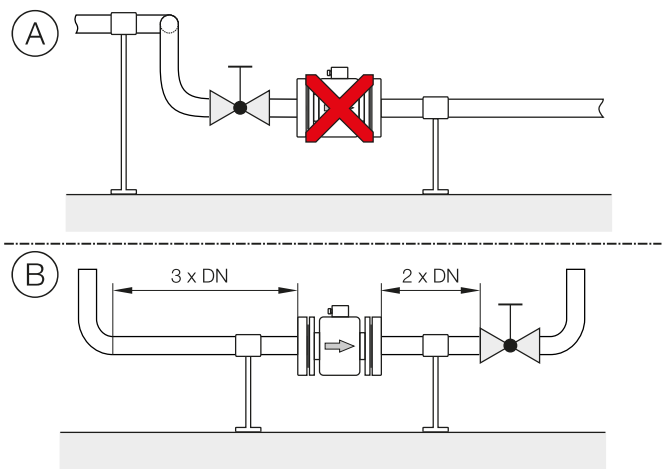

Figure 21 In- and outlet section, turn-off component

Pos.	Description
①	Double elbow
②	Turn-off device

Table 16: Legend

The metering principle is independent of the flow profile as long as standing eddies do not extend into the metering section, such as may occur after double elbows, in the event of tangential inflow, or where half-open gate valves are located upstream of the flowmeter sensor. In such cases, measures must be put in place to normalize the flow profile.

- Ⓐ Do not install fittings, manifolds, valves, etc., directly in front of the flowmeter sensor.
- Ⓑ Inlet and outlet section: Length of straight inlet and outlet section of the flowmeter sensor. Experience has shown that, in most installations, inlet sections 3 x DN long and outlet sections 2 x DN long are sufficient (DN = nominal diameter of the flowmeter sensor). For test stands, the reference conditions of 10 x DN inlet section and 5 x DN outlet section must be provided, in accordance with EN 29104 / ISO 9104. Valves or other turn-off components should be installed in the outlet section. Butterfly valves must be installed so that the valve plate does not extend into the flowmeter sensor.

... Flowmeter sensor

Free inlet or outlet

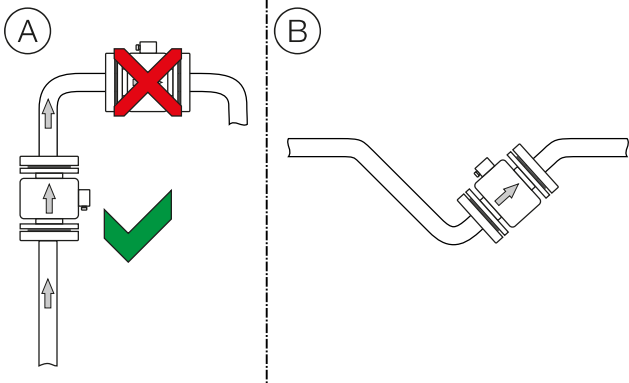

Figure 22 Free inlet or outlet

- (A) Do not install the flowmeter at the highest point or in the draining off side of the pipeline, flowmeter runs empty, air bubbles can form.
- (B) Provide for a siphon fluid intake for free inlets or outlets so that the pipeline is always full.

Strongly contaminated measuring media

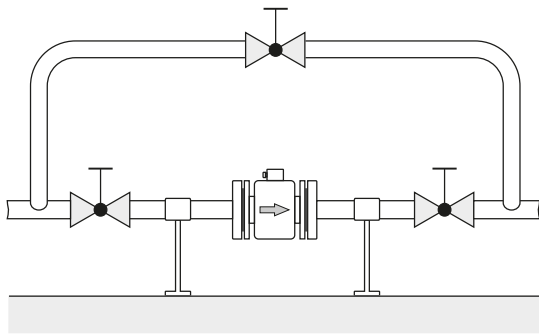

Figure 23 Bypass connection

For strongly contaminated measuring media, a bypass connection according to the figure is recommended so that operation of the system can continue to run without interruption during the mechanical cleaning.

Sensor insulation

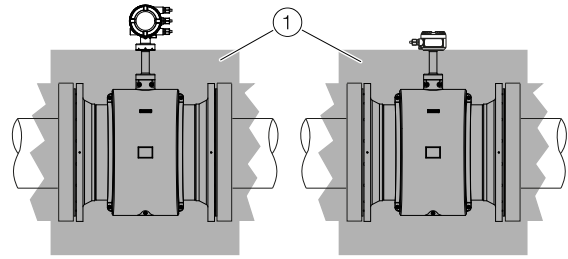

Figure 24 Insulation of the flowmeter sensor

The high temperature design allows for complete thermal insulation of the flowmeter sensor. The pipeline and sensor must be insulated ① after installing the unit according to the illustration.

Grounding

The flowmeter sensor must be connected to ground potential. For technical reasons, this potential should be identical to the potential of the measuring medium. For plastic or insulated lined pipelines, the measuring medium is grounded by installing ground plates. When there are stray potentials present in the pipeline, a ground plate is recommended on both ends of the flowmeter sensor.

Installation in the vicinity of pumps

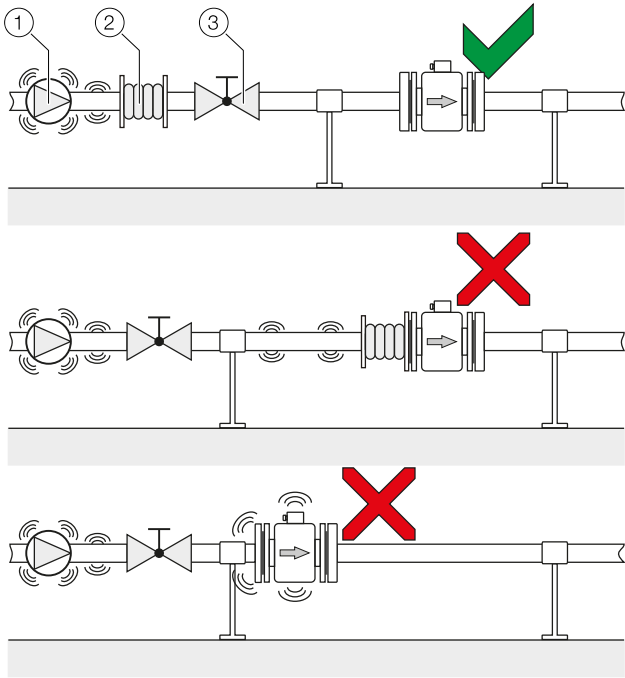

Figure 25 Vibration damping

Pos.	Description
①	Pump
②	Damping device
③	Shut-off device

Table 17: Legend

Strong vibrations in the pipeline must be damped using flexible damping devices.

The damping devices must be installed beyond the supported flowmeter section and outside of the section between the shut-off devices.

Do not connect flexible damping devices directly to the flowmeter sensor.

Installation in pipelines with larger nominal diameters

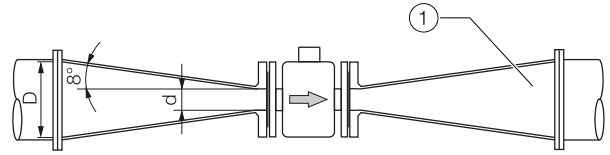

Figure 26 Using reduction pieces

Determine the resulting pressure loss when using transition pieces ①:

1. Calculate the diameter ratio d/D .
2. Determine the flow velocity based on the flow rate nomogram (Figure 27).
3. Read the pressure drop on the Y-axis in Figure 27.

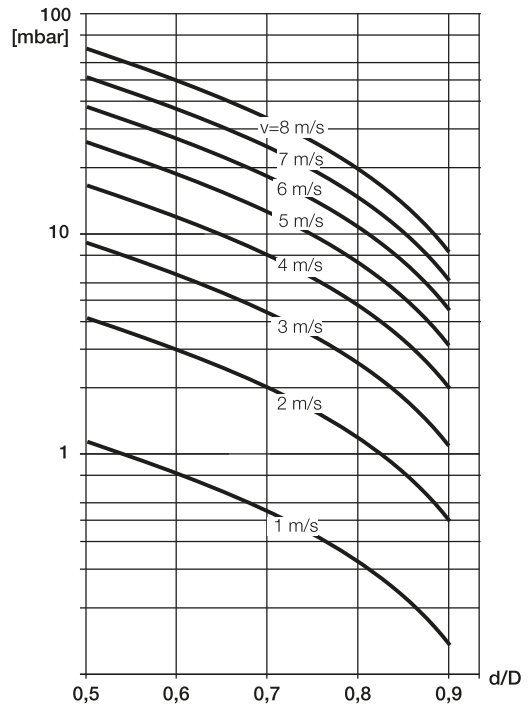

Figure 27 Flow rate nomogram for pressure drop calculations for flange transition piece with $\alpha/2 = 8^\circ$

High pressure sensors (PN63, CI600 and up)

With sensors, designed for higher pressure rating, the inner diameter of the sensor might be different from the attached pipe – see dimensions table.

... Flowmeter sensor

Dimensions

Flange DN 3 ... 100 (1/10 ... 4"), aluminum sensor housing (shell housing) – Design level 'A'

All specified dimensions and weights are in mm (inch) or kg (lb). The stated weights are approximate; the maximum weight is always stated.

Integral mount design

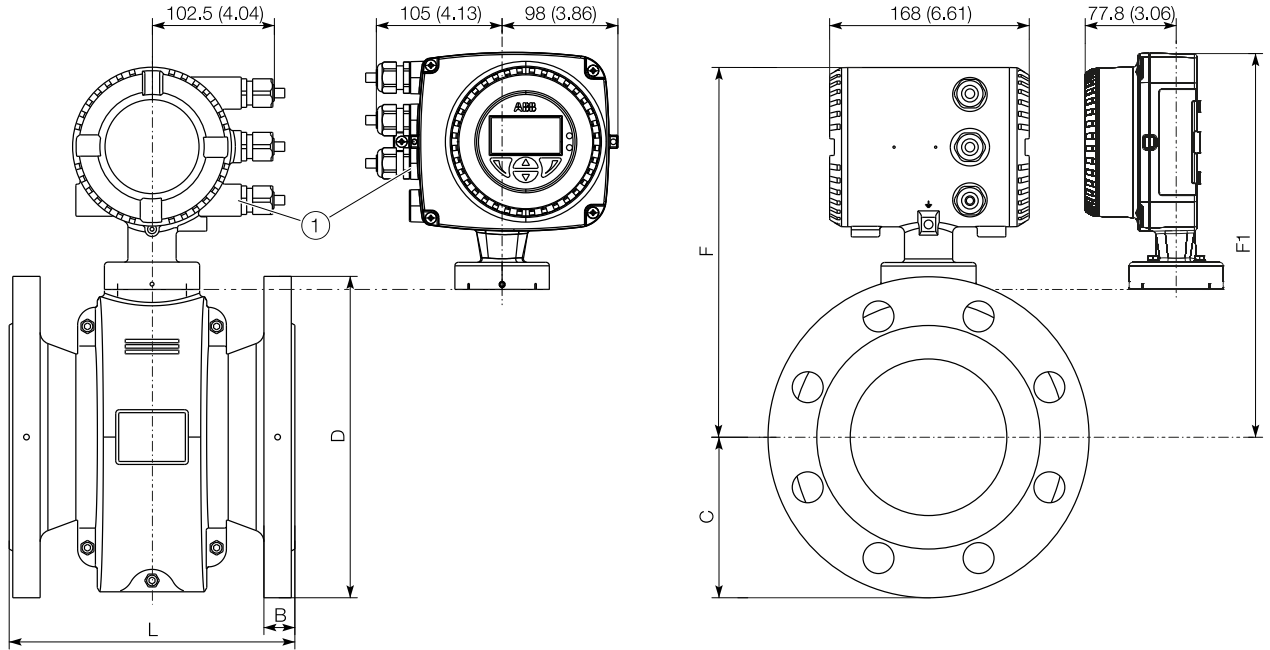

Remote mount design

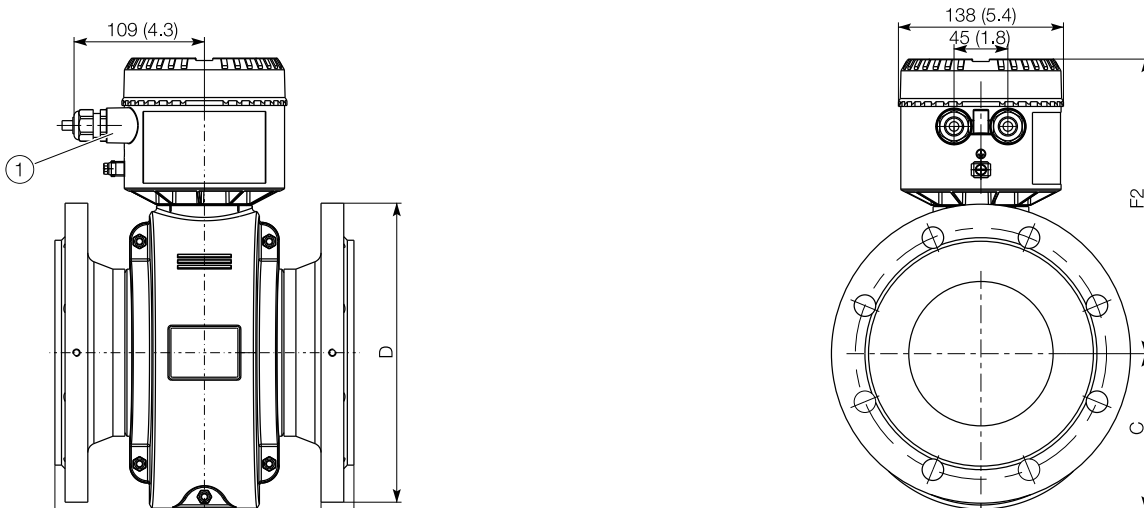

① Female thread (either 1/2" NPT or M20 x 1,5) refer to model coding. With 1/2" NPT there will be a plug instead of the PG cable inlet.

Figure 28 Integral mount design (top), remote mount design (bottom)

Dimensions – Flange device, aluminum sensor housing (shell housing) — Design level 'A'									
Nominal diameter	Process connection	D	B	L⁽²⁾³⁾	C	F^(7,8)	F1^(7,8)	F2^(7,8)	Weight
DN 3 ... 8 ⁽⁴⁾ (1/8 ... 5/16 ⁽⁵⁾)	EN 1092-1 ⁽⁶⁾ , PN 10 ... 40 ⁽¹⁾	90 (3.54)	19 (0.75)	200 (7.84)	82 (3.23)	255 (10.04)	269 (10.6)	191 (7.52)	5.5 (12)
	ASME B16.5, CL 150	90 (3.54)	14.2 (0.56)						
DN 10 (3/8 ⁽⁵⁾)	ASME B16.5, CL 300	95 (3.74)	17.3 (0.68)						
	JIS 10K	90 (3.54)	15 (0.59)						
	EN 1092-1 ⁽⁶⁾ , PN 10 ... 40 ⁽¹⁾	95 (3.74)	19 (0.75)	200 (7.84)	82 (3.23)	255 (10.04)	269 (10.6)	191 (7.52)	5.5 (12)
DN 15 (1/2")	ASME B16.5, CL 150	90 (3.54)	14.2 (0.56)						
	ASME B16.5, CL 300	95.2 (3.75)	17.3 (0.68)						
	JIS 10K	95 (3.74)	15 (0.59)						
	EN 1092-1 ⁽⁶⁾ , PN 10 ... 40 ⁽¹⁾	105 (4.13)	21 (0.83)	200 (7.84)	82 (3.23)	255 (10.04)	269 (10.6)	191 (7.52)	6.5 (14)
DN 20 (3/4")	ASME B16.5, CL 150	98.6 (3.88)	15.7 (0.62)						
	ASME B16.5, CL 300	117.3 (4.62)	18.7 (0.74)						
	JIS 10K	100 (3.94)	17 (0.67)						
	EN 1092-1 ⁽⁶⁾ , PN 10 ... 40 ⁽¹⁾	115 (4.53)	21 (0.83)	200 (7.84)	82 (3.23)	255 (10.04)	269 (10.6)	191 (7.52)	7.5 (16.5)
DN 25 (1")	ASME B16.5, CL 150	108 (4.25)	17.2 (0.68)						
	ASME B16.5, CL 300	124 (4.88)	20.5 (0.81)						
	JIS 10K	125 (4.92)	17 (0.67)						
	EN 1092-1 ⁽⁶⁾ , PN 10 ... 40 ⁽¹⁾	140 (5.51)	21 (0.83)	200 (7.84)	92 (3.62)	262 (10.3)	276 (10.87)	198 (7.80)	8.5 (18.5)
DN 32 (1 1/4")	ASME B16.5, CL 150	117.3 (4.62)	18.7 (0.74)						
	ASME B16.5, CL 300	133.4 (5.25)	22.1 (0.87)						
	JIS 10K	135 (5.31)	19 (0.75)						
	EN 1092-1 ⁽⁶⁾ , PN 10 ... 40 ⁽¹⁾	150 (5.91)	21 (0.83)	200 (7.84)	92 (3.62)	262 (10.3)	276 (10.87)	198 (7.80)	9.5 (21)
DN 40 (1 1/2")	ASME B16.5, CL 150	127 (5.00)	20.5 (0.81)						
	ASME B16.5, CL 300	155.4 (6.12)	23.6 (0.93)						
	JIS 10K	140 (5.51)	19 (0.75)						
	EN 1092-1 ⁽⁶⁾ , PN 10 ... 40 ⁽¹⁾	150 (5.91)	21 (0.83)	200 (7.84)	92 (3.62)	262 (10.3)	276 (10.87)	198 (7.80)	9.5 (21)

Table 16 Dimensions DN 3 ... 40

Tolerance for L: +0 / -3 mm (+0 / -0.018 in.)

... Flowmeter sensor

...Dimensions

Dimensions – Flange device, aluminum sensor housing (shell housing) — Design level 'A'									
Nominal diameter	Process connection	D	B	L ^{2) 3)}	C	F ^{7,8)}	F1 ^{7,8)}	F2 ^{7,8)}	Weight
DN 50 (2")	EN 1092-1 ⁶⁾ , PN 10 ... 40 ¹⁾	165 (6.50)	23 (0.91)	200 (7.87)	97.5 (3.84)	268 (10.55)	282 (11.1)	204 (8.0)	11 (24)
	ASME B16.5, CL 150	152.4 (6.00)	22.1 (0.87)						
	ASME B16.5, CL 300	165.1 (6.50)	25.4 (1.0)						
	JIS 10K	155 (6.10)	19 (0.75)						
	AS2129 table D, E	150 (5.91)	–						8.5 (18.5)
DN 65 (2 1/2")	EN 1092-1 ⁶⁾ , PN 16 ¹⁾	185 (7.28)	22 (0.87)	200 (7.87)	108.5 (4.25)	279 (10.98)	293 (11.54)	215 (8.46)	11.5 (25)
	EN 1092-1 ⁶⁾ , PN 40 ¹⁾	185 (7.28)	26 (1.02)						13.5 (30)
	ASME B16.5, CL 150	177.8 (7.00)	25.4 (1.0)						11.5 (25)
	ASME B16.5, CL 300	190.5 (7.50)	28.4 (1.12)						13.5 (30)
	JIS 10K	175 (6.89)	21 (0.83)						13.5 (30)
	AS2129 table D, E	165 (6.50)	–						–
DN 80 (3")	EN 1092-1 ⁶⁾ , N 10 ... 40 ¹⁾	200 (7.87)	28 (1.10)	200 (7.87)	108.5 (4.27)	279 (10.98)	293 (11.54)	215 (8.46)	15.5 (34)
	ASME B16.5, CL 150	190.5 (7.50)	26.9 (1.06)						15.5 (34)
	ASME B16.5, CL 300	210 (8.27)	31.4 (1.24)						17.5 (38.5)
	JIS 10K	185 (7.28)	21 (0.83)						17.5 (38.5)
	AS2129 table D, E	185 (7.28)	–						–
DN 100 (4")	EN 1092-1 ⁶⁾ PN 16 ¹⁾	220 (8.66)	24 (0.94)	250 (9.84)	122.5 (4.82)	301 (11.85)	315 (12.4)	237 (9.33)	17.5 (38.5)
	EN 1092-1 ⁶⁾ PN 25 ... 40 ¹⁾	235 (9.25)	28 (1.10)						21.5 (47)
	ASME B16.5 CL 150	228.6 (9.00)	27.4 (1.08)						19.5 (43)
	ASME B16.5 CL 300	254 (10.0)	35.8 (1.41)						28.5 (63)
	JIS 10K	210 (8.72)	21 (0.83)						17.5 (38.5)
	AS2129 table D, E	215 (8.46)	–						–

Table 17 Dimensions DN 50 ... 100

Tolerance for L: +0 / -3 mm (+0 / -0,018 in.)

1) Other pressure ratings on request.

2) If a grounding ring is fitted (attached to one side of the flange), dimension L increases as follows: by 3 mm (0.118 inch) for DN 3 ... 100, and by 5 mm (0.197 inch) for DN 125.

3) If protection plates are fitted (attached to both sides of the flange), dimension L increases as follows: by 6 mm (0.236 inch) for DN 3 ... 100, and by 10 mm (0.394 inch) for DN 125.

4) Connection flange DN 10.

5) Connection flange 1/2".

6) Connecting dimensions in accordance with EN 1092-1. For DN 65, PN 16 in accordance with EN 1092-1, please order PN 40.

7) For devices in high-temperature design, dimension F, F1, F2 increases by +127 mm (+5.0 inch).

8) Depending on the device design, the dimensions change according to the following table:

Device design		Dimension F, F1	Dimension F2
Without explosion protection	Standard sensor design	0	0
	High-temperature sensor design	+127 mm (+5 inch)	+127 mm (+5 inch)
Explosion protection Zone 1, Div. 1	Standard sensor design	+74 mm (+2.91 inch)	+47 mm (+1.85 inch)
	High-temperature sensor design	+127 mm (+5 inch)	+174 mm (+6.85 inch)
Explosion protection Zone 2, Div. 2	Standard sensor design	0	0
	High-temperature sensor design	+127 mm (+5 inch)	+127 mm (+5 inch)

Flange DN 125 ... 400 (6 ... 16"), aluminum sensor housing (shell housing) – Design level 'A'

All specified dimensions and weights are in mm (in.) or kg (lb.). The stated weights are approximate; the maximum weight is always stated.

Integral mount design

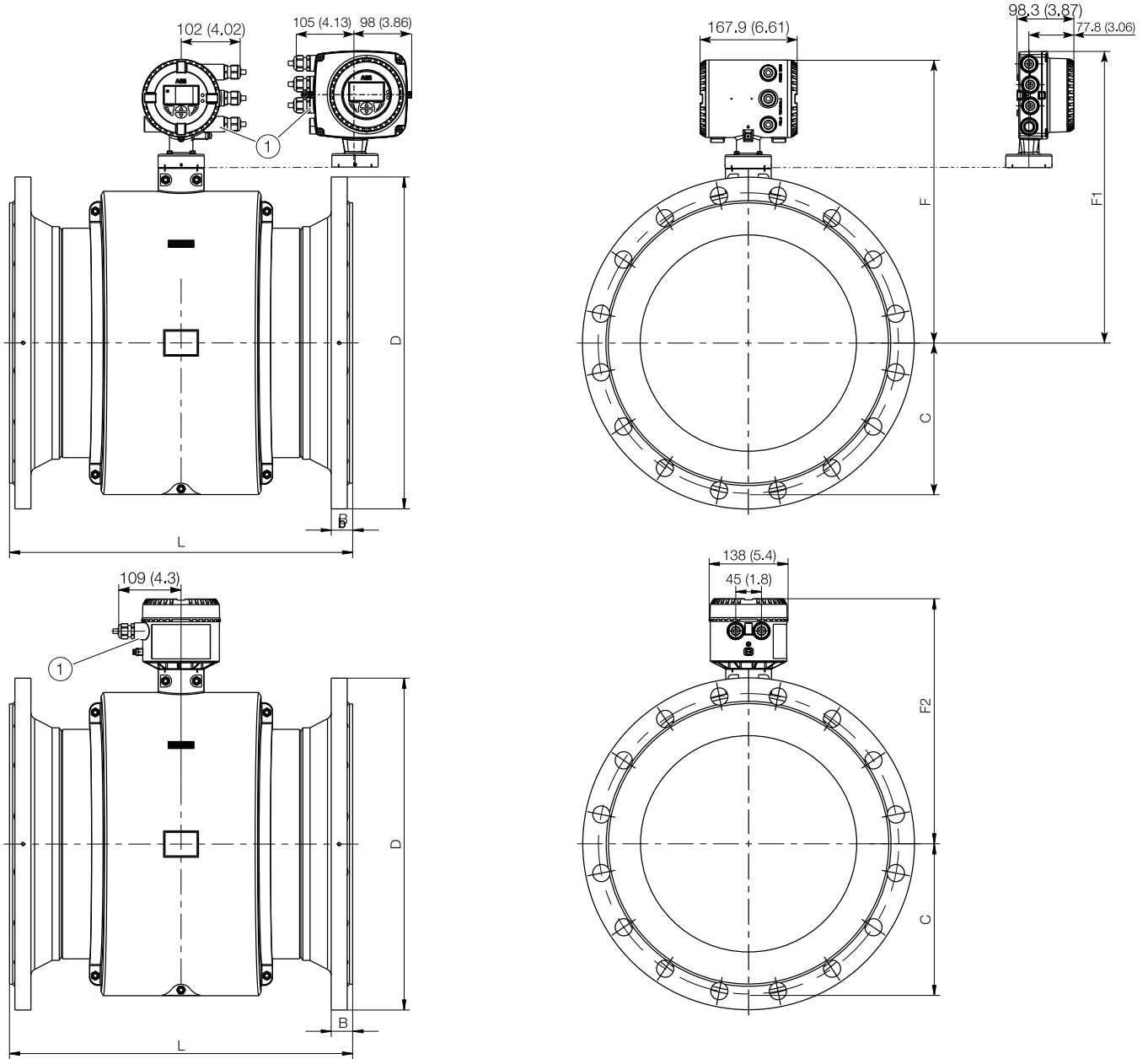

Remote mount design

- ① Female thread (either 1/2" NPT or M20 x 1,5) refer to model coding. With 1/2" NPT there will be a plug instead of the PG cable inlet.

Figure 29 Integral mount design (top), remote mount design (bottom)

... Flowmeter sensor

...Dimensions

...Flange DN 125 ... 400 (6 ... 16"), aluminum sensor housing (shell housing) – Design level 'A'

Dimensions – Flange device, aluminum sensor housing (shell housing) — Design level 'A'

Nominal diameter	Process connection	D	B	L ²⁾³⁾	C	F ^{5,7)}	F1 ^{5,7)}	F2 ^{5,7)}	Weight
DN 125 (5")	EN 1092-1 ⁶⁾ PN 16 ¹⁾	250 (9,84)	25 (0,98)	250 (9,84)	130 (5,12)	311 (12,24)	325 (12,80)	247 (9,72)	20,5 (45)
	EN 1092-1 ⁶⁾ PN 25 ... 40 ¹⁾	270 (10,63)	29 (1,14)						27,5 (60,5)
	ASME B16.5 CL 150	254 (10,0)	27,9 (1,10)						20,5 (45)
	ASME B16.5 CL 300	279,4 (11,0)	39,1 (1,54)	450 (17,72)					33,5 (74)
	JIS 10K	250 (9,84)	27 (1,06)	250 (9,84)					20,5 (45)
	AS2129 table D, E	255 (10,04)	–						–
DN 150 (6")	EN 1092-1 PN 16 ¹⁾	285 (11,22)	25 (0,98)	300 (11,81)	146 (5,75)	358 (14,09)	372 (14,65)	294 (11,57)	31,5 (69,5)
	EN 1092-1 PN 25 ... 40 ¹⁾	300 (11,81)	31 (1,22)						37,5 (82,5)
	ASME B16.5 CL 150	279,4 (11,0)	29,4 (1,16)						31,5 (69,5)
	ASME B16.5 CL 300	317,5 (12,5)	40,5 (1,59)						45,5 (100)
	JIS 10K	280 (11,02)	28 (1,10)						31,5 (69,5)
	AS2129 table D, E	280 (11,02)	–						31,5 (69,5)
DN 200 (8")	EN 1092-1, PN 10 ... 16 ¹⁾	340 (13,39)	28 (1,10)	350 (13,78)	170,5 (6,71)	399 (15,71)	413 (16,26)	334 (13,15)	41,5 (90,5)
	EN 1092-1, PN 25 ¹⁾	360 (14,17)	34 (1,34)						53,5 (118)
	EN 1092-1, PN 40 ¹⁾	375 (14,76)	38 (1,50)						63,5 (151)
	ASME B16.5, CL 150	345 (13,58)	33,6 (1,32)						48,5 (107)
	ASME B16.5, CL 300	380 (14,96)	46,1 (1,81)						70,5 (155,5)
	JIS 10K	330 (12,99)	33 (1,30)						41,5 (90,5)
	AS2129 table D, E	335 (13,19)	–						48,5 (107)
DN 250 (10")	EN 1092-1, PN 10 ¹⁾	395 (15,55)	30 (1,18)	450 (17,72)	198 (7,80)	413 (16,26)	427 (16,81)	349 (13,74)	59,5 (131)
	EN 1092-1, PN 16 ¹⁾	405 (15,94)	30 (1,18)						63,5 (140)
	EN 1092-1, PN 25 ¹⁾	425 (16,73)	36 (1,42)						82,5 (182)
	EN 1092-1, PN 40 ¹⁾	450 (17,72)	42 (1,65)						93,5 (206)
	ASME B16.5, CL 150	405 (15,94)	35,2 (1,39)						68,5 (151)
	ASME B16.5, CL 300	445 (17,52)	52,8 (2,08)						103,5 (228)
	JIS 10K	400 (15,75)	37 (1,46)						63,5 (140)
	AS2129 table D, E	405 (15,94)	–						68,5 (151)
DN 300 (12")	EN 1092-1, PN 10 ¹⁾	445 (17,52)	31 (1,22)	500 (19,68)	228 (8,98)	436 (17,17)	450 (17,72)	372 (14,62)	72,5 (160)
	EN 1092-1, PN 16 ¹⁾	460 (18,11)	33 (1,30)						78,5 (173)
	EN 1092-1, PN 25 ¹⁾	485 (19,09)	39 (1,54)						98,5 (217)
	EN 1092-1, PN 40 ¹⁾	515 (20,28)	47 (1,85)	600 (23,62)					138,5 (305)
	ASME B16.5, CL 150	485 (19,09)	36,8 (1,45)	500 (19,68)					103,5 (228)
	ASME B16.5, CL 300	520 (20,47)	55,8 (2,20)						148,5 (327)
	JIS 10K	450 (17,72)	40 (1,57)						78,5 (173)
	AS2129 table D, E	455 (17,19)	–						103,5 (228)

Table 18 Dimensions DN 125 ... 300

Tolerance for L: +0 / -3 mm (+0 / -0,018 in.)

Dimensions – Flange device, aluminum sensor housing (shell housing) — Design level 'A'									
Nominal diameter	Process connection	D	B	L ^{2) 3)}	C	F ^{5,7)}	F1 ^{5,7)}	F2 ^{5,7)}	Weight
DN 350 (14")	EN 1092-1, PN 10 ¹⁾	505 (19,88)	31 (1,22)	550 (21,65)	267 (10,51)	451 (17,76)	465 (18,31)	416 (16,38)	93,5 (206)
	EN 1092-1, PN 16 ¹⁾	520 (20,47)	35 (1,38)						108,5 (239)
	EN 1092-1, PN 25 ¹⁾	555 (21,85)	43 (1,69)						143,5 (316)
	ASME B16.5, CL 150	535 (21,06)	40,1 (1,58)						128,5 (283)
	ASME B16.5, CL 300	585 (23,03)	58,8 (2,31)						196,5 (433)
	JIS 10K	490 (19,29)	–						108,5 (239)
	AS2129 table D, E	525 (20,67)	–						103,5 (228)
DN 400 (16")	EN 1092-1 PN 10 ¹⁾	565 (22,24)	31 (1,22)	600 (23,62)	267 (10,51)	493 (19,41)	507 (19,96)	416 (16,38)	101,5 (224)
	EN 1092-1 PN 16 ¹⁾	580 (22,83)	37 (1,46)						124,5 (274)
	EN 1092-1 PN 25 ¹⁾	620 (24,41)	45 (1,77)						168,5 (371)
	ASME B16.5 CL 150	595 (23,43)	41,6 (1,64)						173,5 (382)
	ASME B16.5 CL 300	650 (25,59)	62,2 (2,45)						262,5 (579)
	JIS 10K	560 (22,05)	–						124,5 (274)
	AS2129 table D, E	580 (22,83)	–						173,5 (382)

Table 19 Dimensions DN 350 ... 400

Tolerance for L: DN 150 ... 200: +0 / -3 mm (+0 / -0,018 in.), DN 250 ... 400: +0 / -5 mm (+0 / -0,197 in.)

- 1) Other pressure ratings on request.
- 2) If a grounding ring is fitted (attached to one side of the flange) dimension L increases by 5 mm (0.197 inch).
- 3) If protection plates are fitted (attached to both sides of the flange) dimension L increases by 10 mm (0.394 inch).
- 4) For devices in high-temperature design, dimension F, F1, F2 increases by +127 mm (+5.0 inch).
- 5) Depending on the device design, the dimensions change according to the following table.

Device design		Dimension F, F1	Dimension F2
Without explosion protection	Standard sensor design	0	0
	High-temperature sensor design	+127 mm (+5 inch)	+127 mm (+5 inch)
Explosion protection Zone 1, Div. 1	Standard sensor design	+74 mm (+2.91 inch)	+47 mm (+1.85 inch)
	High-temperature sensor design	+127 mm (+5 inch)	+174 mm (+6.85 inch)
Explosion protection Zone 2, Div. 2	Standard sensor design	0	0
	High-temperature sensor design	+127 mm (+5 inch)	+127 mm (+5 inch)

... Flowmeter sensor

...Dimensions

Flange DN 450 ... 600 (18 ... 24"), steel sensor housing Design level 'A'

All specified dimensions and weights are in mm (in.) or kg (lb). The stated weights are approximate; the maximum weight is always stated.

Integral mount design

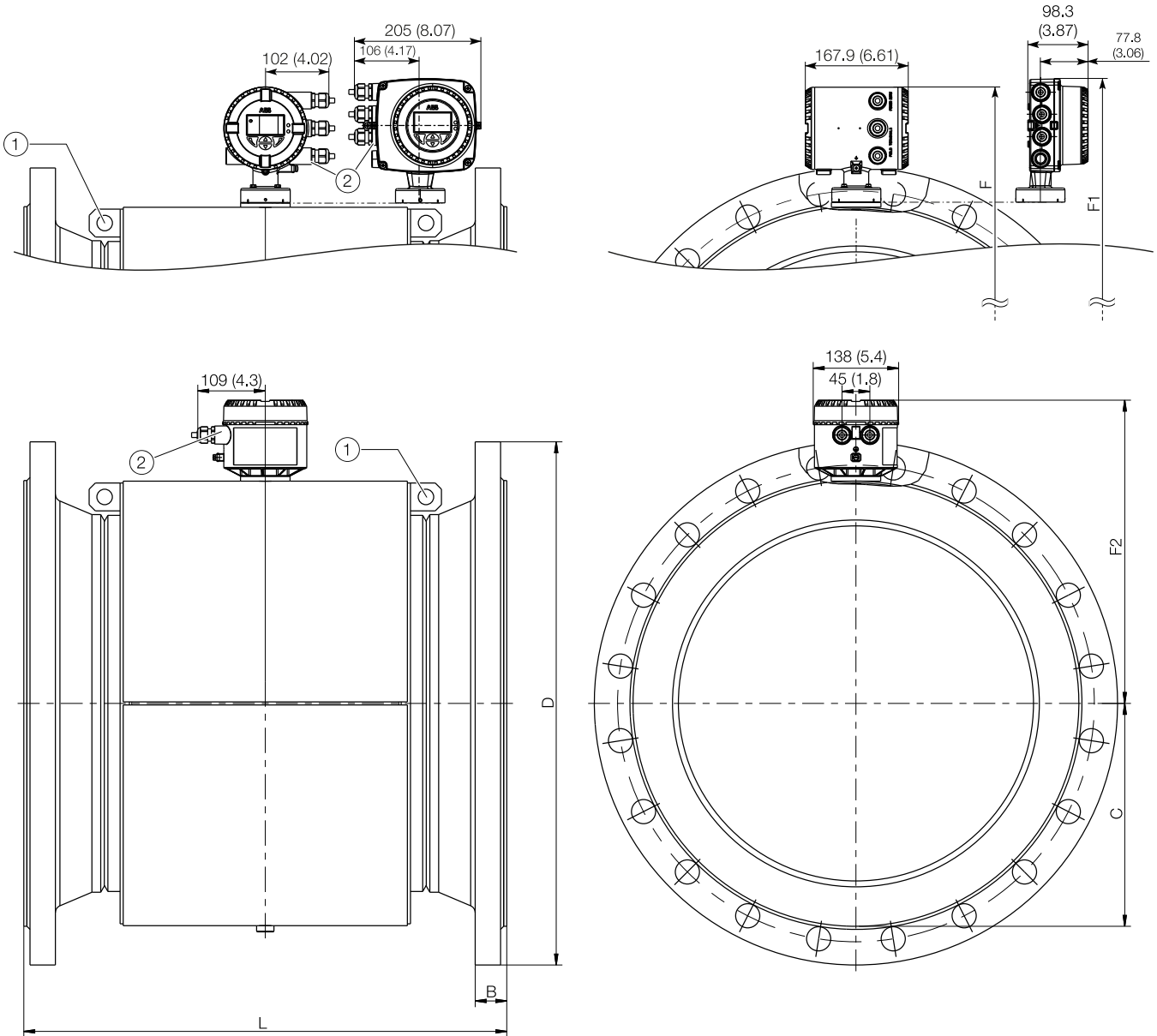

Remote mount design

- ① Transport lugs
- ② Female thread (either 1/2" NPT or M20 x 1,5) refer to model coding. With 1/2" NPT there will be a plug instead of the PG cable inlet.

Figure 30 Integral mount design (top), remote mount design (bottom)

Dimensions – Flange device, steel sensor housing Design level 'A'									
Nominal diameter	Process connection	D	B	L²⁾³⁾	C	F^{5,7)}	F1^{5,7)}	F2^{5,7)}	Weight
DN 450 (18")	ASME B16.5, CL 150	635 (25.0)	44.6 (1.76)	686 (27.01)	310 (12.20)	501 (19.72)	515 (20.28)	437 (17.20)	258.5 (570)
	AS2129 table D, E	640 (25.20)	–						
DN 500 (20")	EN 1092-1, PN 10 ¹⁾	670 (26.38)	33 (1.30)	650 (25.59)	310 (12.20)	501 (19.72)	515 (20.28)	437 (17.20)	188.5 (416)
	EN 1092-1, PN 16 ¹⁾	715 (28.15)	39 (1.54)						238.5 (526)
	ASME B16.5, CL 150	698.5 (27.50)	47.9 (1.89)	762 (30.0)					298.5 (658)
	AS2129 table D, E	705 (27.76)	–	650 (25.59)					
DN 600 (24")	EN 1092-1, PN 10 ¹⁾	780 (30.71)	33 (1.30)	780 (30.71)	361 (14.21)	552 (21.73)	566 (22.28)	490 (19.29)	338.5 (746)
	EN 1092-1, PN 16 ¹⁾	840 (33.07)	41 (1.61)						316.5 (698)
	ASME B16.5, CL 150	812.8 (32.0)	52.8 (2.08)	914 (35.98)					423.5 (934)
	AS2129 table D, E	825 (32.48)	–	780 (30.71)					

Table 20 Dimensions DN 450 ... 600

Tolerance for L: DN450, DN500 +0 / -5 mm (+0 / -0.197 in.) DN 600 +0 / -10 mm (+0 / -0.394 in.)

1) Other pressure ratings on request.

2) If a grounding ring is fitted (attached to one side of the flange) dimension L increases by 5 mm (0.197 in.).

3) If protection plates are fitted (attached to both sides of the flange) dimension L increases by 10 mm (0.394 in.).

4) For devices in high-temperature design, dimension F, F1, F2 increases by +127 mm (+5.0 in.).

5) Depending on the device design, the dimensions change according to the following table.

Device design		Dimension F, F1	Dimension F2
Without explosion protection	Standard sensor design	0	0
	High-temperature sensor design	+127 mm (+5 inch)	+127 mm (+5 inch)
Explosion protection Zone 1, Div. 1	Standard sensor design	+74 mm (+2.91 inch)	+47 mm (+1.85 inch)
	High-temperature sensor design	+127 mm (+5 inch)	+174 mm (+6.85 inch)
Explosion protection Zone 2, Div. 2	Standard sensor design	0	0
	High-temperature sensor design	+127 mm (+5 inch)	+127 mm (+5 inch)

... Flowmeter sensor

...Dimensions

Flange DN 700 ... 2000 (28 ... 80"), steel sensor housing Design level "A", ABB Standard Lay Length (1,3xDN)

All specified dimensions and weights are in mm (in.) or kg (lb). The stated weights are approximate; the maximum weight is always stated.

Integral mount design

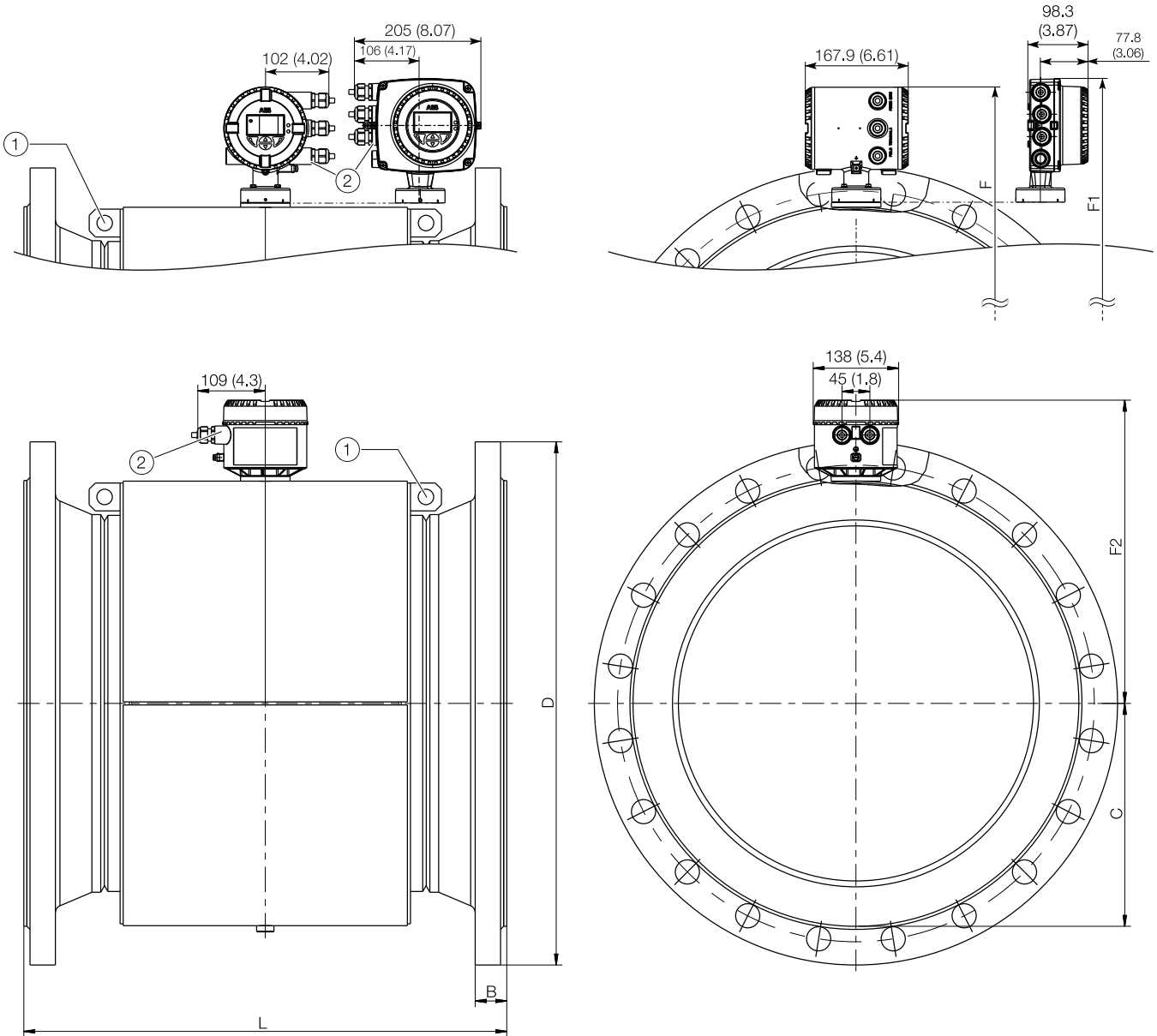

Remote mount design

- ① Transport lugs
- ② Female thread (either 1/2" NPT or M20 x 1,5) refer to model coding. With 1/2" NPT there will be a plug instead of the PG cable inlet.

Figure 31 Integral mount design (top), remote mount design (bottom)

Dimensions – Flange device, steel sensor housing Design level "A" ABB standard lay length (1,3xDN)									
Nominal diameter	Process connection	D	B	L²⁾³⁾	C	F^{5,7)}	F1^{5,7)}	F2^{5,7)}	Weight
DN 700 (28")	EN 1092-1, PN 10 ¹⁾	895 (35.24)	35 (1.38)	910 (35.83)	405 (15.94)	596 (23.46)	610 (24.02)	534 (21.02)	318.5 (702)
	EN 1092-1, PN 16 ¹⁾	910 (35.83)	36 (1.42)						438.5 (967)
	ASME B16.47, CL 150	836.7 (32.94)	49.5 (1.95)						348.5 (768)
DN 750 (30")	ASME B16.5, CL 150	888 (34.96)	44.5 (1.75)	990 (38.96)	431 (16.97)	606 (23.86)	620 (24.41)	560 (22.05)	474.5 (1046)
DN 800 (32")	EN 1092-1, PN 10 ¹⁾	1015 (39.96)	37 (1.46)	1040 (40.94)	455 (17.91)	646 (25.43)	660 (25.98)	584 (22.99)	418.5 (923)
	EN 1092-1, PN 16 ¹⁾	1025 (40.35)	43 (1.69)						488.5 (1077)
	ASME B16.47, CL 150	942 (37.09)	51 (2.01)						498.5 (1099)
DN 900 (36")	EN 1092-1, PN 10 ¹⁾	1115 (43.90)	39 (1.54)	1170 (46.06)	505 (19.88)	696 (27.40)	710 (27.95)	635 (25.0)	503.5 (1110)
	EN 1092-1, PN 16 ¹⁾	1125 (44.29)	45 (1.77)						588.5 (1297)
	ASME B16.47, CL 150	1157.1 (41.62)	57.3 (2.26)						678.5 (1496)
DN 1000 (40")	EN 1092-1, PN 10 ¹⁾	1230 (48.43)	39 (1.54)	1300 (51.18)	555 (21.85)	746 (29.37)	760 (29.92)	685 (26.97)	688.5 (1517)
	EN 1092-1, PN 16 ¹⁾	1255 (49.41)	47 (1.85)						848.5 (1870)
	ASME B16.47, CL 150	1174.8 (46.25)	60.6 (2.39)						878.5 (1937)
DN 1050 (42")	ASME B16.47, CL 150	1067 (42.01)	58.7 (2.31)	1365 (53.74)	607 (23.90)	771 (30.35)	785 (30.91)	737 (29.02)	930.5 (2051)
DN 1100 (44")	ASME B16.47, CL 150	1118 (44.02)	60.5 (2.38)	1430 (56.30)	607 (23.90)	-	-	737 (29.02)	960.5 (2117)
DN 1200 (48")	EN 1092-1, PN 10 ¹⁾	1455 (57.28)	43 (1.69)	1560 (61.42)	660 (25.98)	856 (33.7)	870 (34.25)	791 (31.14)	928.5 (2047)
	EN 1092-1, PN 16 ¹⁾	1485 (58.46)	53 (2.09)						1118.5 (2466)
DN 1400 (56")	EN 1092-1 PN 10 ¹⁾	1675 (65.94)	47 (1.85)	1820 (71.65)	755 (29.72)	950 (37.4)	964 (37.95)	885 (34.84)	1208.5 (2664)
	EN 1092-1 PN 16 ¹⁾	1685 (66.34)	57 (2.24)						1758.5 (3877)
DN 1500 (60")	ASME B16.47, CL 150	1676 (65.98)	76.2 (3.00)	1950 (76.77)	807 (31.77)	996 (39.21)	1010 (39.76)	937 (36.89)	1950.5 (4300)
DN 1600 (64")	EN 1092-1 PN 10 ¹⁾	1915 (75.39)	51 (2.01)	2080 (81.89)	865 (34.06)	1060 (41.73)	1074 (42.28)	996 (39.21)	1628.5 (3590)
	EN 1092-1 PN 16 ¹⁾	1930 (75.98)	63 (2.48)						2148.5 (4737)
DN 1800 (72")	EN 1092-1 PN 10 ¹⁾	2115 (83.27)	55 (2.17)	2340 (92.13)	980 (38.58)	1176 (46.3)	1190 (46.85)	1111 (43.74)	2228.5 (4913)
	EN 1092-1 PN 16 ¹⁾	2130 (83.86)	67 (2.64)						2898.5 (6390)
DN 2000 (80")	EN 1092-1 PN 10 ¹⁾	2325 (91.54)	59 (2.32)	2600 (102.36)	1090 (42.91)	1286 (50.63)	1300 (51.18)	1221 (48.07)	1878.5 (4141)
	EN 1092-1 PN 16 ¹⁾	2345 (92.32)	71 (2.80)						2648.5 (5839)

Table 21 Dimensions DN 700 ... 2000

Tolerance for L: DN 700 ... 2000 +0 / -10 mm (+0 / -0.394 in.)

- 1) Other pressure ratings on request.
- 2) If a grounding ring is fitted (attached to one side of the flange) dimension L increases by 5 mm (0.197 in.).
- 3) If protection plates are fitted (attached to both sides of the flange) dimension L increases by 10 mm (0.394 in.).
- 4) For devices in high-temperature design, dimension F, F1, F2 increases by +127 mm (+5.0 in.).
- 5) Depending on the device design, the dimensions change according to the following table.

Device design		Dimension F, F1	Dimension F2
Without explosion protection	Standard sensor design	0	0
	High-temperature sensor design	+127 mm (+5 inch)	+127 mm (+5 inch)
Explosion protection Zone 1, Div. 1	Standard sensor design	+74 mm (+2.91 inch)	+47 mm (+1.85 inch)
	High-temperature sensor design	+127 mm (+5 inch)	+174 mm (+6.85 inch)
Explosion protection Zone 2, Div. 2	Standard sensor design	0	0
	High-temperature sensor design	+127 mm (+5 inch)	+127 mm (+5 inch)

... Flowmeter sensor

...Dimensions

Flange DN 700 ... 2000 (28 ... 80"), steel sensor housing Design level "A", Optional Lay Length (1,0xDN)

All specified dimensions and weights are in mm (in.) or kg (lb). The stated weights are approximate; the maximum weight is always stated.

Integral mount design

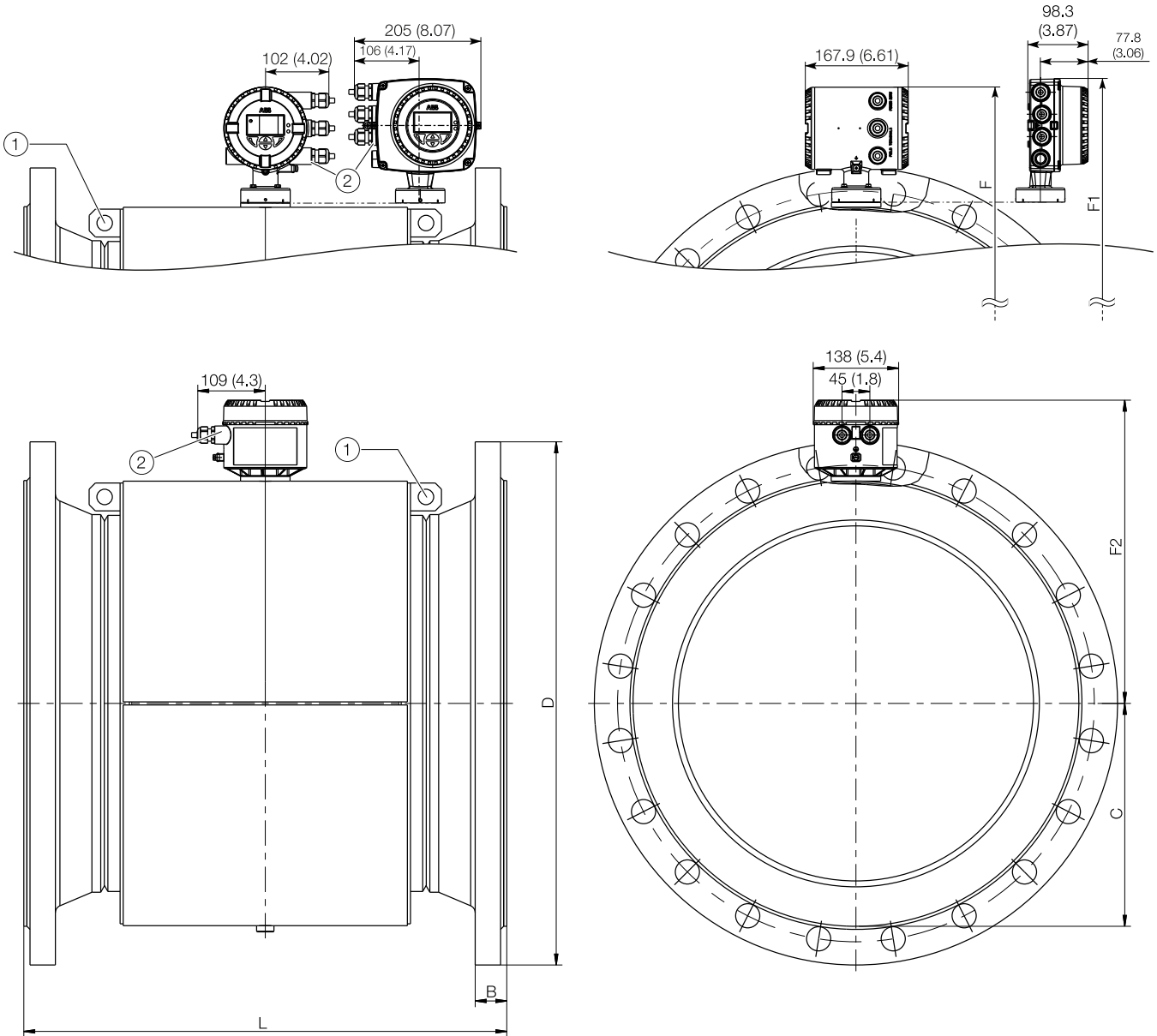

Remote mount design

- ① Transport lugs
- ② Female thread (either 1/2" NPT or M20 x 1,5) refer to model coding. With 1/2" NPT there will be a plug instead of the PG cable inlet.

Figure 32 Integral mount design (top), remote mount design (bottom)

Dimensions – Flange device, steel sensor housing Design level "A" Optional lay length (1,0xDN)									
Nominal diameter	Process connection	D	B	L ²⁾³⁾	C	F ^{5,7)}	F1 ^{5,7)}	F2 ^{5,7)}	Weight
DN 700 (28")	EN 1092-1, PN 10 ¹⁾	895 (35.24)	35 (1.38)	700 (27.56)	405 (15.94)	596 (23.46)	610 (24.02)	534 (21.02)	318.5 (702)
	EN 1092-1, PN 16 ¹⁾	910 (35.83)	36 (1.42)						438.5 (967)
	ASME B16.47, CL 150	836.7 (32.94)	49.5 (1.95)						348.5 (768)
	JIS 5K	875 (34.45)	31 (1.22)						202 (445)
	JIS 10K	905 (35.63)	39 (1.53)						263 (580)
	JIS 7.5K	928 (36.53)	36 (1.42)						320 (705)
	AS 4087 PN16	910 (35.82)	61 (2.40)						327 (720)
	AS2129 TABLE E	910 (35.82)	56 (2.20)						305 (672)
DN 750 (30")	ASME B16.5, CL 150	888 (34.96)	44.5 (1.75)		431 (16.97)	606 (23.86)	620 (24.41)	560 (22.05)	474.5 (1046)
	JIS 5K	945 (37.20)	33 (1.30)	762 (30.00)	431 (16.97)	616 (24.25)	630 (24.8)	570 (22.44)	233 (513)
	JIS 10K	970 (38.19)	41 (1.61)	762 (30.00)	431 (16.97)	616 (24.25)	630 (24.8)	570 (22.44)	306 (675)
	AS 4087 PN16	995 (39.17)	61 (2.40)	762 (30.00)	431 (16.97)	616 (24.25)	630 (24.8)	570 (22.44)	388 (855)
	AS2129 TABLE E	995 (39.17)	59 (2.32)	762 (30.00)	431 (16.97)	616 (24.25)	630 (24.8)	570 (22.44)	377 (831)
DN 800 (32")	EN 1092-1, PN 10 ¹⁾	1015 (39.96)	37 (1.46)	800 (31.45)	455 (17.91)	646 (25.43)	660 (25.98)	584 (22.99)	373 (822)
	EN 1092-1, PN 16 ¹⁾	1025 (40.35)	43 (1.69)						447 (985)
	ASME B16.47, CL 150	942 (37.09)	51 (2.01)						498.5 (1099)
	JIS 5K	995 (39.17)	33 (1.30)						261 (575)
	JIS 10K	1020 (40.16)	41 (1.61)						340 (750)
	JIS 7.5K	1034 (40.71)	39 (1.53)						420 (926)
	AS 4087 PN16	1060 (41.73)	61 (2.40)						442 (974)
	AS2129 TABLE E	1060 (41.73)	59 (2.32)						431 (950)
DN 900 (36")	EN 1092-1, PN 10 ¹⁾	1115 (43.90)	39 (1.54)	900 (35.43)	505 (19.88)	696 (27.40)	710 (27.95)	635 (25.0)	420 (926)
	EN 1092-1, PN 16 ¹⁾	1125 (44.29)	45 (1.77)						510 (1124)
	ASME B16.47, CL 150	1157.1 (41.62)	57.3 (2.26)						678.5 (1495)
	JIS 5K	1095 (43.11)	35 (1.38)						319 (703)
	JIS 10K	1120 (44.10)	43 (1.70)						415 (915)
	JIS 7.5K	1156 (45.51)	41 (1.61)						520 (1146)
	AS 4087 PN16	1175 (46.26)	71 (2.78)						658 (1450)
	AS2129 TABLE E	1175 (46.26)	69 (2.71)						645 (1421)
DN 1000 (40")	EN 1092-1, PN 10 ¹⁾	1230 (48.43)	39 (1.54)	1000 (39.40)	555 (21.85)	746 (29.37)	760 (29.92)	685 (26.97)	580 (1279)
	EN 1092-1, PN 16 ¹⁾	1255 (49.41)	47 (1.85)						780 (1719)
	ASME B16.47, CL 150	1174.8 (46.25)	60.6 (2.39)						878.5 (1937)
	JIS 5K	1195 (47.04)	37 (1.46)						379 (835)
	JIS 10K	1235 (48.62)	45 (1.77)						527 (1162)
	JIS 7.5K	1262 (49.68)	43 (1.70)						660 (1455)
	AS 4087 PN16	1255 (49.41)	71 (2.80)						696 (1534)
	AS2129 TABLE E	1255 (49.41)	72 (2.83)						698 (1539)
DN 1050 (42")	ASME B16.47, CL 150	1067 (42.01)	58.7 (2.31)	1365 (53.74)	607 (23.90)	771 (30.35)	785 (30.91)	737 (29.02)	930.5 (2051)
DN 1100 (44")	ASME B16.47, CL 150	1118 (44.02)	60.5 (2.38)	1430 (56.30)	607 (23.90)	-	-	737 (29.02)	960.5 (2117)
DN 1200 (48")	EN 1092-1, PN 10 ¹⁾	1455 (57.28)	43 (1.69)	1560 (61.42)	660 (25.98)	856 (33.7)	870 (34.25)	791 (31.14)	928.5 (2047)
	EN 1092-1, PN 16 ¹⁾	1485 (58.46)	53 (2.09)						1118.5 (2466)
DN 1400 (56")	EN 1092-1 PN 10 ¹⁾	1675 (65.94)	47 (1.85)	1820 (71.65)	755 (29.72)	950 (37.4)	964 (37.95)	885 (34.84)	1208.5 (2664)
	EN 1092-1 PN 16 ¹⁾	1685 (66.34)	57 (2.24)						1758.5 (3877)
DN 1500 (60")	ASME B16.47, CL 150	1676 (65.98)	76.2 (3.00)	1950 (76.77)	807 (31.77)	996 (39.21)	1010 (39.76)	937 (36.89)	1950.5 (4300)
DN 1600 (64")	EN 1092-1 PN 10 ¹⁾	1915 (75.39)	51 (2.01)	2080 (81.89)	865 (34.06)	1060 (41.73)	1074 (42.28)	996 (39.21)	1628.5 (3590)
	EN 1092-1 PN 16 ¹⁾	1930 (75.98)	63 (2.48)						2148.5 (4737)
DN 1800 (72")	EN 1092-1 PN 10 ¹⁾	2115 (83.27)	55 (2.17)	2340 (92.13)	980 (38.58)	1176 (46.3)	1190 (46.85)	1111 (43.74)	2228.5 (4913)
	EN 1092-1 PN 16 ¹⁾	2130 (83.86)	67 (2.64)						2898.5 (6390)
DN 2000 (80")	EN 1092-1 PN 10 ¹⁾	2325 (91.54)	59 (2.32)	2600 (102.36)	1090 (42.91)	1286 (50.63)	1300 (51.18)	1221 (48.07)	1878.5 (4141)
	EN 1092-1 PN 16 ¹⁾	2345 (92.32)	71 (2.80)						2648.5 (5839)

Table 22 Dimensions DN 700 ... 2000

Tolerance for L: DN 700 ... 2000 +0 / -10 mm (+0 / -0.394 in.)

- 1) Other pressure ratings on request.
- 2) If a grounding ring is fitted (attached to one side of the flange) dimension L increases by 5 mm (0.197 in.).
- 3) If protection plates are fitted (attached to both sides of the flange) dimension L increases by 10 mm (0.394 in.).
- 4) For devices in high-temperature design, dimension F, F1, F2 increases by +127 mm (+5.0 in.).
- 5) Depending on the device design, the dimensions change according to the following table.

Device design		Dimension F, F1	Dimension F2
Without explosion protection	Standard sensor design	0	0
	High-temperature sensor design	+127 mm (+5 inch)	+127 mm (+5 inch)
Explosion protection Zone 1, Div. 1	Standard sensor design	+74 mm (+2.91 inch)	+47 mm (+1.85 inch)
	High-temperature sensor design	+127 mm (+5 inch)	+174 mm (+6.85 inch)
Explosion protection Zone 2, Div. 2	Standard sensor design	0	0
	High-temperature sensor design	+127 mm (+5 inch)	+127 mm (+5 inch)

... Flowmeter sensor

...Dimensions

Flange DN 15 ... 400 (1/2 ... 16"), high pressure design, aluminum sensor housing (shell housing) — Design level 'A'

All specified dimensions and weights are in mm (in.) or kg (lb). The stated weights are approximate; the maximum weight is always stated.

Integral mount design

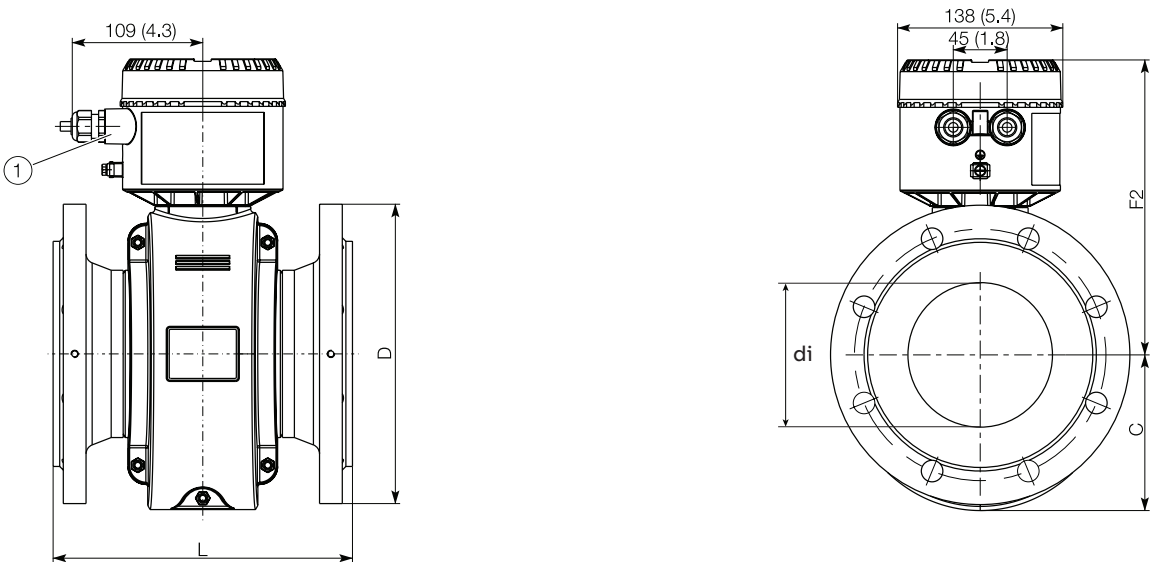
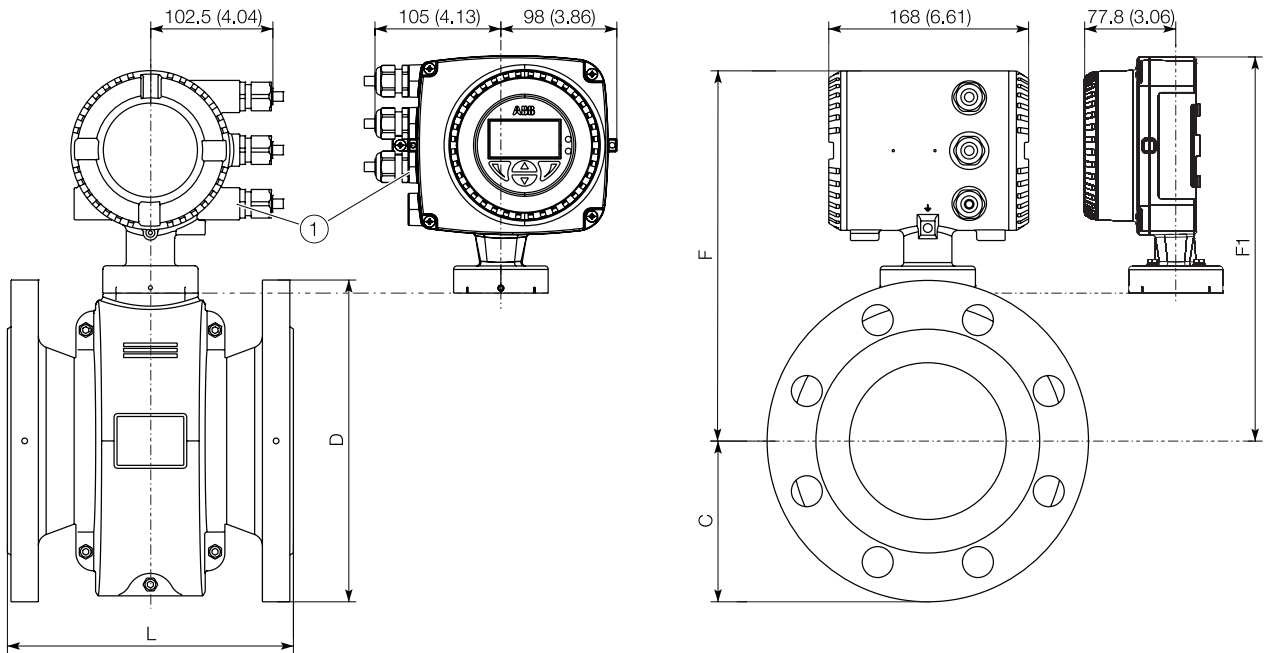

Remote mount design

① Female thread (either 1/2" NPT or M20 x 1,5) refer to model coding. With 1/2" NPT there will be a plug instead of the PG cable inlet.

Figure 33 Integral mount design (top), remote mount design (bottom)

DN	Process connection	Dimensions mm (inch)									Approx. weight kg (lb)	
		D	di	Schedule	L ¹⁾²⁾	F ³⁾	C	F1 ³⁾	F2 ³⁾	A	Integral	Remote
25 (1")	EN1092-1 PN63	140	22		270						12	10
	EN1092-1 PN100	(5.51)	(0.87)		(10.63)						(27)	(22)
	ASME B16.5, CL 600	124	22	40	270	255	82	269	191	113	12	10
	ASME B 16.5 CL900/1500	(4.88)	(0.87)	(1.57)	(10.63)	(10.04)	(3.23)	(10.6)	(7.52)	(4.45)	(26)	(22)
	ASME B 16.5 CL900/1500	149	19	80	300						15	13
ASME B16.5, CL 2500	(5.87)	(0.75)	(3.15)	(11.81)						(33)	(29)	
ASME B16.5, CL 2500	158	15	160	350						18	16	
ASME B16.5, CL 2500	(6.22)	(0.60)	(6.30)	(13.78)						(40)	(35)	
40 (1 1/2")	EN1092-1 PN63	170	36		280						13 / 14	11 / 12
	EN1092-1 PN100	(6.69)	(1.42)		(11.02)						(29 / 31)	(24 / 27)
	ASME B16.5, CL 600	156	35	40	280	262	92	276	198	113	13	11
	ASME B 16.5 CL900/1500	(6.14)	(1.38)	(1.57)	(11.02)	(10.31)	(3.62)	(10.87)	(7.80)	(4.45)	(29)	(24)
	ASME B 16.5 CL900/1500	177	26	80	350						22	20
ASME B16.5, CL 2500	(6.97)	(1.02)	(3.15)	(13.78)						(48.5)	(44)	
ASME B16.5, CL 2500	203	22	XXS	400						32	32	
ASME B16.5, CL 2500	(7.99)	(0.87)	XXS	(15.75)						(70.5)	(70.5)	
50 (2")	EN1092-1 PN63	180	48		280						15	13
	EN1092-1 PN100	(7.09)	(1.89)		(11.02)						(33)	(29)
	EN1092-1 PN100	195	48		280						18	16
	ASME B16.5, CL 600	(7.68)	(1.89)		(11.02)						(40)	(35)
	ASME B16.5, CL 600	165	46	40	280	268	97	282	204	115	15	13
ASME B 16.5 CL900/1500	(6.50)	(1.81)	(1.57)	(11.02)	(10.55)	(3.82)	(11.1)	(8.0)	(4.53)	(33)	(29)	
ASME B 16.5 CL900/1500	216	37	160	400						32	30	
ASME B16.5, CL 2500	(8.50)	(1.46)	(6.30)	(15.75)						(70.5)	(66)	
ASME B16.5, CL 2500	235	32	XXS	450						42	40	
ASME B16.5, CL 2500	(9.25)	(1.26)	XXS	(17.72)						(92.5)	(88)	

Table 23 Dimensions DN 15 (1/2") ... 50 (2")

Tolerance L: DN 25 ... 100 +0 / -5 mm (+0 / -0,197 inch), DN 150 ... 200 +0 / -5 mm (+0 / -0,197 inch), DN 250 ... 400 +0 / -8 mm (+0 / -0,314 inch)

Tolerance Di: ETFE Liner: +1/ -5 mm (+1/ -0,197 inch) Hardrubber: +1/ -3 mm (+1/ -0.118 inch)

All pressure ratings (PN63, PN100, CL600 ... CL2500 available with Hardrubber and ETFE only

... Flowmeter sensor

...Dimensions

...Flange DN 15 ... 400 (1/2 ... 16"), high pressure design, aluminum sensor housing (shell housing) — Design level 'A'

All specified dimensions and weights are in mm (in.) or kg (lb). The stated weights are approximate; the maximum weight is always stated.

DN	Process connection	Dimensions mm (inch)									Approx. weight kg (lb)		
		D	di	Schedule	L ^{1) 2)}	F ³⁾	C	F1 ³⁾	F2 ³⁾	A	Integral	Remote	
65 (2 1/2")	EN1092-1 PN63	205 (8.07)	64 (2.52)	--	330 (12.99)							18 (40)	16 (35)
	EN1092-1 PN100	220 (8.66)	63 (2.48)	--	330 (12.99)							23 (51)	21 (46)
	ASME B16.5, CL 600	190 (7.48)	60 (2.36)	30	330 (12.99)	279 (10.98)	108 (4.25)	293 (11.54)	215 (8.46)	104 (4.09)		20 (44)	18 (40)
	ASME B 16.5 CL900/1500	244 (9.61)	48 (1.89)	160	400 (15.75)							37 (81.5)	35 (77)
	ASME B16.5, CL 2500	266 (10.47)	39 (1.53)	XXS	450 (17.72)							56 (123.5)	54 (119)
80 (3")	EN1092-1 PN63	215 (8.46)	76 (2.99)	--	340 (13.39)							22 (49)	20 (44)
	EN1092-1 PN100	230 (9.06)	75 (2.95)	--	340 (13.39)							26 (57)	24 (53)
	ASME B16.5, CL 600	209 (8.23)	72 (2.83)	40	340 (13.39)	279 (10.98)	108 (4.25)	293 (11.54)	215 (8.46)	104 (4.09)		25 (55)	23 (51)
	ASME B16.5, CL 900	241 (9.49)	68 (2.67)	80	400 (15.75)							38 (84)	36 (80)
	ASME B16.5, CL 1500	266 (10.47)	61 (2.40)	160	400 (15.75)							51 (112)	49 (108)
	ASME B16.5, CL 2500	305 (12.01)	52 (2.05)	XXS	500 (19.68)							84 (185)	82 (181)
100 (4")	EN1092-1 PN63	250 (9.84)	100 (3.94)	--	400 (15.75)							29 (64)	27 (60)
	EN1092-1 PN100	265 (10.43)	98 (3.85)	--	400 (15.75)							38 (84)	26 (57)
	ASME B16.5, CL 600	273 (10.75)	91 (3.58)	80	400 (15.75)	301 (11.85)	122 (4.8)	315 (12.4)	237 (9.33)	125 (4.92)		46 (101)	44 (97)
	ASME B16.5, CL 900	292 (11.50)	86 (3.38)	120	400 (15.75)							58 (128)	56 (123.5)
	ASME B16.5, CL 1500	311 (12.24)	74 (2.91)	XXS	420 (16.54)							75 (165)	73 (161)
	ASME B16.5, CL 2500	355 (13.98)	68 (2.67)	--	600 (23.62)							128 (282)	126 (278)
125 (5")	EN1092-1 PN63	295 (11.61)	124 (4.88)	--	400 (15.75)							70 (154)	68 (150)
	EN1092-1 PN100	315 (12.4)	121 (4.76)	--	450 (17.72)							70 (154)	68 (150)
	ASME B16.5, CL 600	330 (12.99)	116 (4.56)	80	400 (15.75)	311 (12.24)	130 (5.12)	325 (12,80)	247 (9,72)	125 (4.92)		70 (154)	68 (150)
	ASME B16.5, CL 900	349 (13.74)	110 (4.33)	120	450 (17.72)							88 (194)	86 (190)
	ASME B16.5, CL 1500	374 (14.72)	97 (3.82)	XXS	500 (19.68)							127 (280)	125 (275)
	ASME B16.5, CL 2500	419 (16.50)	85 (3.34)	--	700 (27.56)							206 (454)	204 (450)
150 (6")	EN1092-1 PN63	345 (13.58)	151 (5.94)	--	450 (17.72)							94 (207)	92 (203)
	EN1092-1 PN100	355 (13.98)	148 (5.83)	--	450 (17.72)							94 (207)	92 (203)
	ASME B16.5, CL 600	355 (13.98)	140 (5.51)	80	450 (17.72)	358 (14.09)	146 (5.75)	372 (14,65)	294 (11,57)	166 (6.54)		94 (207)	92 (203)
	ASME B16.5, CL 900	381 (15.0)	140 (5.51)	80	500 (19.68)							120 (265)	118 (260)
	ASME B16.5, CL 1500	393 (15.47)	118 (4.64)	XXS	600 (23.62)							168 (370)	166 (366)
	ASME B16.5, CL 2500	482 (18.98)	102 (4.01)	--	800 (31.50)							335 (738)	333 (734)

Table 24 Dimensions DN 65 (2 1/2") ... 150 (6")

Tolerance L: DN 25 ... 100 +0 / -5 mm (+0 / -0,197 inch), DN 150 ... 200 +0 / -5 mm (+0 / -0,197 inch), DN 250 ... 400 +0 / -8 mm (+0 / -0,314 inch)

Tolerance Di: ETFE Liner: +1/ -5 mm (+1/ - 0,197 inch) Hardrubber: +1/ -3 mm (+1/ -0.118 inch)

All pressure ratings (PN63, PN100, CL600 ... CL2500 available with Hardrubber and ETFE only)

All specified dimensions and weights are in mm (in.) or kg (lb). The stated weights are approximate; the maximum weight is always stated.

DN	Process connection	Dimensions mm (inch)									Approx. weight kg (lb)		
		D	di	Schedule	L ^{1) 2)}	F ³⁾	C	F1 ³⁾	F2 ³⁾	A	Integral	Remote	
200 (8")	EN1092-1 PN63	415 (16.34)	199 (7.83)	--	450 (17.72)							150 (331)	148 (326)
	EN1092-1 PN100	430 (16.93)	193 (7.60)	--	500 (19.68)							150 (331)	148 (326)
	ASME B16.5, CL 600	419 (16.50)	188 (7.40)	80	500 (19.68)	399 (15.71)	170 (6.69)	413 (16,26)	334 (13,15)	200 (7.87)		150 (331)	148 (326)
	ASME B16.5, CL 900	470 (18.50)	176 (6.93)	120	600 (23.62)							207 (456)	205 (452)
	ASME B16.5, CL 1500	482 (18.98)	163 (6.42)	--	700 (27.56)							290 (639)	288 (635)
	ASME B16.5, CL 2500	552 (21.73)	141 (5.55)	--	950 (37.40)							510 (1124)	508 (1120)
250 (10")	ASME B16.5, CL 600	508 (20.0)	236 (9.29)	80	600 (23.62)								
	ASME B16.5, CL 900	546 (21.5)	224 (8.82)	120	700 (27.56)	413 (16.26)	198 (7.80)	427 (16,81)	349 (13,74)	235 (9.25)		On request	
	ASME B16.5, CL 1500	584 (22.99)	203 (7.99)	--	850 (33.46)								
	ASME B16.5, CL 2500	673 (26.50)	177 (6.97)	--	1200 (47.24)								
300 (12")	ASME B16.5, CL 600	559 (22.01)	283 (11.14)	80	750 (29.53)								
	ASME B16.5, CL 900	609 (23.98)	267 (10.51)	120	800 (31.50)	436 (17.17)	228 (8.98)	450 (17,72)	372 (14,62)	272 (10.71)		On request	
	ASME B16.5, CL 1500	673 (26.50)	238 (9.37)	--	950 (37.40)								
	ASME B16.5, CL 2500	762 (30.00)	214 (8.42)	--	1400 (55.12)								
350 (14")	ASME B16.5, CL 600	603 (23.74)	311 (12.24)	80	750 (29.53)								
	ASME B16.5, CL 900	641 (25.24)	294 (11.57)	120	850 (33.46)	451 (17.76)	265 (10.43)	465 (18,31)	416 (16,38)	322 (12.68)		On request	
	ASME B16.5, CL 1500	749 (29.49)	269 (10.59)	--	1050 (41.34)								
400 (16")	ASME B16.5, CL 600	686 (27.01)	357 (14.05)	80	800 (31.50)								
	ASME B16.5, CL 900	705 (27.76)	338 (13.31)	120	900 (35.43)	493 (19.41)	265 (10.43)	507 (19,96)	416 (16,38)	322 (12.68)		On request	
	ASME B16.5, CL 1500	825 (32.48)	310 (12.20)	--	1100 (43.31)								

Table 25 Dimensions DN 200 (8") ... 400 (16")

Tolerance L: DN 25 ... 100 +0 / -5 mm (+0 / -0,197 inch), DN 150 ... 200 +0 / -5 mm (+0 / -0,197 inch), DN 250 ... 400 +0 / -8 mm (+0 / -0,314 inch)

Tolerance Di: ETFE Liner: +1/ -5 mm (+1/ - 0,197 inch) Hardrubber: +1/ -3 mm (+1/ -0.118 inch)

All pressure ratings (PN63, PN100, Cl600 ... CL2500 available with Hardrubber and ETFE only

- 1) If a grounding plate is installed (attached to one side of the flange), this increases dimension L as follows: DN 3 ... 100 by 3 mm (0.118 inch); DN 125 by 5 mm (0.197 inch).
- 2) If protection plates are installed (attached to both sides of the flange), this increases dimension L as follows: DN 3 ... 100 by 6 mm (0.236 inch); DN 125 by 10 mm (0.394 inch).
- 3) Depending on the device design, the dimensions change according to the following table.

Device design		Dimension F, F1	Dimension F2
Without explosion protection	Standard sensor design	0	0
	High-temperature sensor design	+127 mm (+5 inch)	+127 mm (+5 inch)
Explosion protection Zone 1, Div. 1	Standard sensor design	+74 mm (+2.91 inch)	+47 mm (+1.85 inch)
	High-temperature sensor design	+127 mm (+5 inch)	+174 mm (+6.85 inch)
Explosion protection Zone 2, Div. 2	Standard sensor design	0	0
	High-temperature sensor design	+127 mm (+5 inch)	+127 mm (+5 inch)

Transmitter

Features

- 4 ... 20 mA current output
- Current output in the event of an alarm can be configured to 21 ... 22.6 mA (NAMUR NE43)
- Measuring range: Can be configured between 0.02 ... $2 \times Q_{max, DN}$
- Operating mode for flow measurement can be configured
- Programmable digital output. Can be configured as frequency output, pulse output or binary output.
- Two slots for optional plug-in cards for retrofitting additional current / digital outputs or a digital input.
- Damping: 0.04 ... 100 s configurable (1τ)
- Low flow cut-off: 0 ... 20 % for current and pulse output
- Parameterization by means of HART communication
- Empty pipe detection¹⁾
- Simulation of current and binary output (manual process execution)

¹⁾ Requirements for Empty Pipe detector function:
 The conductivity of the fluid must be $\geq 20 \mu S/cm$
 Nominal diameter must be $\geq DN 10$

LCD indicator (option)

- High-contrast LCD indicator
- Display of the current flow rate as well as the total flow rate
- Application-specific visualizations which the user can select. Two operator pages can be configured to display multiple values in parallel.
- Plain text fault diagnostics
- Menu-guided parameterization with four buttons
- 'Easy Set-up' function for fast commissioning
- Parameterization of the device through the front glass with the housing closed

Isolation of outputs

The digital output terminals 41 / 42 and 51 / 52 have a common ground.

The current output and the digital outputs are electrically isolated from each other.

Optional plug-in cards

The transmitter has two slots (OC1, OC2) in which plug-in cards can be inserted to provide additional inputs and outputs. The slots are located on the transmitter motherboard and can be accessed after removing the front housing cover.

Plug-in card	Description
	Current output, 4 to 20 mA passive (red) Order no.: 3KQZ400029U0100
	Passive digital output (green) Order no.: 3KQZ400030U0100
	Passive digital input (yellow) Order no.: 3KQZ400032U0100
	Loop power supply 24 V DC (blue) Order no.: 3KQZ400031U0100
	Modbus RTU RS485 (white) Order no.: 3KQZ400028U0100
	PROFIBUS DP (white) Order no.: 3KQZ400027U0100
	Ethernet IP, Modbus Order no.: 3KQZ400037U0100
	Power over Ethernet (POE) Order no.: 3KQZ400039U0100

IP rating

In accordance with EN60529: IP 65 / IP 67, NEMA 4X

Vibration

In accordance with EN 60068-2

- In the 10 ... 58 Hz range, max. deflection 0.15 mm (0.006 inch)¹⁾
- In the range of 58 ... 150 Hz, max. acceleration 2 g¹⁾

1) Peak load

Temperature data

	Standard	Optional
Ambient temperature	-20 ... 60 °C (-4 ... 140 °F)	-40 ... 70 °C (-40 ... 158 °F)
Storage temperature	-40 ... 70 °C (-40 ... 158 °F)	

NOTICE

When operating below -20°C (-4 °F), the LCD display can no longer be read. Full functionality is assured at temperatures above -20°C (-4 °F).

Housing design

Integral mount design

Housing	Cast aluminum, painted
Paint	≥ 80 µm thick, RAL 9002 (gray white)
Cable gland ¹⁾	Polyamide Stainless steel ²⁾

Remote mount design

Housing	Cast aluminum, painted
Paint	≥ 80 µm thick, RAL 9002 (gray white)
Cable gland ¹⁾	Polyamide Stainless steel ²⁾
Weight	4.5 kg (9.92 lb)

1) Cable gland with M 20 x 1.5 or NPT thread, to be selected via the order number.

2) On explosion-proof design for ambient temperature of -40 °C (-40 °F).

Transmitter

Dimensions

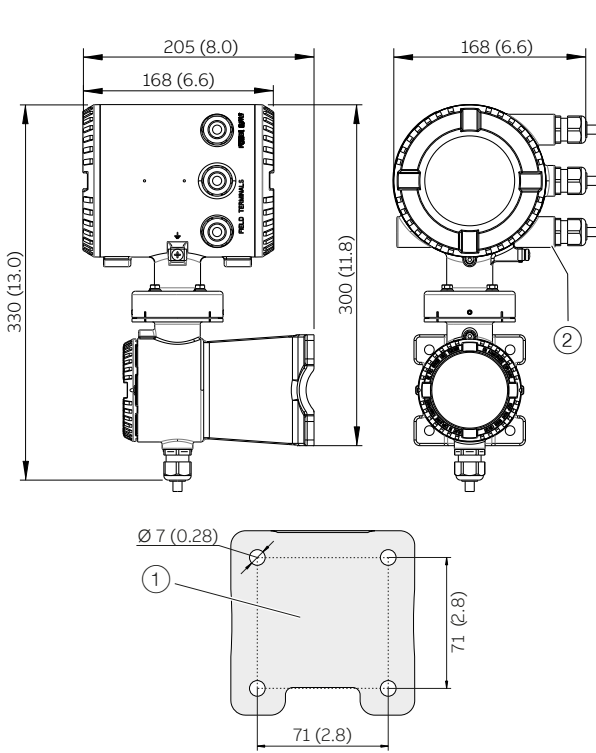

Figure 34 Mounting dimensions of double-compartment housing

Pos.	Description
①	Hole pattern for mounting holes
②	Female thread (either 1/2" NPT or M20 x 1,5) refer to model coding. With 1/2" NPT there will be a plug instead of the PG cable inlet.

Table 26 Legend

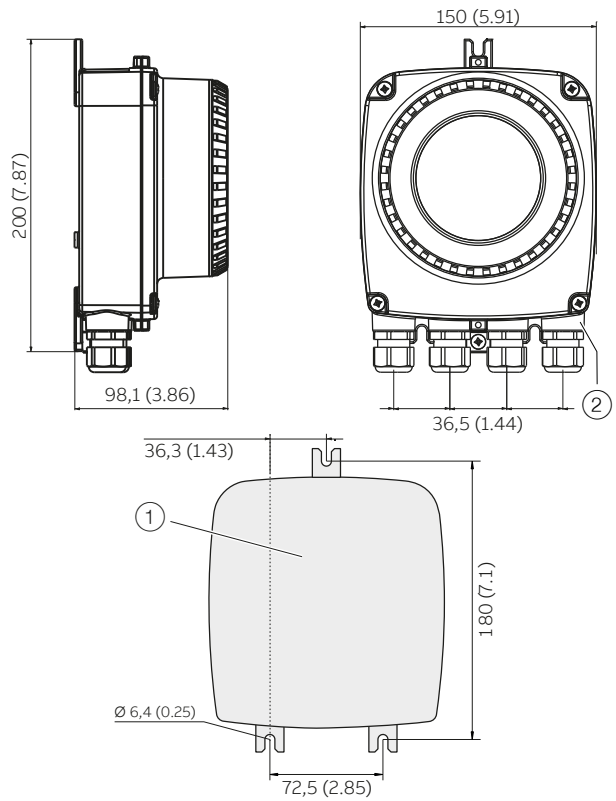

Figure 35 Mounting dimensions single-compartment housing

Pos.	Description
①	Hole pattern for mounting holes
②	Female thread (either 1/2" NPT or M20 x 1,5) refer to model coding. With 1/2" NPT there will be a plug instead of the PG cable inlet

Table 27 Legend

Electrical connections

Connection diagram

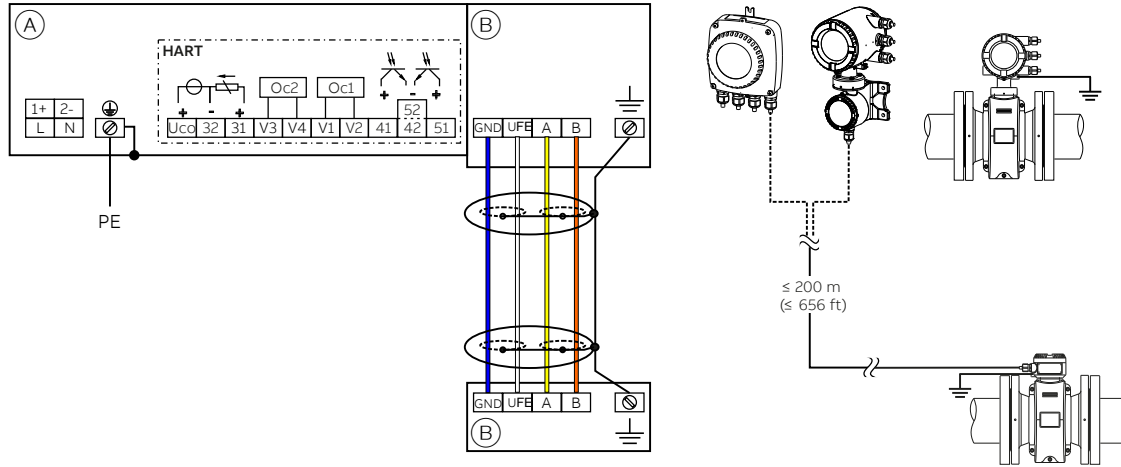

Figure 36 Electrical connections

Pos.	Description
①	Connections for power supply and inputs / outputs
②	Connections for signal cable (remote mount design only)

Table 28 Legend

NOTICE

For detailed information about grounding the transmitter and the flowmeter sensor, please refer to chapter 'Grounding' in the Commissioning instruction or the operating instruction.

Connections for the power supply

AC voltage	
Terminal	Function / comments
L	Phase
N	Neutral conductor
PE / ⊕	Protective earth (PE)
⚡	Potential equalization

AC voltage	
Terminal	Function / comments
1+	+
2-	-
PE / ⊕	Protective earth (PE)
⚡	Potential equalization

Connections for inputs and outputs

Terminal	Function / comments
Uco / 32	Active 4 ... 20 mA current output / HART
31 / 32	Passive 4 ... 20 mA current output / HART
41 / 42	Passive digital output DO1
51 / 52	Passive digital output DO2
V1 / V2	Plug-in card, slot Oc1
V3 / V4	Plug-in card, slot Oc2

For details, see chapter "Optional plug-in cards" on page 46.

Connecting the signal cable

Only for remote mount design.

The sensor housing and transmitter housing must be connected to potential equalization.

Terminal	Function / comments
UFE	Sensor power supply
GND	Ground
A	Data line
B	Data line
⚡	Functional earth / Shielding

... Electrical connections

Electrical data for inputs and outputs

Power supply

AC power supply	
Terminals	L / N
Operating voltage	100 ... 240 V AC (-15 % / +10 %), 47 ... 64 Hz
Power consumption	S_{max} : < 20 VA
Power-up current	18.4 A, $t < 3$ ms

DC voltage supply	
Terminals	1+ / 2-
Operating voltage	16.8 ... 30 V DC
Ripple	< 5 %
Power consumption	P_{max} : < 20 W
Power-up current	21 A, $t < 10$ ms

HART communication

A HART DTM in accordance with FDT1.2 standards is available. HART protocol based Integrations in other Tools or systems (e.g., Emerson AMS/Siemens PCS7) are available on request. The DTM, the DD and EDD is available for download from www.abb.com/flow.

HART output	
Terminals	Active: Uco / 32 Passive: 31 / 32
Protocol	HART 7.1
Transmission	FSK modulation on current output 4 ... 20 mA in accordance with Bell 202 standard
Baud rate	1200 baud
Signal amplitude	Maximum 1.2 mAss
Current output load	Minimum 250 Ω
Cable	0,25 mm ² (AWG 24), twisted
Maximum cable length	1200 m (3937 ft)

For information on communication via the HART protocol, refer to HART® communication in Operating Instruction [OI/FEP630/FEH630-EN](#).

Current output U_{co} / 32, 31 / 32

Can be configured for outputting mass flow and volume flow via the on-site software.

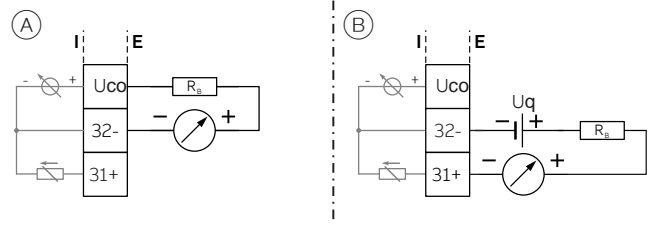

- (A) Active current output U_{co} / 32, active
- (B) Passive current output 31 / 32, passive

Figure 37 (I = internal, E = external, RB = load, Uq = Source voltage)

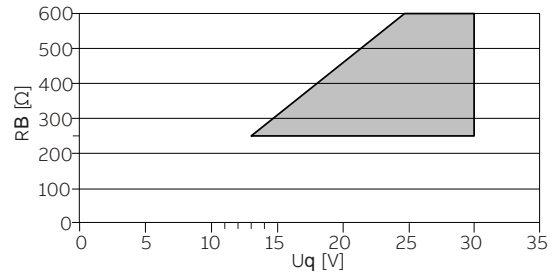

Permissible source voltage U_q for passive outputs in relation to load resistance R_b where I_{max} = 22 mA. ■ = Permissible range

Figure 38 Source voltage for passive outputs

	Active	Passive
Terminals	Uco / 32	31 / 32
Output signal	4 ... 20 mA or 4 ... 12 ... 20 mA, switchable	4 ... 20 mA
Load R _b	250 Ω ≤ R _b ≤ 300 Ω	250 Ω ≤ R _b ≤ 600 Ω
Source voltage U _q ¹⁾	•	13 V ≤ U _q ≤ 30 V
Measuring error	< 0.1 % of measured value	
Resolution	0.4 μA per digit	
Isolation	The current output and the digital outputs are electrically isolated from each other.	

Table 29 Electrical data current output Uco / 32, 31 / 32

1) The source voltage U_q depends on the load R_b and must be within the permissible range.

Digital output 41 / 42, 51 / 52

Can be configured as pulse, frequency or binary output via onsite software.

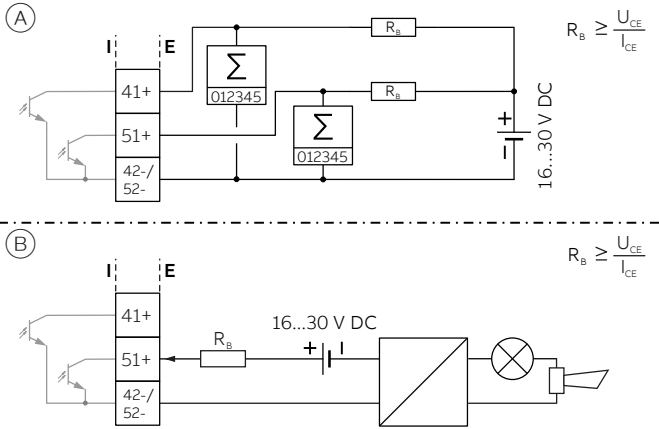

- (A) Passive digital output 41 / 42, 51 / 52 as pulse or frequency output
- (B) Passive digital output 51 / 52 as binary output

Figure 39 (I = internal, E = external, R_b = load)

Pulse / frequency output (passive)	
Terminals	41 / 42, 51 / 52
Output 'closed'	$0\text{ V} \leq U_{CEL} \leq 3\text{ V}$ For $f < 2.5\text{ kHz}$: $2\text{ mA} < I_{CEL} < 30\text{ mA}$ For $f > 2.5\text{ kHz}$: $10\text{ mA} < I_{CEL} < 30\text{ mA}$
Output 'open'	$16\text{ V} \leq U_{CEH} \leq 30\text{ V DC}$ $0\text{ mA} \leq I_{CEH} \leq 0.2\text{ mA}$
f_{max}	10.5 kHz
Pulse width	0.1 ... 2000 ms
Binary output (passive)	
Terminals	41 / 42, 51 / 52
Output 'closed'	$0\text{ V} \leq U_{CEL} \leq 3\text{ V}$ $2\text{ mA} \leq I_{CEL} \leq 30\text{ mA}$
Output 'open'	$16\text{ V} \leq U_{CEH} \leq 30\text{ V DC}$ $0\text{ mA} \leq I_{CEH} \leq 0.2\text{ mA}$
Switching function	Parameterization possible See Menu: Input/Output in Operating Instruction OI/FEP630/FEH630-EN

Table 30 Electrical data digital output 41 / 42, 51 / 52

NOTICE

- The Terminals 42 / 52 have a common ground. Digital outputs DO 41 / 42 and DO 51 / 52 are not electrically isolated from each other. If an additional electrically isolated digital output is required, a corresponding plug-in module must be used.
- If you are using a mechanical counter, we recommend setting a pulse width of $\geq 30\text{ ms}$ and a maximum frequency of $f_{max} \leq 3\text{ kHz}$.

Current output V1 / V2, V3 / V4 (plug-in card)

Up to **two additional** current outputs can be implemented via the 'Passive current output (red)' plug-in card.

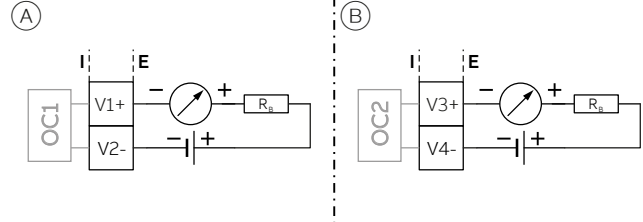

- (A) Passive current output V1 / V2, passive
- (B) Passive current output V3 / V4, passive

Figure 40 (I = internal, E = external, R_b = load)

The plug-in card can be used in slot OC1 or in OC2.

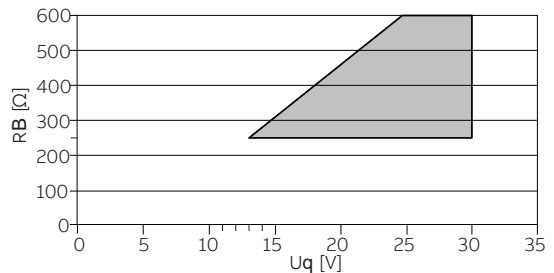

Permissible source voltage U_q for passive outputs in relation to load resistance R_b where $I_{max} = 22\text{ mA}$. ■ = Permissible range

Figure 41 Source voltage for passive outputs

Passive current output	
Terminals	V1 / V2, V3 / V4
Output signal	4 ... 20 mA
Load R_b	$250\ \Omega \leq R_b \leq 600\ \Omega$
Source voltage U_q^*	$13\text{ V} \leq U_q \leq 30\text{ V}$
Measuring error	$< 0.1\%$ of measured value
Resolution	0.4 μA per digit

Table 31 Electrical data current output V1 / V2, V3 / V4

1) The source voltage U_q is dependent of the load R_b and must be placed in an additional area.

... Electrical connections

Digital output V1 / V2, V3 / V4 (plug-in card)

The 'digital output passive (green)' plug-in card can be used to create one additional binary output.

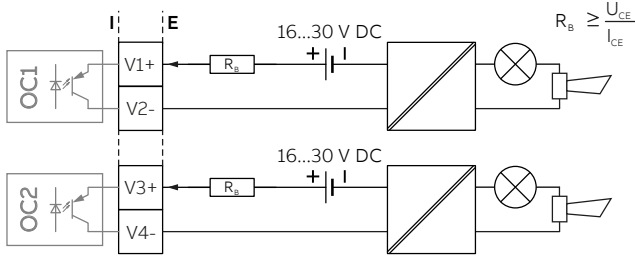

Figure 42 Plug-in card as binary output (I = internal, E = external, R_b = load)

The plug-in module can be used in slot OC1 or OC2.

Binary output (passive)

Terminals	V1 / V2, V3 / V4
Output 'closed'	$0 V \leq U_{CEH} \leq 3 V$ $2 mA < I_{CEH} < 30 mA$
Output 'open'	$16 V \leq U_{CEH} \leq 30 V DC$ $0 mA \leq I_{CEH} \leq 0.2 mA$
Switching function	Parameterization possible See Menu: Input/Output in Operating Instruction OI/FEP630/FEH630-EN

Table 32 Electrical data digital output V1 / V2, V3 / V4

Digital input V1 / V2, V3 / V4 (plug-in card)

A digital input can be implemented via the 'Passive digital input (yellow)' plug-in module.

The plug-in module can be used in slot OC1 or OC2.

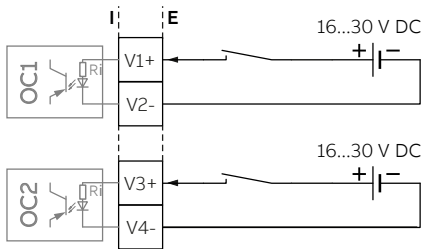

Figure 43 Plug-in card as digital input (I = internal, E = external)

Digital input

Terminals	V1 / V2, V3 / V4
Input 'On'	$16 V \leq U_{KL} \leq 30 V$
Input 'Off'	$0 V \leq U_{KL} \leq 3 V$
Internal resistance R_i	6.5 k Ω
Function	Parameterization possible See Menu: Input/Output in Operating Instruction OI/FEP630/FEH630-EN

Table 33 Electrical data digital input V1 / V2, V3 / V4

24 V DC power supply V1 / V2 (plug-in module)

Use of the 'loop power supply (blue)' plug-in card allows a passive output on the transmitter to be used as an active output. See chapter "Connection examples" on page 53.

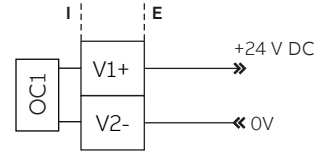

Figure 44 (I = Internal, E = External)

The plug-in module can only be used in slot OC1

Loop power supply 24 V DC

Terminals	V1 / V2
Function	For active connection of passive outputs
Output voltage	24 V DC at 0 mA, 17 V DC at 25 mA
Load rating I_{max}	25 mA, permanently short circuit-proof

Table 34 Electrical data plug-in card 24 V DC power supply V1 / V2

NOTICE

When using the device in potentially explosive atmospheres, the power supply plug-in card must only be used to power one passive output. It must not be connected to multiple passive outputs.

Modbus / PROFIBUS DP interface V1 / V2 (plug-in card)

A Modbus or PROFIBUS DP interface can be implemented by using the 'Modbus RTU, RS485 (white)' or 'PROFIBUS DP, RS485 (white)' plug-in cards.

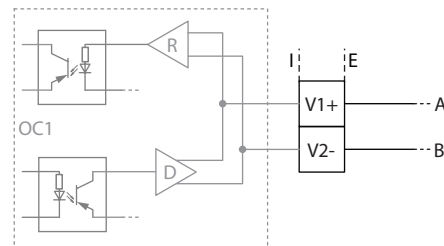

Figure 45 Plug-in card as a Modbus / PROFIBUS DP interface (I = internal, E = external)

The corresponding plug-in card can only be used in slot OC1.

For information on communication through the Modbus or PROFIBUS DP protocols, refer to chapters **Modbus®** communication and **PROFIBUS DP®** communication in Operating Instruction [OI/FEP630/FEH630-EN](#).

Connection examples

Input and output functions are configured via the device software in accordance with the desired application. See **Parameter descriptions** in Operating Instruction [OI/FEP630/FEH630-EN](#).

Active digital output 41 / 42, 51 / 52, V3 / V4

When the 'loop power supply 24 V DC (blue)' plug-in card is used, the digital outputs on the basic device and on the plug-in cards can also be wired as active digital outputs.

NOTICE

Each 'loop power supply (blue)' plug-in card must only power one output.

It must not be connected to two outputs (e.g. digital output 41 / 42 and 51 / 52).

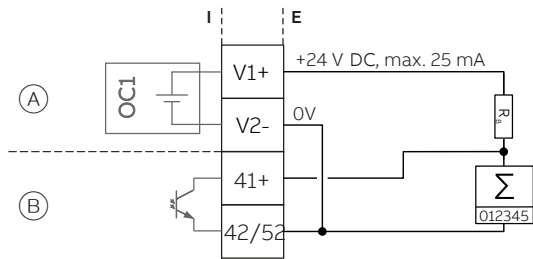

- (A) 'Loop power supply (blue)' plug-in card in slot 1
- (B) Digital output, digital output 41 / 42

Figure 46 Active digital output 41 / 42 (example)

The connection example shows usage for digital output 41 / 42; the same applies to usage for digital output 51 / 52.

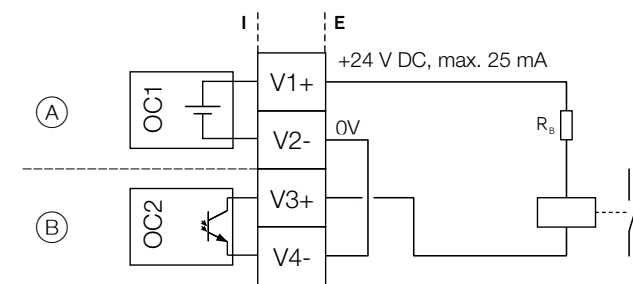

- (A) 'Loop power supply (blue)' plug-in card in slot 1
- (B) 'Digital output (green)' plug-in card in slot 2

Figure 47 Active digital output V3 / V4 (example)

Digital output 41 / 42, 51 / 52 passive on distributed control system

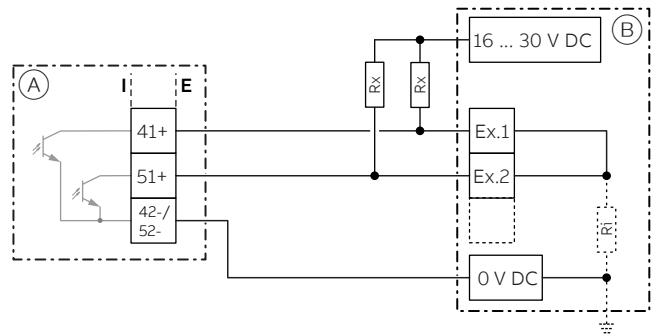

- (A) Transmitter
- (B) Distributed control system / Memory programmable controller
- Ex. 1 Input 1
- Ex. 2 Input 2
- R_x Resistor for current limitation
- R_i Distributed control system internal resistance

Figure 48 Digital output 41 / 42, 51 / 52 passive connected to a Process Control System (Example)

The R_x resistors limit the maximum current through the optoelectronic coupler of the digital outputs in the transmitter. The maximum permissible current is 25 mA. An R_x value of 1000 Ω / 1 W is recommended at a voltage level of 24 V DC. The input on the distributed control system is reduced from 24 V DC to 0 V DC (falling edge) with '1' at the digital output.

... Electrical connections

Active current output V3 / V4

When the 'loop power supply 24 V DC, blue' plug-in card is used, the current output on the plug-in card can also be wired as the active current output.

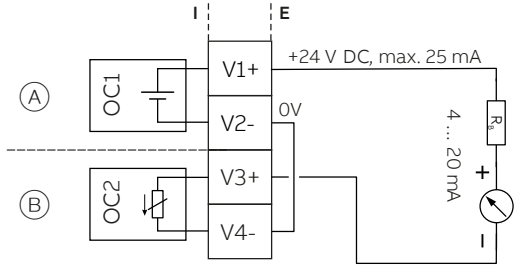

- Ⓐ 'Loop power supply (blue)' plug-in card in slot 1
- Ⓑ 'Passive current output (red)' plug-in card in slot 2

Figure 49 Active current output V3 / V4 (example)

Digital input V3 / V4 active

When the 'loop power supply 24 V DC, blue' plug-in card is used, the current output on the plug-in card can also be wired as the active current output.

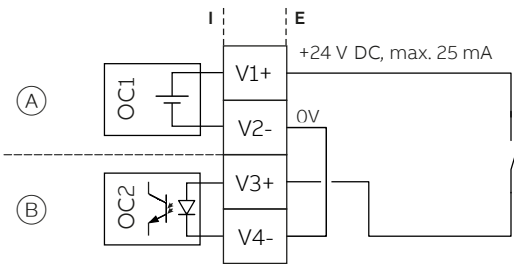

- Ⓐ Plug-in card 'Power supply (blue)' in slot 1
- Ⓑ Plug-in card 'Passive digital input (yellow)' in slot 2

Figure 50 Active digital output V3 / V4 (example)

Connection versions digital output 41 / 42, 51 / 52

Depending on the wiring of digital outputs DO 41 / 42 and 51 / 52, they can be used parallel or only individually. The electrical isolation between the digital outputs also depends on the wiring.

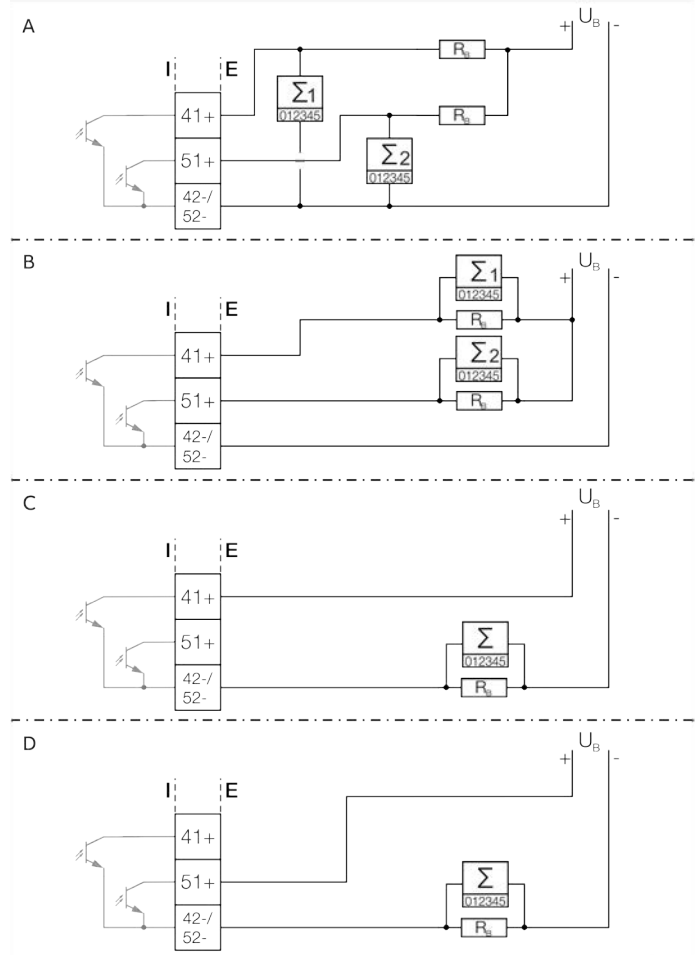

Figure 51 Connection versions digital output 41 / 42 and 51 / 52

	DO 41 / 42 and 51 / 52 can be used parallel	DO 41 / 42 and 51 / 52 electrically isolated
Ⓐ	Yes	No
Ⓑ	Yes	Yes
Ⓒ	No, only DO 41 / 42 can be used	No
Ⓓ	No, only DO 51 / 52 can be used	No

Table 35 Connection versions digital output

Digital communication

HART communication

Note

The HART® protocol is not secure, as such the intended application should be assessed to ensure that these protocols are suitable before implementation.

In connection with the DTM (Device Type Manager) available to the device, communication (configuration, parameterization) can be carried out FDT 0.98 or 1.2 (DSV401 R2).

Other tool or system integrations (e.g. Emerson AMS / Siemens PCS7) on request.

The necessary DTMs and other files can be downloaded from www.abb.com/flow.

HART output	
Terminals	Active: Uco / 32 Passive: 31 / 32
Protocol	HART 7.1
Transmission	FSK modulation on current output 4 to 20 mA in accordance with the Bell 202 standard
Baud rate	1200 baud
Signal amplitude	Maximum 1.2 mA

Factory setting of the HART process variables

HART process variable	Process value
Primary Value (PV)	Q _m – Mass flow
Secondary Value (SV)	Q _v – Volume flow rate
Tertiary Value (TV)	p – Density
Quaternary Value (QV)	T _m – Measuring medium temperature

The process values of the HART variables can be set in the device menu.

Modbus communication

Note

The Modbus® protocol is not secure, as such the intended application should be assessed to ensure that these protocols are suitable before implementation.

Modbus is an open standard owned and administrated by an independent group of device manufacturers styled the Modbus Organization (www.modbus.org).

Using the Modbus protocol allows devices made by different manufacturers to exchange information via the same communication bus, without the need for any special interface devices to be used.

Modbus protocol	
Terminals	V1 / V2
Configuration	Via the Modbus interface or via the local operating interface in connection with Asset Vision Basic (DAT200) and a corresponding Device Type Manager (DTM)
Transmission	Modbus RTU - RS485 serial connection
Baud rate	2400, 4800, 9600, 19200, 38400, 56000, 57600, 115200 baud Factory setting: 9600 baud
Parity	None, even, odd Factory setting: odd
Stop bit	One, two Factory setting: One
IEEE format	Little endian, big endian Factory setting: Little endian
Typical response time	< 100 ms
Response delay time	0 to 200 milliseconds Factory setting: 10 milliseconds

... Electrical connections

...Digital communication

...Modbus communication

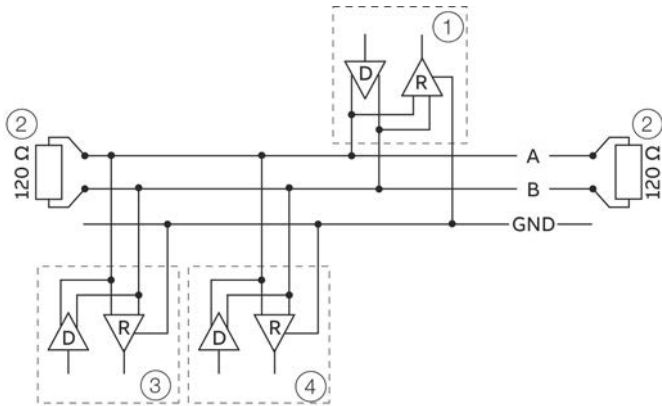

- ① Modbus master
- ② Terminating resistor
- ③ Modbus slave 1
- ④ Modbus slave n to 32

Figure 52 Communication with the Modbus protocol

Cable specification

The maximum permissible length is dependent on the baud rate, the cable (diameter, capacity and surge impedance), the number of loads in the device chain, and the network configuration (2 core or 4-core).

- At a baud rate of 9600 and with a conductor cross-section of at least 0.14 mm² (AWG 26), the maximum length is 1000 m (3280 ft).
- When using a 4-core cable as a 2-wire wiring system, the maximum length must be halved.
- The spur lines must be short, a maximum of 20 m (66 ft).
- When using a distributor with 'n' connections, each branch must have a maximum length of 40 m (131 ft) divided by 'n.'

The maximum cable length depends on the type of cable used. The following standard values apply:

- Up to 6 m (20 ft): cable with standard shielding or twisted-pair cable.
- Up to 300 m (984 ft): double twisted-pair cable with overall foil shielding and integrated earth cable.
- Up to 1200 m (3937 ft): double twisted-pair cable with individual foil shielding and integrated earth cables.
Example: Belden 9729 or equivalent cable.

A category 5 cable can be used for Modbus RS485 up to a maximum length of 600 m (1968 ft). For the symmetrical pairs in RS485 systems, a surge impedance of more than 100 Ω is preferred, especially at a baud rate of 19200 and above.

PROFIBUS DP communication

Note

The PROFIBUS DP protocol are not secure, as such the intended application should be assessed to ensure that these protocols are suitable before implementation.

PROFIBUS DP interface

Terminals	V1 / V2
Configuration	Via the PROFIBUS DP interface or via the local operating interface in connection with Asset Vision Basic (DAT200) and a corresponding Device Type Manager (DTM)
Transmission	In accordance with IEC 61158-2
Baud rate	9.6 kbps, 19.2 kbps, 45.45 kbps, 93.75 kbps, 187.5 kbps, 500 kbps, 1.5 Mbps
	The baud rate is automatically detected and does not need to be configured manually
Device profile	PA Profile 3.02
Bus address	Address range 0 to 126 Factory setting: 126

For commissioning purposes, you will need a device driver in EDD (Electronic Device Description) or DTM (Device Type Manager) format plus a GSD file.

You can download EDD, DTM and GSD from: www.abb.com/flow.

The files required for operation can also be downloaded from www.profibus.com.

ABB provides three different GSD files which can be integrated in the system.

ID number	GSD file name	
0x9740	PA139740.gsd	1xAI, 1xTOT
0x9700	PA139700.gsd	1AI
0x3432	ABB_3432.gsd	6xAI, 2xTOT, 1xAO, 1xDI, 1xDO

Users decide at system integration whether to install the full range of functions or only part. Switching is made using the 'Ident Nr. Selector' parameter.

See also **Ident Nr. Selector** in Operating Instruction OI/FEP630/FEH630-EN.

Limits and rules when using ABB Fieldbus accessories

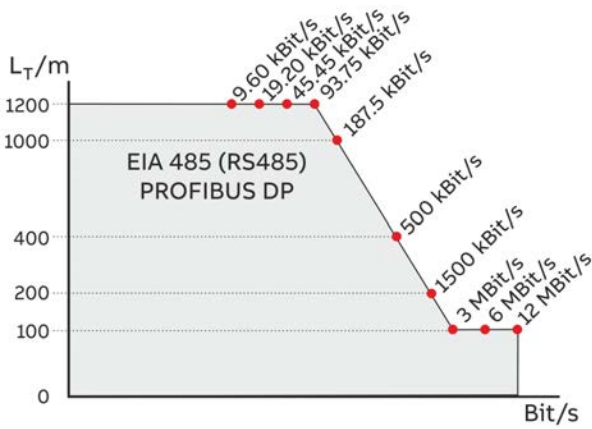

Figure 53 Bus cable length depends on the transmission rate

Pro PROFIBUS Line

(Line = Starts at DP Master and goes to last DP/PA Slave)

- Approximately 4 to 8 DP segments through the repeater (see repeater data sheets)
- Recommended DP transfer rate 500 to 1500 kBit/s
- The slowest DP node determines the transfer rate of the DP line
- Number of PROFIBUS DP and PA nodes ≤ 126 (addresses 0 to 125)

Per PROFIBUS DP segment

- Number of DP nodes ≤ 32 (Node = Devices with / without PROFIBUS address)
- Bus termination required at the beginning and end of each DP segment!
- Trunk cable length (LT) see diagram (length dependent on transfer rate)
- Cable length of at least 1 m between two DP nodes at ≥ 1500 kBit/s
- Spur cable length (LS), at ≤ 1500 kBit/s: LS ≤ 0.25 m, at > 1500 kBit/s: LS = 0.00 m!
- At 1500 kBit/s and ABB DP cable type A:
 - Sum of all spur cable lengths (LS) ≤ 6.60 m, trunk cable length (LT) > 6.60 m, total length = LT + (Σ LS) ≤ 200 m, maximum 22 DP nodes (= 6.60 m / (0.25 m + 0.05 m spare))

... Electrical connections

...Digital communication

Ethernet IP communication



Figure 54 Ethernet communication plug-in card

One port connection without power over Ethernet

Terminal designation:

Port	Pin	Function	Color coding
1	Pin 1	RD+	White/Orange
1	Pin 2	RD-	Orange
1	Pin 3	TD+	White/Green
1	Pin 4	TD-	Green

Standard Ethernet 10/100 BASE-T/TX (IEEE802.3) single port connection.

One port connection with power over Ethernet

Terminal designation:

Port	Pin	Function	Color coding
1	Pin 1	RD+	White/Orange
1	Pin 2	RD-	Orange
1	Pin 3	TD+	White/Green
1	Pin 4	TD-	Green
2	Pin 1	DC+	White/Blue
2	Pin 2	DC-	Blue
2	Pin 3	DC-	White/Brown
2	Pin 4	DC-	Brown

Standard Ethernet 10/100 BASE-T/TX (IEEE802.3) single port connection.

Two port connection without power over Ethernet

Terminal designation:

Port	Pin	Function	Color coding
1	Pin 1	RD+	White/Orange
1	Pin 2	RD-	Orange
1	Pin 3	TD+	White/Green
1	Pin 4	TD-	Green
2	Pin 1	RD+	White/Orange
2	Pin 2	RD-	Orange
2	Pin 3	TD+	White/Green
2	Pin 4	TD-	Green

Ethernet communication

Equipped with an Ethernet Card, ProcessMaster/HygienicMaster 630 provides 2 Ethernet Ports supporting a Ring, Star and Daisy Chain Network configuration.

In addition to the Ethernet Card, a plug-in Card providing 'Power over Ethernet' is available. This Card allows to power the 24 V DC Version of the flowmeter through Ethernet without the need for additional power supply.

Ethernet/IP protocol

Note.

The Ethernet/IP protocol is not secure, as such. The application should be assessed before Implementation to ensure the protocol is suitable.

ProcessMaster and HygienicMaster's Ethernet IP protocol implemented, supports cyclic Communication. Process Variables, Diagnostic Data and Device Status Information can be accessed cyclically.

For Device Configuration a Webserver is available providing full access to all parameter and diagnostic data.

Further Ethernet communication protocols

Note

The device supports following security modes:

Secured Protocols:

Webserver https:

Security modes

Used ports by Webserver: TCP 443

Security is based on .x509 Certificates

Protocol could be deactivated via HMI.

Unsecured protocols:

EtherNet/IP and Modbus TCP

Used ports by EtherNet/IP: TCP 44818, UDP 2222

Used ports by Modbus/TCP: TCP 502

All protocols can be enabled / disabled in the HMI Menu.Ethernet

Ethernet IP Interface	
Configuration	Through the Webserver or the local operating Interface (Display).
EtherNet/IP ProductCode	5002
EDS file	FEW530_FEPFEH630_01_01.eds
Device profile	Profile 0x43, Generic Device, (keyable).
Supporte standards and protocols	Common Industrial Protocol (CIP™) Vol1, Ed 3.25 EtherNet/IP Adaptation of CIP™, Vol2, Ed 1.23
Cable	Cat 5

Operation in Zone 1, 21 / Div 1

Electrical connections

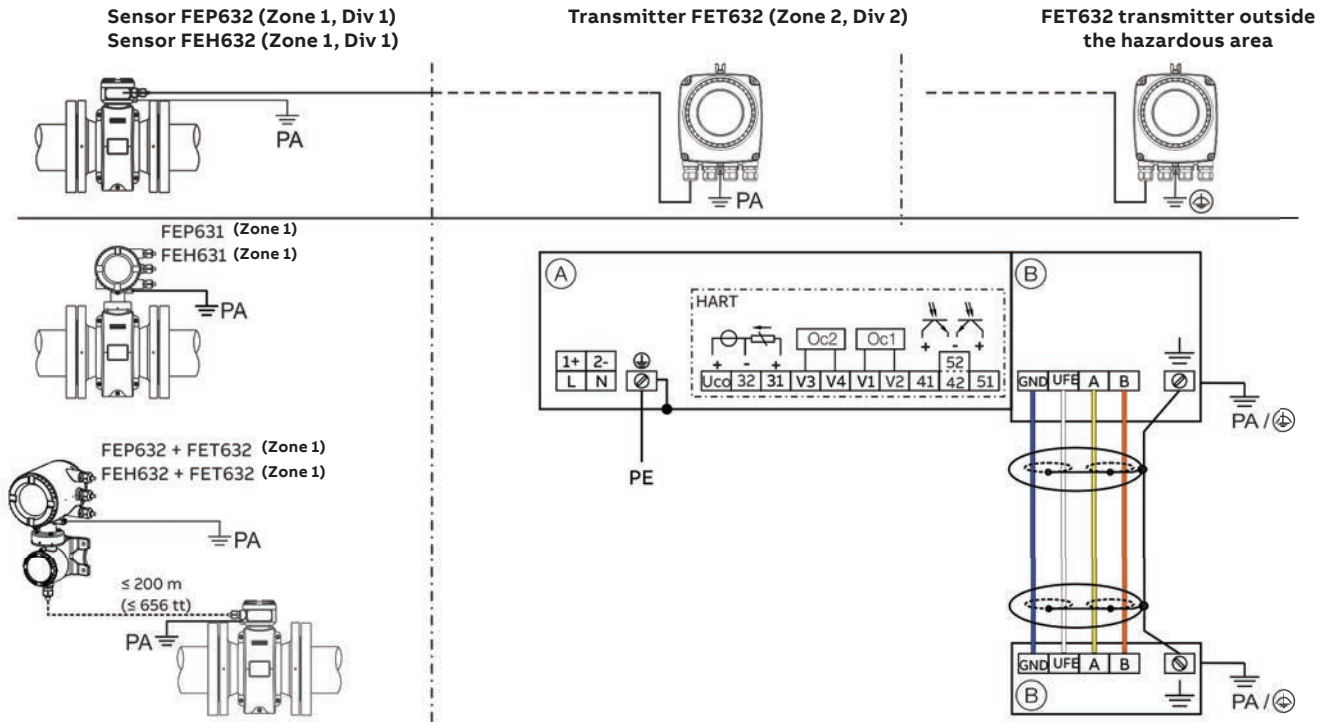

(A) Transmitter

(B) Sensor

Figure 55 Electrical connections

Note

For detailed information on grounding the transmitter and the sensor, please refer to the operating or commissioning instruction.

Connections for the power supply

AC power supply	
Terminal	Function / comments
L	Phase
N	Neutral conductor
PE / ⊕	Protective earth (PE)
PA	Potential equalization

DC voltage supply	
Terminal	Function / comments
1+	+
2-	-
PE / ⊕	Protective earth (PE)
PA	Potential equalization

Connections for inputs and outputs

Terminal	Function / comments
Uco / 32	Current output 4 to 20 mA- / HART output, active
31 / 32	Current output 4 to 20 mA- / HART output, passive
41 / 42	Passive digital output DO1
51 / 52	Passive digital output DO2
V1 / V2	Plug-in card, slot OC1
V3 / V4	Plug-in card, slot OC2

Plug-in cards may not be retrofitted in devices with explosion protection on-site – loss of Ex Approval.

Optional plug-in cards

See page 60.

Configuring the current output

Current output terminals 31 / 32 / Uco can be operated on-site in active or passive mode through appropriate switching.

- Terminal Uco / 32 Current output 4 to 20 mA- / HART output, active
- Terminal 31 / 32 Current output 4 to 20 mA- / HART output, passive

Configuring the digital outputs

In the case of the device version suited for operation in Ex Zone 1 (dual-compartment housing), digital outputs DO1 (41 / 42) and DO2 (51 / 52) can be configured for connection to a NAMUR switching amplifier.

On leaving the factory, the device is configured with the standard wiring (non-NAMUR).

Connecting the signal cable

Only for remote mount design. The sensor housing and transmitter housing must be connected to potential equalization.

Terminal	Function / comments
U _{FE}	Sensor power supply
GND	Ground
A	Data line
B	Data line
	Functional earth / Shielding

The output circuits are designed so that they can be connected to both intrinsically-safe and non-intrinsically-safe circuits.

- Combining intrinsically safe and non-intrinsically safe circuits is not permitted.
- On intrinsically safe circuits, potential equalization should be established along the entire length of the cable used for the signal outputs.
- The rated voltage of the non-intrinsically safe circuits is U_M = 30 V.
- Intrinsic safety is preserved if the rated voltage U_M = 30 V is not up-scaled when connections are established to non-intrinsically safe external circuits.

Electric data for operation in Zone 1, 21 / Div 1

Devices with HART protocol

When operating in potentially explosive areas, observe the following electrical data for the signal inputs and outputs of the transmitter.

Current output terminals 31 / 32 / U_{co} can be operated on-site in active or passive mode through appropriate switching.

Model: FEP631, FEH631 or FET632	Type of protection													
	'e' / 'XP'		'ia' / 'IS'											
	U _M [V]	I _M [A]	U _O	U _I [V]	I _O [mA]	I _I [mA]	P _O [mW]	P _I [mW]	C _O [nF]	C _I [nF]	C _{OPA} [nF]	C _{IPA} [nF]	L _O [mH]	L _I [mH]
Current / HART output 31 / U _{co} , active Terminals 31 / U _{co}	30	0.2	30	30	115	115	815	815	10	10	5	5	0.08	0.08
Current / HART output 31 / 32, passive Terminals 31 / 32	30	0.2	—	30	—	115	—	815	—	27	—	5	0.08	0.08
Digital output 41 / 42, active* Terminals 41 / 42 and V1 / V2*	30	0.1	27.8	30	119	30	826	225	20	20	29	29	0.22	0.22
Digital output 41 / 42, passive Terminals 41 / 42	30	0.1	—	30	—	30	—	225	—	27	—	5	—	0.08
Digital output 51 / 52, active* Terminals 51 / 52 and V1 / V2*	30	0.1	27.8	30	119	30	826	225	20	20	29	29	0.22	0.22
Digital output 51 / 52, passive Terminals 51 / 52	30	0.1	—	30	—	30	—	225	—	27	—	5	—	0.08

All outputs are electrically isolated from each other and from the power supply.

Digital outputs 41 / 42 and 51 / 52 are not electrically isolated from each other. Terminals 42 / 52 have the same potential.

...Operation in Zone 1, 21 / Div 1

...Electric data for operation in Zone 1, 21 / Div 1

Inputs and outputs with optional plug-in cards	Type of protection														
	'e' / 'XP'		'ia' / 'IS'												
	U _M [V]	I _M [A]	U _O	U _I [V]	I _O [mA]	I _I [mA]	P _O [mW]	P _I [mW]	C _O [nF]	C _I [nF]	C _{OPA} [nF]	C _{IPA} [nF]	L _O [mH]	L _I [mH]	
Current output V3 / V4, active*	30	0.1	27.8	30	119	30	826	225	29	29	117	117	0.4	0.4	
Terminals V3 / V4 and V1 / V2*															
Current output V1 / V2, passive**			—	30	—	68	—	510	—	45	—	59	—	0.27	
Current output V3 / V4, passive**	30	0.1													
Terminals V1 / V2** or V3 / V4**															
Digital output V3 / V4, active*	30	0.1	27.8	30	119	68	826	225	17	17	31	31	0.4	0.4	
Terminals V3 / V4 and V1 / V2*															
Digital output V1 / V2, passive**			—	30	—	30	—	225	—	13	—	16	—	0.27	
Digital output V3 / V4, passive**	30	0.1													
Terminals V1 / V2** or V3 / V4**															
Digital input V3 / V4, active*	30	0.1	27.8	30	119	3.45	826	25.8	17	17	31	31	0.4	0.4	
Terminals V3 / V4 and V1 / V2															
Digital input V1 / V2, passive*			—	30	—	3.45	—	25.8	—	13	—	16	—	0.27	
Digital input V3 / V4, passive*	30	0.1													
Terminals V1 / V2** or V3 / V4**															
Modbus* / PROFIBUS DP*	30	0.1	4.2	4.2	150	150	150	150	1.5	1.5	6	6	0.14	0.14	
Terminals V1 / V2															

* Only in conjunction with additional '24 V DC loop power supply (blue)' plug-in card in slot OC1.

** The terminal assignment depends on the model number or the slot assignments. For connection examples, refer to [Installation in the Operating Instruction \(OI/FEP630/FEH630-EN\)](#).

Temperature data (surface temperature) for operation in Zone 1, 21 / Div 1
Measuring medium temperature (Ex Data) for ProcessMaster Model FEP631



Nominal diameter	Design	Temperature class	Ambient temperature (-40 °C)* -20 °C to +40 °C thermally uninsulated, thermally insulated	Ambient temperature (-40 °C)* -20 °C to +50 °C thermally uninsulated, thermally insulated	Ambient temperature (-40 °C)* -20 °C to +60 °C thermally uninsulated, thermally insulated
			Gas & dust	Gas & dust	Gas & dust
DN3-2000	NT	T1	130 °C	130 °C	130 °C
	HT		180 °C	180 °C	180 °C
	NT	T2	130 °C	130 °C	130 °C
	HT		180 °C	180 °C	180 °C
	NT	T3	130 °C	130 °C	130 °C
	HT		180 °C	180 °C	180 °C
	NT	T4	130 °C	130 °C	130 °C
	HT		130 °C	130 °C	130 °C
	NT	T5	95 °C	95 °C	95 °C
	HT		95 °C	95 °C	95 °C
	NT	T6	80 °C	80 °C	80 °C
	HT		80 °C	80 °C	80 °C

* Low-temperature version (option)

NT standard version, T_{medium} maximum 130 °C (266 °F)

HT high-temperature version, T_{medium} maximum 180 °C (356 °F)

Thermally uninsulated: the sensor is not enclosed with pipe insulation material.

Thermally insulated: the sensor is enclosed with pipe insulation material.

Note

Cables for power supply, signal inputs and outputs must meet the following specifications:

- At an ambient temperature ≤ 50 °C the cable must be suited for at least 60 °C
- At an ambient temperature ≤ 60 °C the cable must be suited for at least 70 °C

...Operation in Zone 1, 21 / Div 1

Temperature data surface temperature for operation in Zone 1, 21 / Div 1

Measuring medium temperature (Ex Data) for ProcessMaster Model FEP632



Nominal diameter	Design	Temperature class	Ambient temperature (-40 °C)* -20 °C to +40 °C thermally uninsulated, thermally insulated	Ambient temperature (-40 °C)* -20 °C to +50 °C thermally uninsulated, thermally insulated	Ambient temperature (-40 °C)* -20 °C to +60 °C thermally uninsulated, thermally insulated
			Gas & dust	Gas & dust	Gas & dust
DN3-2000	NT	T1	130 °C	130 °C	130 °C
	HT		180 °C	180 °C	180 °C
	NT	T2	130 °C	130 °C	130 °C
	HT		180 °C	180 °C	180 °C
	NT	T3	130 °C	130 °C	130 °C
	HT		180 °C	180 °C	180 °C
	NT	T4	130 °C	130 °C	130 °C
	HT		130 °C	130 °C	130 °C
	NT	T5	95 °C	95 °C	95 °C
	HT		95 °C	95 °C	95 °C
	NT	T6	80 °C	80 °C	80 °C
	HT		80 °C	80 °C	80 °C

* Low-temperature version (option)

NT standard version, T_{medium} maximum 130 °C (266 °F)

HT high-temperature version, T_{medium} maximum 180 °C (356 °F)

Thermally uninsulated: the sensor is not enclosed with pipe insulation material.

Thermally insulated: the sensor is enclosed with pipe insulation material.

Note

Cables for power supply, signal inputs and outputs must meet the following specifications:

- At an ambient temperature ≤ 50 °C the cable must be suited for at least 70 °C
- At an ambient temperature ≤ 60 °C the cable must be suited for at least 80 °C

Electrical connections, devices in Zone 2, 22 / Div 2

Electrical connections

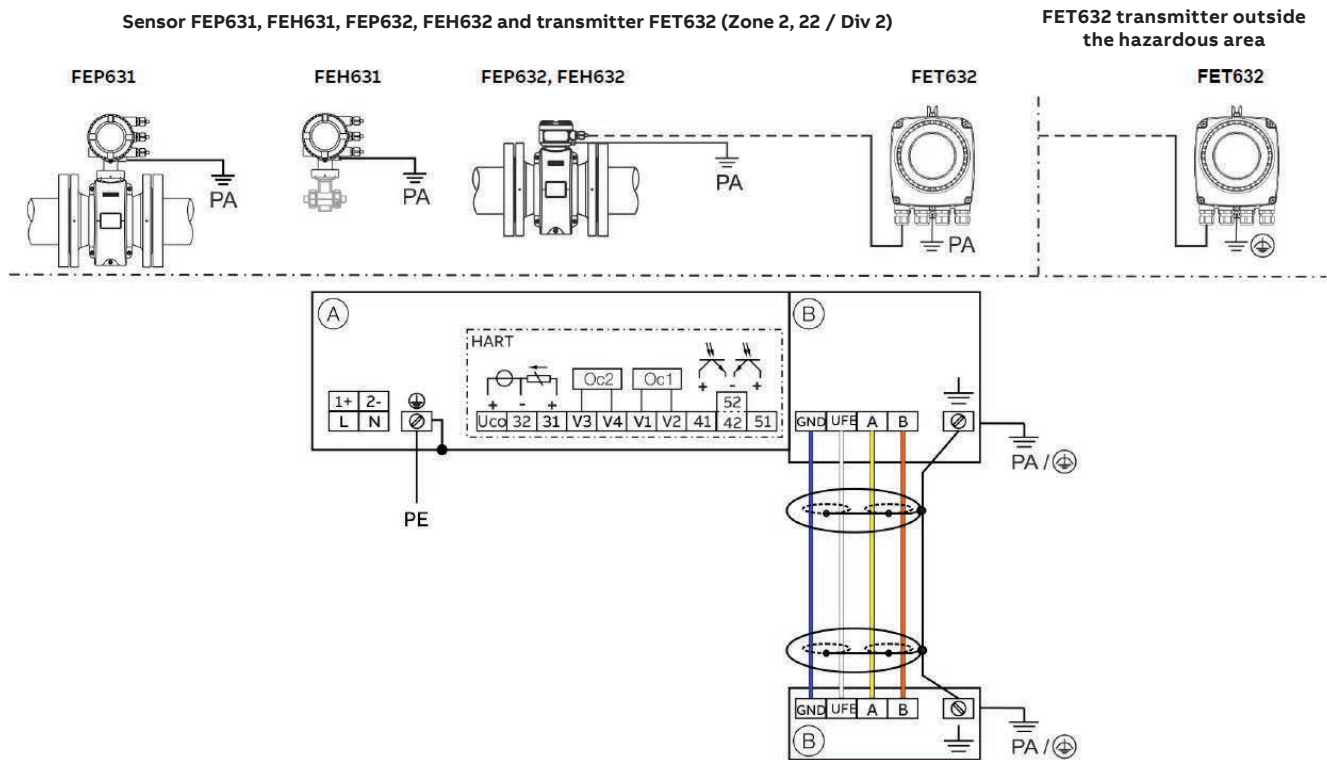

Ⓐ Transmitter

Figure 56 Electrical connections

Note

For detailed information on grounding the transmitter and the sensor, please refer to the operating or commissioning instruction.

Connections for the power supply

AC power supply	
Terminal	Function / comments
L	Phase
N	Neutral conductor
PE / ⊕	Protective earth (PE)
PA	Potential equalization

DC voltage supply	
Terminal	Function / comments
1+	+
2-	-
PE / ⊕	Protective earth (PE)
PA	Potential equalization

Connections for inputs and outputs

Terminal	Function / comments
Uco / 32	Current output 4 to 20 mA- / HART output, active or
31 / 32	Current output 4 to 20 mA- / HART output, passive
41 / 42	Passive digital output DO1
51 / 52	Passive digital output DO2
V1 / V2	Plug-in card, slot OC1
V3 / V4	Plug-in card, slot OC2

Plug-in cards may not be retrofitted in devices with explosion protection on-site – loss of Ex Approval.

Ⓑ Sensor

Connecting the signal cable

Only for remote mount design. The sensor housing and transmitter housing must be connected to potential equalization.

Terminal	Function / comments
U _{FE}	Sensor power supply
GND	Ground
A	Data line
B	Data line
⊥	Functional earth / Shielding

Special connection conditions

Note

The AS plug-in card (24 V DC loop power supply) may only be used to power the internal inputs and outputs on the device. It must not be used to power external circuits!

Note

If the protective earth (PE) is connected in the flowmeter's terminal box, you must ensure that no dangerous potential difference can arise between the protective earth (PE) and the potential equalization (PA) in areas with explosion risk.

Note

For devices with a power supply of 16 to 30 V DC, on-site external overvoltage protection must be provided. It must be ensured that the overvoltage is limited to 140 % (=42 V DC) of the maximum operating voltage.

Operation in Zone 2, 22 / Div 2

Electric data for operation in Zone 2, 22 / Div 2

Devices with HART protocol

When operating in potentially explosive areas, observe the following electrical data for the signal inputs and outputs of the transmitter.

Current output terminals 31 / 32 / Uco can be operated on-site in active or passive mode through appropriate switching.

Model: FEP631, FEH631 or FET632 Outputs on basic device	Operating values (general)		Type of protection – 'nA' / 'NI'	
	U _N	I _N	U _N	I _N
Current / HART output 31 / UCO, active Terminals 31 / UCO	30 V	30 mA	30 V	30 mA
Current / HART output 31 / 32, passive Terminals 31 / 32	30 V	30 mA	30 V	30 mA
Digital output 41 / 42, active* Terminals 41 / 42 and V1 / V2*	30 V	30 mA	30 V	30 mA
Digital output 41 / 42, passive Terminals 41 / 42	30 V	25 mA	30 V	25 mA
Digital output 51 / 52, active* Terminals 51 / 52 and V1 / V2*	30 V	30 mA	30 V	30 mA
Digital output 51 / 52, passive Terminals 51 / 52	30 V	30 mA	30 V	30 mA

All outputs are electrically isolated from each other and from the power supply.

Digital outputs 41 / 42 and 51 / 52 are not electrically isolated from each other. Terminals 42 / 52 have the same potential.

Model: FEP631, FEH631 or FET632 Plug-in cards	Operating values (general)		Type of protection – 'nA' / 'NI'	
	U _N	I _N	U _N	I _N
Current output V3 / V4, active1) Terminals V3 / V4 and V1 / V21)	30 V	30 mA	30 V	30 mA
Current output V1 / V2, passive2) Current output V3 / V4, passive2) Terminals V1 / V22) or V3 / V42)	30 V	30 mA	30 V	30 mA
Digital output V3 / V4, active1) Terminals V3 / V4 and V1 / V21)	30 V	25 mA	30 V	25 mA
Digital output V1 / V2, passive2) Digital output V3 / V4, passive2) Terminals V1 / V22) or V3 / V42)	30 V	30 mA	30 V	30 mA
Digital input V3 / V4, active1) Terminals V3 / V4 and V1 / V2	30 V	3.45 mA	30 V	3.45 mA
Modbus card (RTU)* Terminals V1 / V2	30 V	30 mA	30 V	30 mA
PROFIBUS DP card* Terminals V1 / V2	30 V	30 mA	30 V	30 mA
Ethernet card (Ethernet IP, Modbus TCP) Port 1 / Port 2	57 V	417 mA	57 V	417 mA
Ethernet card in conjunction with power over Ethernet (POE card) (Ethernet IP, Modbus TCP) Port 1 / Port 2	57 V	417 mA	57 V	417 mA

* Only in conjunction with additional '24 V DC loop power supply (blue)' plug-in card in slot OC1.

** The terminal assignment depends on the model number or the slot assignments. For connection examples, refer to **Installation** in the Operating Instruction ([OI/FEP630/FEH630-EN](#)).

Temperature data surface temperature for operation in Zone 2, 22 / Div 2
Measuring medium temperature (Ex Data) for ProcessMaster Model FEP631



Nominal diameter	Design	Temperature class	Ambient temperature (-40 °C)* -20 °C to +40 °C	Ambient temperature (-40 °C)* -20 °C to +50 °C	Ambient temperature (-40 °C)* -20 °C to +60 °C
			thermally uninsulated, thermally insulated	thermally uninsulated, thermally insulated	thermally uninsulated, thermally insulated
			Gas & dust	Gas & dust	Gas & dust
DN3 -2000	NT	T1	130 °C	130 °C	130 °C
	HT		180 °C	180 °C	180 °C
	NT	T2	130 °C	130 °C	130 °C
	HT		180 °C	180 °C	180 °C
	NT	T3	130 °C	130 °C	130 °C
	HT		180 °C	180 °C	180 °C
	NT	T4	130 °C	130 °C	130 °C
	HT		130 °C	130 °C	130 °C
	NT	T5	95 °C	95 °C	40 °C** _***
	HT		95 °C	95 °C	-
	NT	T6	80 °C	-	-
	HT		80 °C	-	-

* Low-temperature version (option)
 ** Single-compartment housing
 *** Dual-compartment housing

NT standard version, T_{medium} maximum 130 °C (266 °F)
 HT high-temperature version, T_{medium} maximum 180 °C (356 °F)
 Thermally uninsulated: the sensor is not enclosed with pipe insulation material.
 Thermally insulated: the sensor is enclosed with pipe insulation material.

Note

Cables for power supply, signal inputs and outputs must meet the following specifications:

With single-compartment housing:

- At an ambient temperature ≤ 50 °C the cable must be suited for at least 80 °C
- At an ambient temperature ≤ 60 °C the cable must be suited for at least 90 °C

With dual-compartment housing:

- At an ambient temperature of 50 °C the cable must be suited for at least 70 °C
- At an ambient temperature of 60 °C the cable must be suited for at least 80 °C

...Operation in Zone 2, 22 / Div 2

Temperature data (surface temperature) for operation in Zone 2, 22 / Div 2

Measuring medium temperature (Ex Data) for ProcessMaster Model FEP632



Nominal diameter	Design	Temperature class	Ambient temperature (-40 °C)* -20 °C to +40 °C thermally uninsulated, thermally insulated	Ambient temperature (-40 °C)* -20 °C to +50 °C thermally uninsulated, thermally insulated	Ambient temperature (-40 °C)* -20 °C to +60 °C thermally uninsulated, thermally insulated
			Gas & dust	Gas & dust	Gas & dust
DN3-2000	NT	T1	130 °C	130 °C	130 °C
	HT		180 °C	180 °C	180 °C
	NT	T2	130 °C	130 °C	130 °C
	HT		180 °C	180 °C	180 °C
	NT	T3	130 °C	130 °C	130 °C
	HT		180 °C	180 °C	180 °C
	NT	T4	130 °C	130 °C	130 °C
	HT		130 °C	130 °C	130 °C
	NT	T5	95 °C	95 °C	95 °C
	HT		95 °C	95 °C	95 °C
	NT	T6	80 °C	80 °C	40 °C
	HT		80 °C	80 °C	20 °C

* Low-temperature version (option)

NT standard version, T_{medium} maximum 130 °C (266 °F)

HT high-temperature version, T_{medium} maximum 180 °C (356 °F)

Thermally uninsulated: the sensor is not enclosed with pipe insulation material.

Thermally insulated: the sensor is enclosed with pipe insulation material.

Note

Cables for power supply, signal inputs and outputs must meet the following specifications:

- At an ambient temperature ≤ 50 °C the cable must be suited for at least 70 °C
- At an ambient temperature ≤ 60 °C the cable must be suited for at least 80 °C

Use in areas exposed to combustible dust

When using the device in areas exposed to combustible dusts (dust ignition), the following points must be observed:

- The maximum surface temperature of the device may not up-scale the following values.

FEP631, FEH631	80 °C (176 °F)
FEP632, FEH632	80 °C (176 °F)
FET632	80 °C (176 °F)
- The process temperature of the attached piping may up-scale 80 °C (176 °F).
- Approved dust-proof cable glands must be used when operating in Zone 21, 22 or in Class II, Class III.
- In potentially explosive atmospheres, the signal cable must measure at least 5 m (16.40 ft).

Ordering Information

ProcessMaster FEP631

Electromagnetic Flowmeter system, integral mount

	ProcessMaster FEP631	7,8	9,10	11,12,13,14	... 80,86
Explosion Protection Certification					
Without		Y0			
ATEX / IECEx (Zone 1 / 21)	1)	A1			
ATEX / IECEx (Zone 2 / 22)		A2			
cFMus Class 1 Div. 1 (Zone 1 / 21)) 30)	1, 32)	F1			
cFMus Class 1 Div. 2 (Zone 2 / 22)		F2			
NEPSI (Zone 1)	1)	S1			
NEPSI (Zone 2)		S2			
Housing Type / Housing Material / Thread for Cable Glands					
Single compartment / Aluminium / M20 x 1.5		4)	S1		
Single compartment / Aluminium / NPT 1/2 in.		4)	S2		
Dual compartment / Aluminium / M20 x 1.5		3)	D1		
Dual compartment / Aluminium / NPT 1/2 in.		3)	D2		
Meter size					
DN 3 (1/10 in.)				0003	
DN 4 (5/32 in.)				0004	
DN 6 (1/4 in.)				0006	
DN 8 (5/16 in.)				0008	
DN 10 (3/8 in.)				0010	
DN 15 (1/2 in.)				0015	
DN 20 (3/4 in.)				0020	
DN 25 (1 in.)				0025	
DN 32 (1-1/4 in.)				0032	
DN 40 (1-1/2 in.)				0040	
DN 50 (2 in.)				0050	
DN 65 (2-1/2 in.)				0065	
DN 80 (3 in.)				0080	
DN 100 (4 in.)				0100	
DN 125 (5 in.)				0125	
DN 150 (6 in.)				0150	
DN 200 (8 in.)				0200	
DN 250 (10 in.)				0250	
DN 300 (12 in.)				0300	
DN 350 (14 in.)				0350	
DN 400 (16 in.)				0400	
DN 450 (18 in.)				0450	
DN 500 (20 in.)				0500	
DN 600 (24 in.)				0600	
DN 700 (28 in.)				0700	
DN 750 (30 in.)				0750	
DN 800 (32 in.)				0800	
DN 900 (36 in.)				0900	
DN 1000 (40 in.)				1000	
DN 1050 (42 in.)				1050	

Continued on next page

ProcessMaster FEP631	7,8	...	11,12,13,14	15,16	17,18	19	20	...	80,86
Meter size (continuation)									
DN 1100 (44 in.)			1100						
DN 1200 (48 in.)			1200						
DN 1400 (54 in.)			1400						
DN 1500 (60 in.)			1500						
DN 1600 (66 in.)			1600						
DN 1800 (72 in.)			1800						
DN 2000 (80 in.)			2000						
Process Connection Type									
Flanges DIN PN 6				7)	D0				
Flanges DIN PN 10					D1				
Flanges DIN PN 16					D2				
Flanges DIN PN 25					D3				
Flanges DIN PN 40					D4				
Flanges DIN PN 63				6)	D5				
Flanges DIN PN 100				6)	D6				
Flansch ASME CL 150; B16.5 up to DN 600, B16.47 series B > DN 600				5)	A1				
Flansch ASME CL 300; B16.5 up to DN 600, B16.47 series B > DN 600				5)	A3				
Flansch ASME CL 600 RF				6a)	A6				
Flange ASME CL 900 RF				6a)	A7				
Flange ASME CL 1500 RF				6b)	A8				
Flange ASME CL 2500 RF				6b)	A9				
Flange ASME CL 600 RTJ				6b)	H6				
Flange ASME CL 900 RTJ				6b)	H7				
Flange ASME CL 1500 RTJ				6b)	H8				
Flange ASME CL 2500 RTJ				6b)	H9				
Flanges JIS 5K					J2				
Flanges JIS 7,5K				2)	J0				
Flanges JIS 10K					J1				
Flanges JIS 20K					J3				
AS 4087 PN16				2)	E1				
Flange, AS2129 table E				2)	E4				
Flange, AS2129 table D				2)	E5				
Liner Material									
Hard rubber					11)	R2			
Soft rubber					12)	R4			
ETFE					9)	E1			
PTFE					13)	T1			
PFA					10)	P1			
Thick PTFE					14)	T2			
Ceramic-Carbide					8)	C1			
Linatex					2)	R6			
Others						Z9			
Process Connection Material									
Carbon steel								B	
Stainless steel						15)		C	
Others								Z	
Electrode Design									
Standard									1
Pointed head							16)		5
Others									9

Continued on next page

...Ordering Information

...ProcessMaster FEP631

ProcessMaster FEP631	7,8	...	21	22	23	24,25	26	27	28,29	30	...	80,86
Measuring Electrodes Material												
Hast. C-4 (2.4610)			D									
Titanium			F									
Tantalum			G									
Hast. B-3 (2.4600)			H									
Platinum-Iridium			J									
Stainless steel 316Ti (1.4571)			S									
Double Layer		16)	W									
Tungsten Carbide, coated			T									
Others			Z									
Grounding Electrode / Full Pipe Detection												
No grounding electrode / No full pipe detection				0								
No grounding electrode / With full pipe detection			17)	1								
Grounding electrode / No full pipe detection			18)	2								
Grounding electrode / With full pipe detection			19)	3								
Others				9								
Grounding Accessories												
Without					A							
Grounding ring (1 off), mounted to flange				20)	B							
Grounding ring (2 off), mounted to flange				20)	C							
Others					Z							
Protection Class Transmitter / Protection Class Sensor												
IP 67 / IP 67						70						
Power Supply												
100 ... 230 V AC, 50 Hz							A					
24 V DC, 50 Hz							D					
100 ... 230 V AC, 60 Hz							C					
24 V DC, 60 Hz							E					
Display												
Without								0				
Display with Keypad								2				
Outputs												
1 Current output (active or passive). 2 Digital Outputs (passive). HART								21)	G0			
Current output 1 (active), digital output 1 & 2 (passive). HART. MODBUS RTU								34)	M1			
Current output 1 (active). digital output 1 & 2 (passive). HART. PROFIBUS DP								35)	D1			
Current output 1 (active or passive), digital output 1 & 2 (passive). HART. 1 port Ethernet								36)	E2			
Current output 1 (active or passive), digital output 1 & 2 (passive). HART. 2 port Ethernet								36)	E3			
Current output 1 (active or passive), digital output 1 & 2 (passive). HART. 1 port Ethernet + POE								36)	E4			
Design Level												
Specified by ABB										22)	A	

Continued on next page

ProcessMaster FEP631	7,8	...	31,32,33	34,35,36	37,38	39, 40, 41	42,43,44	45,46	47,48	49,50	51,52,53	54,55,56	...	80,86
Option Card 1														
Without			DR0											
1 x Digital Input			DRN											
1 x Digital Output			DRG											
24 V DC transmitter loop power supply			DRT											
1 x Analog Output passive (4...20mA)			DRA											
Modbus RTU			DRM											
Profibus DP			DRD											
Card for Ethernet IP, Modbus TCP		37)	DR6											
Option Card 2														
Without				DS0										
1 x Analog Output passive (4...20mA)				DSA										
1 x Digital Input				DSN										
1 x Digital Output				DSG										
Module Power over Ethernet/Modbus TCP (for Single Comp Hsg)		38)		DS8										
Usage Certifications														
Without					C0									
Inspection certificate 3.1 acc. EN 10204					C2									
Others					CZ									
SIL Certificate														
SIL2 Certificate						33)	CS							
Shipping Register Certificate														
Marine approval (DNA)						33)	CL5							
Calibration Certifications														
ABB Standard							CMA							
3rd party witnessed calibration							CMW							
5-point calibration acc. ISO17025						23)	CMD							
Other Usage Certifications														
Meter tube with PED certificate							CRP							
Meter tube without PED certificate						2)	CRA							
Sensor Length														
ABB Standard								J6						
1,0 x DN length (from DN700 and up)							30)	JH						
Other Options														
Without									K0					
With Gore-tex membrane								31)	KG					
Documentation Language														
German										M1				
English										M5				
Chinese										M6				
Ruussian										MB				
Language package Western Europe / Scandinavia										MW				
Language package Eastern Europe										ME				
Others										MZ				
Pressure Bearing Parts Material Source														
Standard												MS0		
Tests and Reports														
Without														CR0
Pressure test acc. to DIN														CPD

Continued on next page

...Ordering Information

...ProcessMaster FEP631

ProcessMaster FEP631	7,8	...	57,58,59	60,61,62	63,64,65	66,67,68	69,70,71	72,73	74,75,76	77,78,79	80,81	82,83,84	85,86
Sensorhousing Material													
Standard			SMA										
Configuration Type													
Parameters set to factory defaults				NC1									
Parameters set customer specific				NCC									
Transmitter Software Function Package													
Standard					NFS								
Enhanced diagnostics					NFE								
Batch Functionality					NFB								
Calibration Type													
0,4% Factory Calibration					25)	RCD							
0,3% Factory Calibration (Option)					26)	RCE							
0,2% Factory Calibration (Option)					24)	RCB							
Signal Cable													
Without							SC0						
Device Identification Plate													
Adhesive label								TC					
Stainless steel								T1					
Stainless steel and TAG plate (stainless steel)								TS					
Others								TZ					
Temperature Range of Installation / Ambient Temperature Range													
Standard Sensordesign / -20 ... 60 °C (-4 ... 140 °F)								27)	TK1				
Standard Sensordesign / -40 ... 60 °C (-40 ... 140 °F)								27)	TK4				
High temperature Sensordesign / -20 ... 60 °C (-4 ... 140 °F)								28)	TKH				
High temperature Sensordesign / -40 ... 60 °C (-40 ... 140 °F)								28)	TKK				
Number of Testpoints													
2 Points									29)	TV2			
3 Points									29)	TV3			
5 Points										TV5			
Verification capability													
Disabled												V0	
Enabled												V1	
Communication options activated													
Ethernet IP													GCE
Modbus TCP													GCM
Websserver													GCW
Profinet											40)		GCP
Connector type													
Without													U0
1 X M 12 Plug for Ethernet 1 Port (4 signal leads)												39)	UE
2 X M 12 Plug for Ethernet 2 Port (4 signal leads)												39)	UF
1 X M 12 Plug for Ethernet 1 Port (8 signal leads)												39)	UG
1 x RJ45 connector with 5 m (15 ft) cable length fitted (4 signal leads)												39)	U5
2 x RJ45 connector with 5 m (15 ft) cable length fitted (4 signal leads)												39)	UB
1 x RJ45 connector with 5 m (15 ft) cable lenth fitted (8 signal leads)												39)	UC
1 x RJ45 connector with 10 m (30 ft) cable length fitted (4 signal leads)												39)	U6
2 x RJ45 connector with 10 m (30 ft) cable length fitted (4 signal leads)												39)	DU
1 x RJ45 connector with 10 m 30 ft cable lenth fitted (8 signal leads)												39)	UH
1 x RJ45 connector with 15 m (49 ft) cable length fitted (4 signal leads)												39)	U7
2 x RJ45 connector with 15 m (49 ft) cable length fitted (4 signal leads)												39)	UJ
1 x RJ45 connector with 15 m 49 ft cable lenth fitted (8 signal leads)												39)	UK
1 x RJ45 connector with 20 m (66 ft) cable length fitted (4 signal leads)												39)	U8
2 x RJ45 connector with 20 m (66 ft) cable length fitted (4 signal leads)												39)	UN
1 x RJ45 connector with 20 m (66 ft) cable length fitted (8 signal leads)												39)	UP

Notes for ProcessMaster FEP631

- 1) Not available with Single Compartment Housing
- 2) For China production site only.
- 3) Not available with Div1 in conjunction with -40°C
- 4) Not available with Zone 1 / Div 1
- 5) Flange DN 15 ... 600 according to ASME B16.5. Flange > DN 600 according to ASME 16.47 Serie B.
- 6) DN 25 ... DN 200 (1 ... 8 in.) Hard Rubber
- 6a) Available from DN25-400 with Hardrubber or ETFE
- 6b) Upon Request
- 7) Available from DN 1000 (40 in.)
- 8) Available from DN25-1000. With Tungsten-Carbide electrode only
- 9) Available from DN25-1000
- 10) Available from DN3-200
- 11) Available from DN25
- 12) Available from DN50
- 13) Available from DN10-600
- 14) Available from DN25-300
- 15) Material: Refer to data sheet. Available with Design Level A
- 16) Available from DN10-400
- 17) TFE Electrode for detection of partial filling, available from DN 50 (2 in.)
- 18) Grounding electrodes, material same as measuring electrodes material
- 19) Grounding electrodes, material same as measuring electrodes material TFE Electrode for detection of partial filling, available from DN 50 (2 in.)
- 20) Available with sensor size <= DN 600 (24 in.) and PTFE / Thick-PTFE / ETFE / PFA liner material. For material, refer to data sheet
- 21) Current output (active or passive) can be configured on site
- 22) Will be specified by ABB
- 23) Available with 5points Calibration
- 24) Not available with size DN 3-8 and > DN900. 0,2% calibration assumes 3 calibration points. If more than 3 calibration points are required, specify 5 points under 'Number of test points'.
- 25) 2 points calibration is Standard. If more than 2 test points are required, please specify 3 or 5 points with option 'Number of Test points'. Accuracy = 0.4 % of rate with size > DN 3
- 26) 3 or 5 test points to be specified
- 27) Maximum fluid temperature with standard sensor design:
 - 130 °C (266 °F) with PTFE, PFA, ETFE
 - 80 °C (194 °F / 176 °F) with hard rubber
 - 60 °C (140 °F) with soft rubber
- 28) Max. fluid temperature with high temperature sensor design:
 - 180 °C (356 °F) with PFA, Thick PTFE.
 - 130 °C (266 °F) with ETFE, PTFE liners.
 - Thick PTFE available for sensor size DN 25 ... DN 300. PFA available for sensor size DN 10 ... DN 200
- 29) Not available with calibration acc to ISO17025
- 30) Available from DN700 and up from China production site
- 31) Not available with Ex
- 32) Available up to DN300 (12")
- 33) Available with Housing Type Code "D1" or "D2"
- 34) To be configured in conjunction with Option Card 1 = Mod bus RTU
- 35) To be configured in conjunction with Option Card 1 = Profibus DP
- 36) To be configured in conjunction with Option Card 1 = Ethernet IP or Modbus TCP
- 36) To be configured in conjunction with Option Card 1 = Ethernet IP or Modbus TCP
- 36) To be configured in conjunction with Option Card 1 = Ethernet IP or Modbus TCP
- 37) Available with single compartment housing only, Non Ex or Zone 2, Div. 2 only
- 38) Available with single compartment housing only and with 24 V power supply unit
- 39) Available with single compartment housing, Ethernet Card, Non-Ex or ATEX Zone 2
- 40) Profinet in preparation

... Ordering Information

ProcessMaster FEP632

Electromagnetic Flowmeter system, remote mount design

	ProcessMaster FEP632	7,8	9,10	11,12,13,14	...	82,83
Explosion Protection Certification						
Without		Y0				
ATEX / IECEx (Zone 1 / 21)		A1				
ATEX / IECEx (Zone 2 / 22)		A2				
cFMus Class 1 Div. 1 (Zone 1 / 21)	32)	F1				
cFMus Class 1 Div. 2 (Zone 2 / 21)		F2				
NEPSI (Zone 1)		S1				
NEPSI (Zone 2)		S2				
Housing Type / Housing Material / Thread for Cable Glands						
Remote / Plastic / M20 x 1.5		31)	P1			
Remote / Plastic / NPT 1/2 in.		31)	P2			
Remote / Aluminum / M20 x 1.5			A1			
Remote / Aluminum / NPT 1/2 in.			A2			
Meter size						
DN 3 (1/10 in.)				0003		
DN 4 (5/32 in.)				0004		
DN 6 (1/4 in.)				0006		
DN 8 (5/16 in.)				0008		
DN 10 (3/8 in.)				0010		
DN 15 (1/2 in.)				0015		
DN 20 (3/4 in.)				0020		
DN 25 (1 in.)				0025		
DN 32 (1-1/4 in.)				0032		
DN 40 (1-1/2 in.)				0040		
DN 50 (2 in.)				0050		
DN 65 (2-1/2 in.)				0065		
DN 80 (3 in.)				0080		
DN 100 (4 in.)				0100		
DN 125 (5 in.)				0125		
DN 150 (6 in.)				0150		
DN 200 (8 in.)				0200		
DN 250 (10 in.)				0250		
DN 300 (12 in.)				0300		
DN 350 (14 in.)				0350		
DN 400 (16 in.)				0400		
DN 450 (18 in.)				0450		
DN 500 (20 in.)				0500		
DN 600 (24 in.)				0600		
DN 700 (28 in.)				0700		
DN 750 (30 in.)				0750		
DN 800 (32 in.)				0800		
DN 900 (36 in.)				0900		
DN 1000 (40 in.)				1000		
DN 1050 (42 in.)				1050		

Continued on next page

ProcessMaster FEP632	7,8	...	11,12,13,14	15,16	17,18	19	20	...	82,83
Meter size (continuation)									
DN 1100 (44 in.)			1100						
DN 1200 (48 in.)			1200						
DN 1400 (54 in.)			1400						
DN 1500 (60 in.)			1500						
DN 1600 (66 in.)			1600						
DN 1800 (72 in.)			1800						
DN 2000 (80 in.)			2000						
Process Connection Type									
Flanges DIN PN 6				4)	D0				
Flanges DIN PN 10					D1				
Flanges DIN PN 16					D2				
Flanges DIN PN 25					D3				
Flanges DIN PN 40					D4				
Flanges DIN PN 63				3)	D5				
Flanges DIN PN 100				3)	D6				
Flansch ASME CL 150; B16.5 up to DN 600, B16.47 series B > DN 600				2)	A1				
Flansch ASME CL 300; B16.5 up to DN 600, B16.47 series B > DN 600				2)	A3				
Flansch ASME CL 600 RF				6a)	A6				
Flange ASME CL 900 RF				6a)	A7				
Flange ASME CL 1500 RF				6b)	A8				
Flange ASME CL 2500 RF				6b)	A9				
Flange ASME CL 600 RTJ				6b)	H6				
Flange ASME CL 900 RTJ				6b)	H7				
Flange ASME CL 1500 RTJ				6b)	H8				
Flange ASME CL 2500 RTJ				6b)	H9				
Flanges JIS 5K					J2				
Flanges JIS 7,5K				2)	J0				
Flanges JIS 10K					J1				
Flanges JIS 20K					J3				
AS 4087 PN16				2)	E1				
Flange, AS2129 table E				2)	E4				
Flange, AS2129 table D				2)	E5				
Liner Material									
Hard rubber				8)	R2				
Soft rubber				9)	R4				
ETFE				6)	E1				
PTFE				10)	T1				
PFA				7)	P1				
Thick PTFE				11)	T2				
Ceramic-Carbide				5)	C1				
Linatex				1)					
Others					Z9				
Process Connection Material									
Carbon steel							B		
Stainless steel						12)	C		
Others							Z		
Electrode Design									
Standard								1	
Pointed head						13)		5	
Others								9	

Continued on next page

... Ordering Information

...ProcessMaster FEP632

ProcessMaster FEP632	7,8	...	21	22	23	24,25	26	27	28,29	30	...	82,83
Measuring Electrodes Material												
Hast. C-4 (2.4610)			D									
Titanium			F									
Tantalum			G									
Hast. B-3 (2.4600)			H									
Platinum-Iridium			J									
Stainless steel 316Ti (1.4571)			S									
Double Layer		13)	W									
Tungsten Carbide, coated			T									
Others			Z									
Grounding Electrode / Full Pipe Detection												
No grounding electrode / No full pipe detection				0								
No grounding electrode / With full pipe detection			14)	1								
Grounding electrode / No full pipe detection			15)	2								
Grounding electrode / With full pipe detection			16)	3								
Others				9								
Grounding Accessories												
Without					A							
Grounding ring (1 off), mounted to flange				17)	B							
Grounding ring (2 off), mounted to flange				17)	C							
Others					Z							
Protection Class Transmitter / Protection Class Sensor												
IP 67 / IP 67						70						
IP 67 / IP 68					18)	76						
IP 67 / IP 68, signal cable fitted and potted					19)	77						
Power Supply												
Without							Y					
Display												
Without								0				
Outputs												
Without										Y0		
Design Level												
Specified by ABB										20)	A	

Continued on next page

ProcessMaster FEP632	7,8	...	31,32,33	34,35,36	37,38	39,40,41	42,43,44	45,46	47,48	49,50	51,52	53,54,55	56,57,58	...	82,83
Option Card 1															
Without			DRO												
Option Card 2															
Without				DSO											
Usage Certifications															
Without															
Inspection certificate 3.1 acc. EN 10204															C0
Others															C2
															CZ
SIL Certificate															
SIL2 Certificate															CS
Shipping Register Certificate															
Marine approval (DNV)															CL5
Calibration Certifications															
ABB Standard															CMA
3rd party witnessed calibration															CMW
5-point calibration acc. ISO17025															21) CMD
Other Usage Certifications															
Meter tube with PED certificate															CRP
Meter tube without PED certificate															1) CRA
Power Supply Line Frequency															
50 Hz															22) F5
60 Hz															23) F6
Sensor Length															
ABB Standard (1,3 x DN)															J6
1,0 x DN length (from DN700 and up)															30) JH
Other Options															
Without															K0
With Gore-tex membrane															31) KG
Documentation Language															
German															M1
English															M5
Chinese															M6
Russian															MB
Language package Western Europe / Scandinavia															MW
Language package Eastern Europe															ME
Others															MZ
Pressure Bearing Parts															
Material Source															
Standard															MS0
Tests and Reports															
Without															CR0
Pressure test acc. to DIN															CPD

Continued on next page

... Ordering Information

... ProcessMaster FEP632

ProcessMaster FEP632	7,8	...	59,60,61	62,63,64	65,66,67	68,69,70	71,72,73	...	82,83
Sensorhousing Material									
Standard			SMA						
Configuration Type									
Parameters set to factory defaults				NC1					
Parameters set customer specific				NCC					
Transmitter Software Function Package									
Standard					NFS				
Enhanced diagnostics					NFE				
Batch Functionality					NFB				
Calibration Type									
0,4% Factory Calibration						25)	RCD		
0,3% Factory Calibration (Option)						26)	RCE		
0,2% Factory Calibration (Option)						24)	RCB		
Signal Cable									
Without								SC0	
5 m (approx. 15 ft)								SC1	
10 m (approx. 30 ft)								SC2	
15 m (approx. 49 ft)								SC3	
20 m (approx. 66 ft)								SC4	
25 m (approx. 82 ft)								SC5	
30 m (approx. 98 ft)								SC6	
35 m (approx. 115 ft)								SC7	
40 m (approx. 131 ft)								SC8	
50 m (approx. 164 ft)								SCA	
60 m (approx. 197 ft)								SCB	
70 m (approx. 230 ft)								SCC	
80 m (approx. 262 ft)								SCD	
100 m (approx. 328 ft)								SCE	
125 m (approx. 410 ft)								SCF	
150 m (approx. 492 ft)								SCG	
175 m (approx. 574 ft)								SCH	
200 m (approx. 656 ft)								SCJ	

Continued on next page

ProcessMaster FEP632	7,8	...	74,75	76,77,78	79,80,81	82,83
Device Identification Plate						
Adhesive label			TC			
Stainless steel			T1			
Stainless steel and TAG plate (stainless steel)			TS			
Others			TZ			
Temperature Range of Installation / Ambient Temperature Range						
Standard Sensordesign / -20... 60 °C (-4 ... 140 °F)			27)	TK1		
Standard Sensordesign / -40 ... 60 °C (-40 ... 140 °F)			27)	TK4		
High temperature Sensordesign / -20... 60 °C (-4 ... 140 °F)			28)	TKH		
High temperature Sensordesign / -40 ... 60 °C (-40 ... 140 °F)			28)	TKK		
Number of Testpoints						
2 Points				29)	TV2	
3 Points				29)	TV3	
5 Points					TV5	
Verification Capability						
Disabled						V0
Enabled						V1

Notes for ProcessMaster FEP632

- 1) For China production site only.
- 2) Flange DN 15 ... 600 according to ASME B16.5. Flange > DN 600 according to ASME 16.47 Serie B.
- 3) DN 25 ... DN 200 (1 ... 8 in.) Hard Rubber
- 4) Available from DN 1000 (40 in.)
- 5) Available from DN25-1000. With Tungsten-Carbide electrode only
- 6) Available from DN25-1000
- 6a) Available from DN25-400 with Hardrubber or ETFE
- 6b) Upon Request
- 7) Available from DN3-200
- 8) Available from DN25
- 9) Available from DN50
- 10) Available from DN10-600
- 11) Available from DN25-300
- 12) Material: Refer to data sheet. Available with Design Level A
- 13) Available from DN10-400
- 14) TFE Electrode for detection of partial filling, available from DN 50 (2 in.)
- 15) Grounding electrodes, material same as measuring electrodes material
- 16) Grounding electrodes, material same as measuring electrodes material TFE Electrode for detection of partial filling, available from DN 50 (2 in.)
- 17) Available with sensor size <= DN 600 (24 in.) and PTFE / Thick-PTFE / ETFE / PFA liner material. For material, refer to data sheet
- 18) Only available with remote transmitter, sealing compound (optional) D141B038U01
- 19) Only available with remote transmitter
- 20) Will be specified by ABB
- 21) Available with 5 points Calibration
- 22) 50 Hz (to be specified in case no Tx is ordered)
- 23) 60 Hz (to be specified in case no Tx is ordered)
- 24) Not available with size DN 3-8 and > DN800. 0,2% calibration assumes 3 calibration points. If more than 3 calibration points are required, specify 5 points under 'Number of test points'.
- 25) 2 points calibration is Standard. If more than 2 testpoints are required, please specify 3 or 5 points with option 'Number of Testpoints'. Accuracy = 0.4 % of rate with size > DN 3
- 26) 3 or 5 testpoints to be specified
- 27) Max. fluid temperature with standard sensor design:
 - 130 °C (266 °F) with PTFE, PFA, ETFE
 - 80 °C (194 °F / 176 °F) with hard rubber
 - 60 °C (140 °F) with soft rubber
- 28) Max. fluid temperature with high temperature sensor design:
 - 180 °C (356 °F) with PFA, Thick PTFE. Thick PTFE available for sensor size DN 25 ... DN 300. PFA available for sensor size DN 10 ... DN 200
 - 130 °C (266 °F) with ETFE, PTFE liners.
- 29) Not available with calibration acc to ISO17025
- 30) Available from DN700 and up from China production site
- 31) Not available with Ex
- 32) Available up to DN300 (12")
- 33) Not available with EX Zone 1, Div 1

...Ordering Information

Remote transmitter FET632

FET632 Electromagnetic Flowmeter, remote transmitter for ProcessMaster FEP630

Remote transmitter FET632	7,8	9,10	11,12	13	14	15,16	17,18,19	20,21,22	...	46,47
Explosion Protection Certification										
Without	Y0									
ATEX / IECEx (Zone 1 / 21)	A1									
ATEX / IECEx (Zone 2 / 22)	A2									
cFMus Class 1 Div. 1 (Zone 1 / 21)	F1									
cFMus Class 1 Div. 2 (Zone 2 / 21)	F2									
NESPI (Zone 1)	S1									
NEPSI (Zone 2)	S2									
Housing Type / Housing Material / Thread for Cable Glands										
Field-mount / Single compartment / Aluminum / 4 x M20 x 1.5	3)	F1								
Field-mount / Single compartment / Aluminum / 4 x NPT 1/2 in.	3)	F2								
Field-mount / Dual compartment / Aluminum / M20 x 1.5	3a)	W1								
Field-mount / Dual compartment / Aluminum / NPT 1/2 in.	3a)	W2								
Protection Class Transmitter / Protection Class Sensor										
IP 67 / IP 67			70							
Power Supply										
100 ... 230 V AC, 50 Hz				A						
24 V DC, 50 Hz				D						
100 ... 230 V AC, 60 Hz				C						
24 V DC, 60 Hz				E						
Display										
Without					0					
Display with Keypad					2					
Outputs										
1 Current output (active or passive), 2 Digital Outputs (passive), HART					4)	G0				
Current output 1 (active), digital output 1 & 2 (passive), HART, MODBUS RTU					7)	M1				
Current output 1 (active). digital output 1 & 2 (passive). HART, PROFIBUS DP					8)	D1				
Current output 1 (active or passive). digital output 1 & 2 (passive). HART, 1 port Ethernet					9)	E2				
Current output 1 (active or passive), digital output 1 & 2 (passive), HART, 2 port Ethernet					9)	E3				
Current output 1 (active or passive), digital output 1 & 2 (passive), HART, 1 port Ethernet + POE					9)	E4				
Option Card 1										
Without								DR0		
1 x Digital Input								DRN		
1 x Digital Output								DRG		
24 V DC transmitter loop power supply								DRT		
1 x Analog Output passive (4 ... 20mA)								DRA		
Modbus RTU								DRM		
Profibus DP								DRD		
Card for Ethernet IP, Modbus TCP						10)		DR6		
Option Card 2										
Without									DS0	
1 x Analog Output passive (4 .. 20mA)									DSA	
1 x Digital Input									DSN	
1 x Digital Output									DSG	
Modul Power over Ethernet / Modbus (for Single Comp Hsg)							11)		DS8	





Continued on next page

Remote transmitter FET632	7,8	...	23,24	25,26	27,28	29,30	31,32	33,34	35,36,37	38,39	40,41,42	43,44,45	46,47
SIL Certificate													
SIL2 Certificate		6)	CS										
Shipping Register Certificate													
Marine approval (DNV)				CL5									
Potable Water and Food & Beverage Approvals													
Without					CWY								
Other Options													
Without													K0
With Gore-tex membrane					5)								KG
Documentation Language													
German													M1
English													M5
Chinese													M6
Russian													MB
Language package Western Europe / Scandinavia													MW
Language package Eastern Europe													ME
Device Identification Plate													
Adhesive label													TC
Stainless steel													T1
Stainless steel and TAG plate (stainless steel)													TS
Others													TZ
Temperature Range of Installation / Ambient Temperature Range													
Standard design / -20... 60 °C (-4 ... 140 °F)													TK1
Standard design / -40 ... 60 °C (-40 ... 140 °F)													TK4
Remote Transmitter Mounting Kit													
Without													B0
2" Pipe Mounting Kit for Field-mount / Dual compartment Housing													B1
2" Pipe Mounting Kit for Field-mount / Single compartment Housing													B2
Transmitter Software Function Package													
Standard													NFS
Communication options activated													
Ethernet IP													GCE
Modbus TCP													GCM
Webserver													GCW
Profinet												13)	GCP
Connector type													
Without													U0
1 X M 12 Plug for Ethernet 1 Port (4 signal leads)												12)	UE
2 X M 12 Plug for Ethernet 2 Port (4 signal leads)												12)	UF
1 X M 12 Plug for Ethernet 1 Port (8 signal leads)												12)	UG
1 x RJ45 connector with 5 m (15 ft) cable length fitted (4 signal leads)												12)	U5
2 x RJ45 connector with 5 m (15 ft) cable length fitted (4 signal leads)												12)	UB
1 x RJ45 connector with 5 m (15 ft) cable length fitted (8 signal leads)												12)	UC
1 x RJ45 connector with 10 m (30 ft) cable length fitted (4 signal leads)												12)	U6
2 x RJ45 connector with 10 m (30 ft) cable length fitted (4 signal leads)												12)	DU
1 x RJ45 connector with 10 m 30 ft cable length fitted (8 signal leads)												12)	UH
1 x RJ45 connector with 15 m (49 ft) cable length fitted (4 signal leads)												12)	U7
2 x RJ45 connector with 15 m (49 ft) cable length fitted (4 signal leads)												12)	UJ
1 x RJ45 connector with 15 m 49 ft cable length fitted (8 signal leads)												12)	UK
1 x RJ45 connector with 20 m (66 ft) cable length fitted (4 signal leads)												12)	U8
2 x RJ45 connector with 20 m (66 ft) cable length fitted (4 signal leads)												12)	UN
1 x RJ45 connector with 20 m (66 ft) cable length fitted (8 signal leads)												12)	UP

1) Not available with Single Compartment Housing
 2) Not available with -40°C. Not available with Single Compartment Housing
 3) Not available with Zone 1 / Div. 1
 3a) Not available with Zone 2 / Div. 2
 4) Current output (active or passive) can be configured on site
 5) Not available with Ex
 6) Available with housing Type Code 'W1' or 'W2'

7) To be configured in conjunction with Option Card 1 = Modbus RTU
 8) To be configured in conjunction with Option Card 1 = Profibus DP
 9) To be configured in conjunction with Option Card 1 = Ethernet IP or Modbus TCP
 10) Available with single compartment housing only, Non Ex or Zone 2, Div. 2 only
 11) Available with single compartment housing only and with 24 V power supply unit
 12) Available with single compartment housing, Ethernet Card, Non-Ex or ATEX Zone 2
 13) Profinet in preparation

Accessories

Description	Order code
Infrared service port adapter FZA100	D674A897U01
	
Installation set for NPT 1/2" cable gland. For sealing the cable conduit during outdoor installation.	3KXF081300L0001*
	
Adapter M20x1.5 to 1/2"NPT	D365B269U01*
	
Data link cable	3KXS360040L0003*
	
Signal cable	
3KQZ407123U0500	5 m (approx. 15 ft)
3KQZ407123U1000	10 m (approx. 30 ft)
3KQZ407123U1500	15 m (approx. 49 ft)
3KQZ407123U2000	20 m (approx. 66 ft)
3KQZ407123U2500	25 m (approx. 82 ft)
3KQZ407123U3000	30 m (approx. 98 ft)
3KQZ407123U3500	35 m (approx. 115 ft)
3KQZ407123U4000	40 m (approx. 131 ft)
3KQZ407123U5000	50 m (approx. 164 ft)
3KQZ407123U8000	80 m (approx. 262 ft)
3KQZ407123U1H00	100 m (approx. 328 ft)
3KQZ407123U1F00	150 m (approx. 492 ft)
3KQZ407123U2H00	200 m (approx. 656 ft)
ABB Ability Verification Tool	SRV500*

*Available from ABB Service

Sales



Service



Trademarks

- © FOUNDATION Fieldbus is a registered trademark of FieldComm Group, Austin, Texas, USA
- © HART is a registered trademark of FieldComm Group, Austin, Texas, USA
- © PROFIBUS and PROFIBUS PA are registered trademarks of PROFIBUS & PROFINET International (PI)
- © LINATEX is a registered trademark of LINATEX Ltd.
- ™ Hastelloy C is a trademark of Haynes International

—
ABB Limited
Measurement & Analytics
Oldends Lane
Stonehouse
Gloucestershire GL10 3TA
UK
Tel: +44 (0)1453 826661
Fax: +44 (0)1453 829671

ABB Automation Products GmbH
Measurement & Analytics
Dransfelder Str. 2
37079 Goettingen
Germany
Tel: +49 551 905-0
Fax: +49 551 905-777
Email: vertrieb.messtechnik-produkte@de.abb.com

ABB Inc.
Measurement & Analytics
125 E. County Line Road
Warminster, PA 18974
USA
Tel: +1 215 674 6000
Fax: +1 215 674 7183

ABB Engineering (Shanghai) Ltd.
Measurement & Analytics
No. 4528, Kangxin Highway, Pudong New District
Shanghai, 201319,
P.R. China
Tel: +86(0) 21 6105 6666
Fax: +86(0) 21 6105 6677
Email: china.instrumentation@cn.abb.com

abb.com/flow

—
We reserve the right to make technical changes or modify the contents of this document without prior notice.
With regard to purchase orders, the agreed particulars shall prevail. ABB does not accept any responsibility whatsoever for potential errors or possible lack of information in this document. We reserve all rights in this document and in the subject matter and illustrations contained therein.
Any reproduction, disclosure to third parties or utilization of its contents – in whole or in parts – is forbidden without prior written consent of ABB.