



Series
3100

Explosion-Proof Differential Pressure Transmitter

HART®, Push Button Configuration, Rangeability (100:1)



Scan here to watch product video



3100D



Scan here to watch product video



3100MP

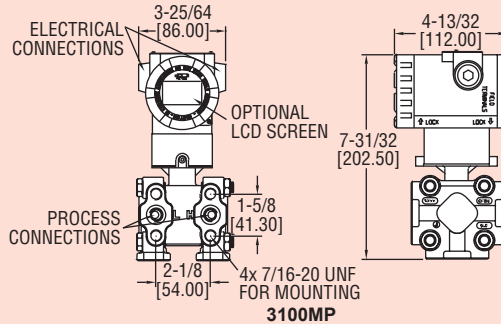
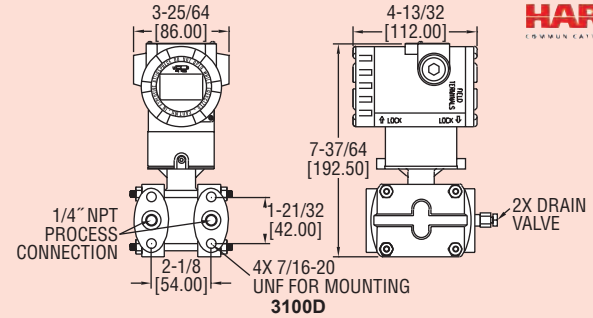

The Mercoïd® Series 3100 Smart Pressure Transmitter is a microprocessor-based high performance transmitter, which has flexible pressure calibration, push button configuration, and programmable using HART® Communication. The Series 3100 is capable of being configured for differential pressure or level applications with the zero and span buttons. A field calibrator is not required for configuration. The transmitter software compensates for thermal effects, improving performance. EEPROM stores configuration settings and stores sensor correction coefficients in the event of shutdowns or power loss. The Series 3100 is FM or ATEX approved for use in hazardous (classified) locations. The 100:1 rangeability allows the smart transmitter to be configured to fit any application.

FEATURES

- Configurable using zero/span buttons (no calibrator required)
- Rangeability (100:1)
- High accuracy (±0.075%)
- Automatic sensor temperature compensation
- Fail-mode process function
- Selectable engineering units

APPLICATIONS

- Flow measurement
- Level monitoring
- Filter or pump differential pressure
- Critical process monitoring

SPECIFICATIONS

Service: Compatible gases, steam, liquids or vapors.
Wetted Materials: 316L SS.
Accuracy: ±0.075% FS (@ 20°C).
Rangeability: 100:1 turn down.
Stability: ±0.125% FSO/yr.
Temperature Limits:
 Process: -40 to 248°F (-40 to 120°C);
 Ambient: Without LCD: -40 to 185°F (-40 to 85°C);
 With LCD: -22 to 176°F (-30 to 80°C).
Pressure Limits: Max. pressure:
 Range: -14.5 to 2000 psi; Burst pressure: 10000 psi.
Thermal Effect: ±0.125% span/32°C.
Power Requirements: 11.9 to 45 VDC.
Output Signal: 4 to 20 mA / HART® Communication.

Response Time: 0.12 seconds.
Damping Time: 0.25 to 60 seconds.
Loop Resistance:
 Operation: 0 to 1500 Ω;
 HART® Communication: 250 to 500 Ω.
Electrical Connection: Two 1/2" female NPT conduit, screw terminal.
Process Connection: 1/4" female NPT.
Display: Optional 5 digit LCD.
Enclosure Rating: NEMA 4X (IP66) and explosion-proof for Class I, Div I, Groups A, B, C and D.
Weight: 8.6 lb (3.9 kg).
Agency Approvals: CE, FM, ATEX option available (consult factory).

Model	Calibrated Span (Min. to Max.)		Lower Range Limit		Upper Range Limit		LCD Display
3100D-2-FM-1-1	0.6 to 30 in w.c.	0.15 to 7.5 kPa	-30 in w.c.	-7.5 kPa	30 in w.c.	7.5 kPa	No
3100D-3-FM-1-1	1.5 to 150 in w.c.	0.373 to 37.3 kPa	-150 in w.c.	-37.3 kPa	150 in w.c.	37.3 kPa	No
3100D-4-FM-1-1	7.5 to 750 in w.c.	1.865 to 186.5 kPa	-750 in w.c.	-186.5 kPa	750 in w.c.	186.5 kPa	No
3100D-5-FM-1-1	1 to 100 psi	6.9 to 690 kPa	-100 psi	-690 kPa	100 psi	690 kPa	No
3100D-6-FM-1-1	3 to 300 psi	20.68 to 2068 kPa	-300 psi	-2068 kPa	300 psi	2068 kPa	No
3100D-2-FM-1-1-LCD	0.6 to 30 in w.c.	0.15 to 7.5 kPa	-30 in w.c.	-7.5 kPa	30 in w.c.	7.5 kPa	Yes
3100D-3-FM-1-1-LCD	1.5 to 150 in w.c.	0.373 to 37.3 kPa	-150 in w.c.	-37.3 kPa	150 in w.c.	37.3 kPa	Yes
3100D-4-FM-1-1-LCD	7.5 to 750 in w.c.	1.865 to 186.5 kPa	-750 in w.c.	-186.5 kPa	750 in w.c.	186.5 kPa	Yes
3100D-5-FM-1-1-LCD	1 to 100 psi	6.9 to 690 kPa	-100 psi	-690 kPa	100 psi	690 kPa	Yes
3100D-6-FM-1-1-LCD	3 to 300 psi	20.68 to 2068 kPa	-300 psi	-2068 kPa	300 psi	2068 kPa	Yes

Consult factory for custom calibration.

Model	Calibrated Span (Min. to Max.)		Lower Range Limit		Upper Range Limit		LCD Display
3100MP-2-FM-1-1	0.6 to 30 in w.c.	0.15 to 7.5 kPa	-30 in w.c.	-7.5 kPa	30 in w.c.	7.5 kPa	No
3100MP-3-FM-1-1	1.5 to 150 in w.c.	0.373 to 37.3 kPa	-150 in w.c.	-37.3 kPa	150 in w.c.	37.3 kPa	No
3100MP-4-FM-1-1	7.5 to 750 in w.c.	1.865 to 186.5 kPa	-750 in w.c.	-186.5 kPa	750 in w.c.	186.5 kPa	No
3100MP-5-FM-1-1	1 to 100 psi	6.9 to 690 kPa	-100 psi	-690 kPa	100 psi	690 kPa	No
3100MP-6-FM-1-1	3 to 300 psi	20.68 to 2068 kPa	-300 psi	-2068 kPa	300 psi	2068 kPa	No
3100MP-2-FM-1-1-LCD	0.6 to 30 in w.c.	0.15 to 7.5 kPa	-30 in w.c.	-7.5 kPa	30 in w.c.	7.5 kPa	Yes
3100MP-3-FM-1-1-LCD	1.5 to 150 in w.c.	0.373 to 37.3 kPa	-150 in w.c.	-37.3 kPa	150 in w.c.	37.3 kPa	Yes
3100MP-4-FM-1-1-LCD	7.5 to 750 in w.c.	1.865 to 186.5 kPa	-750 in w.c.	-186.5 kPa	750 in w.c.	186.5 kPa	Yes
3100MP-5-FM-1-1-LCD	1 to 100 psi	6.9 to 690 kPa	-100 psi	-690 kPa	100 psi	690 kPa	Yes
3100MP-6-FM-1-1-LCD	3 to 300 psi	20.68 to 2068 kPa	-300 psi	-2068 kPa	300 psi	2068 kPa	Yes

Consult factory for custom calibration.

HART® is a registered trademark of Hart Communication Foundation.

Ordering Chart

Example	3100D	2	FM	3	1	LEC	S2	A1	05	S	2	05	10	LCD	3100D-2-FM-3-1-LECS2A105S2-05-10-LCD
Series	3100D 3100MP														3100D Explosion-Proof Differential Pressure Transmitter 3100MP Multiplanar Explosion-Proof Differential Pressure Transmitter
Range		1 2 3 4 5 6 7													0 to 6 in w.c. 0 to 30 in w.c. 0 to 150 in w.c. 0 to 750 in w.c. 0 to 100 psi 0 to 300 psi 0 to 1000 psi
Approval			FM ATEX WP												FM approved ATEX approved NEMA 4X (IP66) [Only available with 316 SS housing]
Process Connection				1 3											1/4" female NPT Diaphragm seal
Electrical Connection				1											1/2" female NPT
Diaphragm Seal Type					LEC LED LEH LEL LFC LFD LFH LFL										2 extended diaphragm seals capillary type 1 extended diaphragm seal direct mount high side 1 extended diaphragm seal capillary type high side 1 extended diaphragm seal capillary type low side 2 flush diaphragm seals capillary type 1 flush diaphragm seal direct mount high side 1 flush diaphragm seal capillary type high side 1 flush diaphragm seal capillary type low side
Mounting Flange							S2 S3								2" (50 mm) 316L SS 3" (80 mm) 316L SS
Mounting Flange Rating								A1 A2 D1 D2 J1 J2							ANSI class 150# ANSI class 300# DIN PN 10/16 DIN PN 25/40 JIS 10 K JIS 20 K
Extension Length									00 05 10 15						No extension [standard for flush mount] 2" extension 4" extension 6" extension
Diaphragm Material										S P H T					316L SS diaphragm PTFE and 316L SS diaphragm Hastelloy C-276 diaphragm Tantalum diaphragm
Fill Fluid											2				Silicon oil (-40 to 400°F)
Capillary Length High Side												XX			0 to 20 feet
Capillary Length Low Side													XX		0 to 20 feet
Options														LCD SSH NIST CC	5 digit LCD 316 SS housing (Only available with WP approval) NIST calibration Custom calibration

Custom Calibration Values

Primary Units	in H ₂ O, ft H ₂ O, mm H ₂ O, in Hg, psig, g/cm ² , kg/cm ² , MPa, Pa, kPa, bar, mbar, Torr, Atm, mm Hg
Upper Range Limit	20 mA value
Lower Range Limit	4 mA value
Output	Linear or square root
Damping Time	0 to 60 seconds
Display Mode	Unit, %, mA, rotate
Display Units	Primary unit or Engineering unit
Engineering Units*	Volumetric Flow Units US gal/s, US gpm, US gal/hr, US gpd, imp gal/s, imp gpm, imp gal/hr, imp gpd, l/s, l/min, l/hour, ft/s, m/s, metric gal/day, metric l/day, ft ³ /s, ft ³ /min, ft ³ /h, ft ³ /day, m ³ /s, m ³ /min, m ³ /hr, m ³ /day, normal l/hr, normal m ³ /hr, standard ft ³ /min, barrels/s, barrels/min, barrels/hr, barrels/day Mass Flow Units g/s, g/min, g/hr, kg/s, kg/min, kg/hr, kg/day, metric ton/min, metric ton/hour, metric ton/day, lb/s, lb/min, lb/hr, lb/day, short ton/min, short ton/hr, short ton/day, long ton/hr, long ton/day Volume Units gallons, liters, imp gallons, m ³ , barrels, bushels, yd ³ , ft ³ , in ³ , bbl liq, normal cubic meter, normal liter, standard cubic feet, hectoliters
Engr. Upper Range Limit*	Engr. upper value
Engr. Lower Range Limit*	Engr. lower value
Engr Function*	Linear or square root

*Engineering Units, Engr. Upper Range Limit, Engr. Lower Range Limit and Engr. Function values are only required if engineering unit is selected.

ACCESSORIES

- A-630**, Stainless steel angle type bracket with SS bolts
- A-631**, Stainless steel flat type bracket with SS bolts
- BBV-1F**, Flanged 3-valve block manifold
- BBV-22F**, Flanged 5-valve block manifold
- DevCom2000**, HART® Communication Protocol Software