



TEX-TOTAL

Flow Rate Totalizer



The TEX-TOTAL rate meter and totalizer is ideal for flow rate monitoring of transmitters and sensors with mA output.

It features dual totalizers with low flow cut-off and roll over, and input signal averaging to stabilise measurement.

The TEX-TOTAL features a 6-digit alphanumeric LED display, with scrolling text prompts that guide you step-by-step through the setup process. The unit is easy to scale to suit your desired time and measurement units.

Order Codes

TEX-TOTAL Flow Rate Totalizer

- HV 85–265V AC / 95–370V DC
- LV 15–48V AC / 10–72V DC

Options

- R2 2 x relay outputs
- R4 4 x relay outputs
- A 1 x mA/V analog output
- S2R 1 x RS232 (RJ11 terminal)
- S4S 1 x RS485 (screw terminal)

Contents

1 - Specifications	2
2 - Front Panel & Display	3
3 - Wiring	5
4 - Dimensions & Installation	8
5 - Input Setup & Calibration	10
6 - Totalizer Reset & Setpoint Setup	16
7 - Setpoint Direct Access	20
8 - Reset PIN Numbers / View Firmware Version	20
A - Appendix A - Serial Modes	21

1

SPECIFICATIONS

Input

Input signal Current (0/4–20mA)

Power supply

HV= 85–265V AC / 95–370V DC, or
LV= 15–48V AC / 10–72V DC

Excitation 24V DC (50mA max)

Sampling rate 10Hz

Resolution 16 bit

Accuracy 0.05% of reading

Ambient drift 50ppm/°C typical

Flow rate /sec, /min or /hour

Flow resolution 1, 0.1, 0.01 or 0.001

Totalizers Dual totalizers

Totalizer resolution x0.1, x1, x10, x100
or x1000

Noise rejection 50/60Hz

Relay Output

OPTIONAL

Number of relay outputs None, 2, or 4

Relay output type 5A form A (3A 240V
AC max or 3A 30V DC max)

Analog Output

OPTIONAL

Analog output (Optional) Isolated 16
bit 4–20mA/0–10V

Comm Port

OPTIONAL

Serial port (Optional) Isolated RS232 or
RS485 (select when placing your order)

Programming

Front panel buttons Up, Down, P
(Prog/Enter), plus 2x Function Buttons
for menu access

Security Input and setpoint setups
are independently accessible and PIN
protected

Display

Display type LED display, 5 buttons

LED indicators 6 setpoint indicator LED's

Digits 1 row of 6 digits, 13mm (0.5"), 14
segment alphanumeric LED

Construction

Casing Panel mount case

Ingress protection rating IP65 dust/
splash proof (face only)

Dimensions (H x W x D)

48 x 96 x 120mm (1.89 x 3.78 x 4.72")

Panel cutout 45 x 92mm (1.77 x 3.62")

2

FRONT PANEL & DISPLAY

2.1 - Front panel

SPX The SP LED's are used to indicate active setpoints.

F1 This button is used to access the **Input Setup & Calibration** menu (Section 5).

P This button is used to save your settings and advance to the next step in the setup process.

↑ This button is typically used to scroll through options or increase values in the setup menu. Pressing this button from the main display will allow you to view/reset the *Peak* value, and view the *Total 1* value (see 2.3).

↓ This button is typically used to scroll through options or decrease values in the setup menu. Pressing this button from the main display will allow you to view/reset the *Valley* value, and view the *Total 2* value (see 2.3).



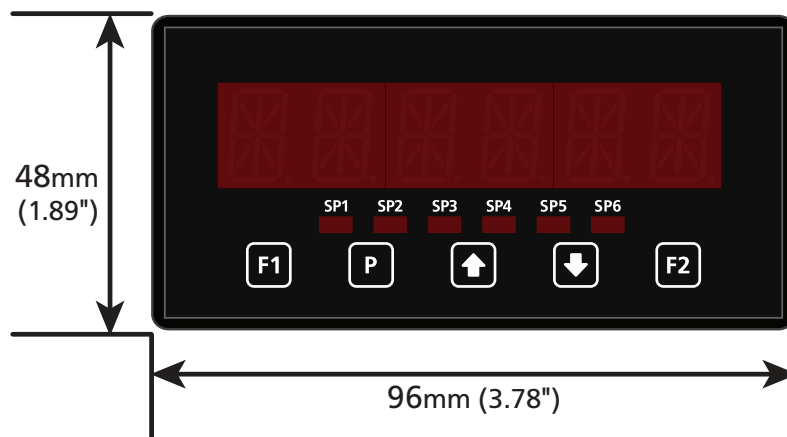

F2 This button is used to access the **Totalizer Reset & Setpoint Setup** menu (Section 6) and the **Setpoint Direct Access** menu (Section 7).





2.2 - Display brightness



To adjust the display brightness, press the **P** and **↑** buttons together from the main display. **BRI** appears and toggles with the current setting. Use the **↑** and **↓** buttons to adjust the LED backlight, and then press **P** to finish.

2.3 - Up and down button shortcuts

Pressing the  and  buttons from the main operational display allows instant access to a number of values held in the controller's memory. These variables will appear in the order shown in the table below, and will cycle continuously at each press of the  or  button. Press  at any time to return to normal operating mode.

PEAK and **VALLEY** may be reset to zero by pressing the  and  buttons **at the same time** while the variable is being displayed.

Up and down button shortcuts

	PEAK	Maximum measured flow rate since the instrument was turned on/reset
	TOTAL1	Current value of Total 1. <i>Total 1 will not appear in this list if it is set as your display source (5.5). This value can be reset in 6.2B, or by the input pins (3.6).</i>
	VALLEY	Minimum measured flow rate since the instrument was turned on/reset
	TOTAL2	Current value of Total 2. <i>Total 2 will not appear in this list if it is set as your display source (5.5). This value can be reset in 6.2C, or by the input pins (3.6).</i>

3

WIRING

BEFORE YOU BEGIN WIRING, ensure that the unit is switched off and the power supply is disconnected.

3.1 - Pinouts

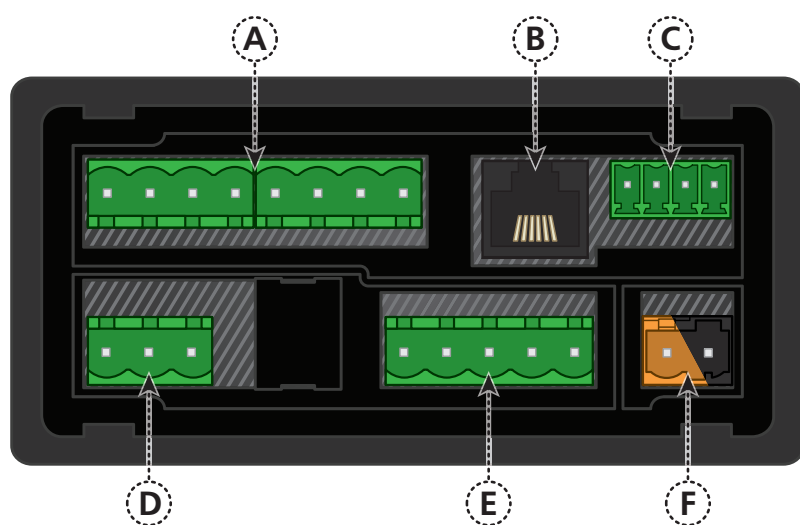

Key

3.1A Relay Output (See 3.3)

3.1B Serial Port (See 3.5)

3.1C Analog Output (See 3.4)

3.1D Analog Input (See 3.2)

3.1E Function Pins (See 3.6)

3.1F Power Supply HV/LV
(See 3.7)

3.2 - Wire the analog input module

See 3.1D

Wire your analog input module as required, referring to the diagrams below.

2-Wire Current Input External Excitation Used

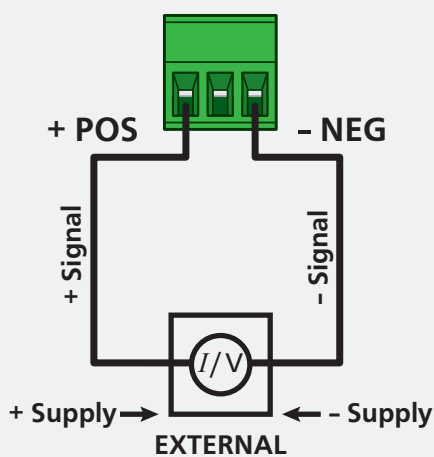

2-Wire Current Input Loop Powered Sensor

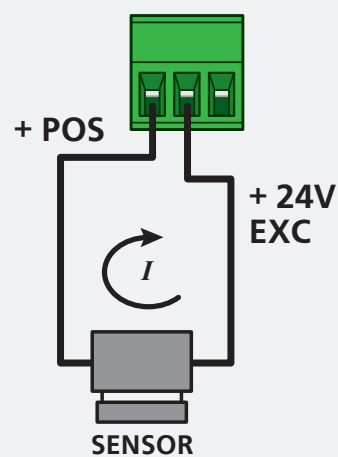

3-Wire Current Input Controller Supplied EXC

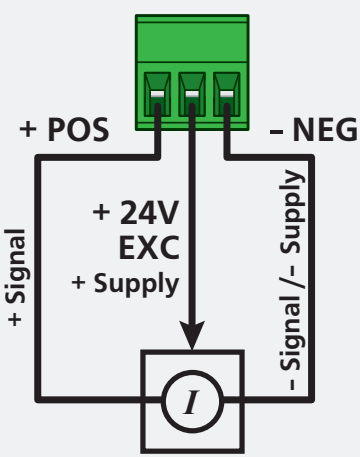

3.3 - Wire the relay outputs (if installed)

See 3.1A

If your controller has relay outputs fitted, wire them as shown below. Relays can be programmed to operate within the total span range of the controller.

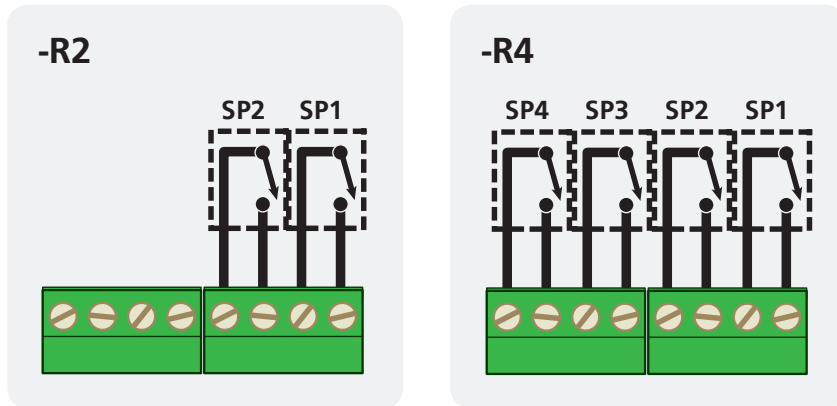

3.4 - Wire the analog output (if installed)

See 3.1C

If your controller has analog output fitted, wire it as shown for either voltage (0–10V) or current (4–20mA).

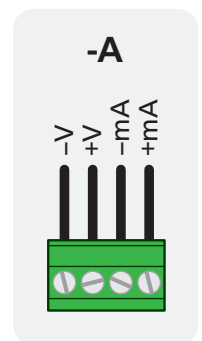

3.5 - Wire the serial port (if installed)

See 3.1B

If your controller has serial port fitted, wire it as shown in the applicable diagram.

- › S2R: RS232, RJ11 terminal
- › S4S: RS485, screw terminal

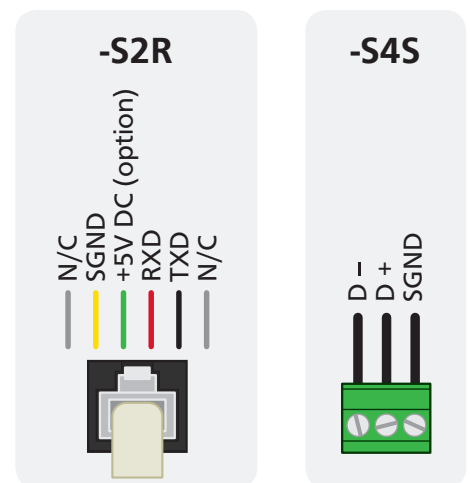

3.6 - Wire the function pins

See 3.1E

Connect external switches as shown to enable a function to be executed when its switch is activated.

- › **Total 1** Resets Total 1 to zero (also see 6.2B)
- › **Total 2** Resets Total 2 to zero (also see 6.2C)
- › **Test** Resets the meter
- › **Pk/Val** Clears the Peak & Valley readings (also see 2.3)

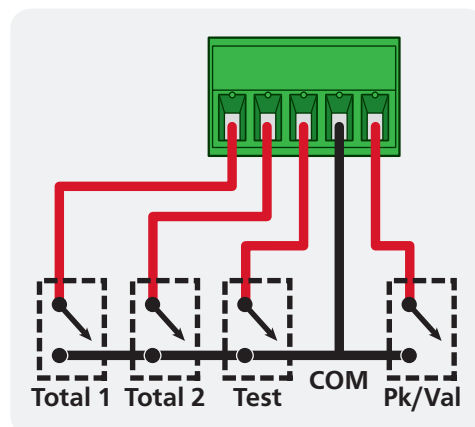

3.7 - Wire the power supply

See 3.1F

DO NOT attempt to wire your controller while the power is on. NEVER connect your low voltage controller to mains power.

Wire your controller for low or high voltage power supply, as show in the diagrams below. Check the label on the unit against the colour of the connector:

- › **Orange =**
High voltage (85–265V AC,
95–370V DC)
- › **Black =**
Low voltage (15–48V AC,
10–72V DC)

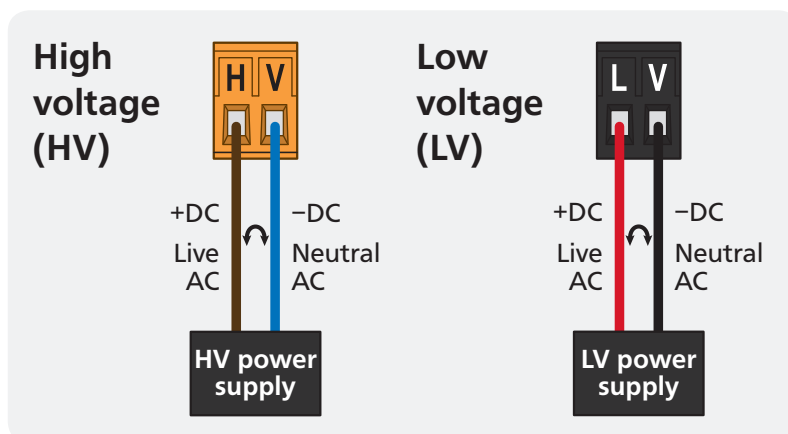

Once you have completed the wiring process it is safe to switch on your power supply. Ensure that your display is functioning before you proceed.

4

DIMENSIONS & INSTALLATION

4.1 - Case dimensions

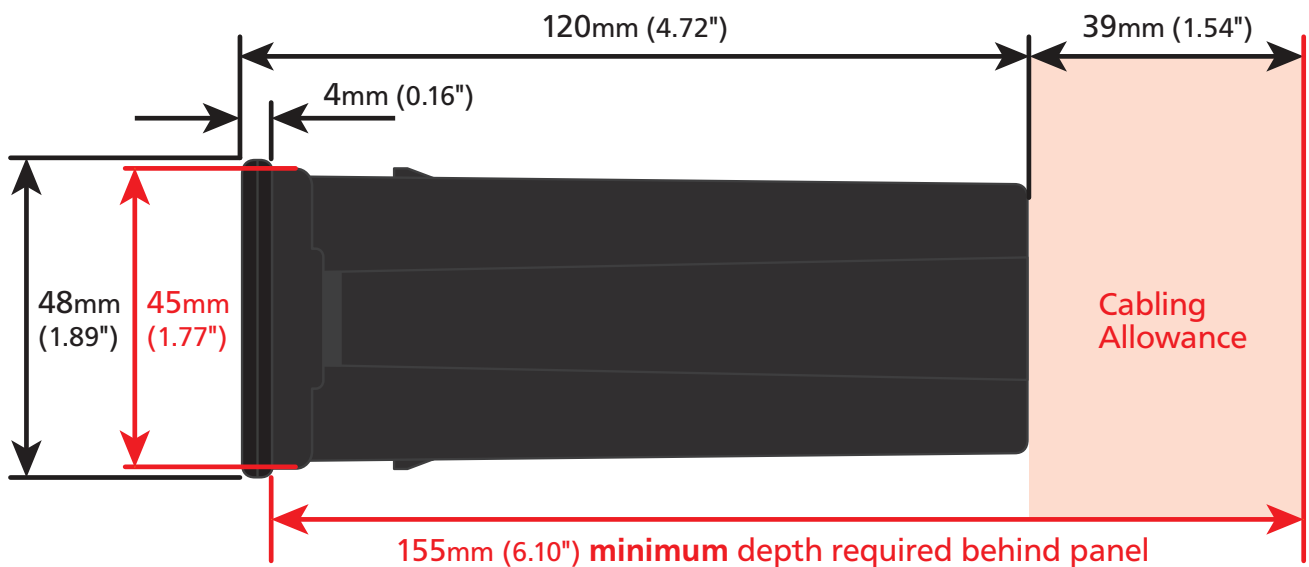
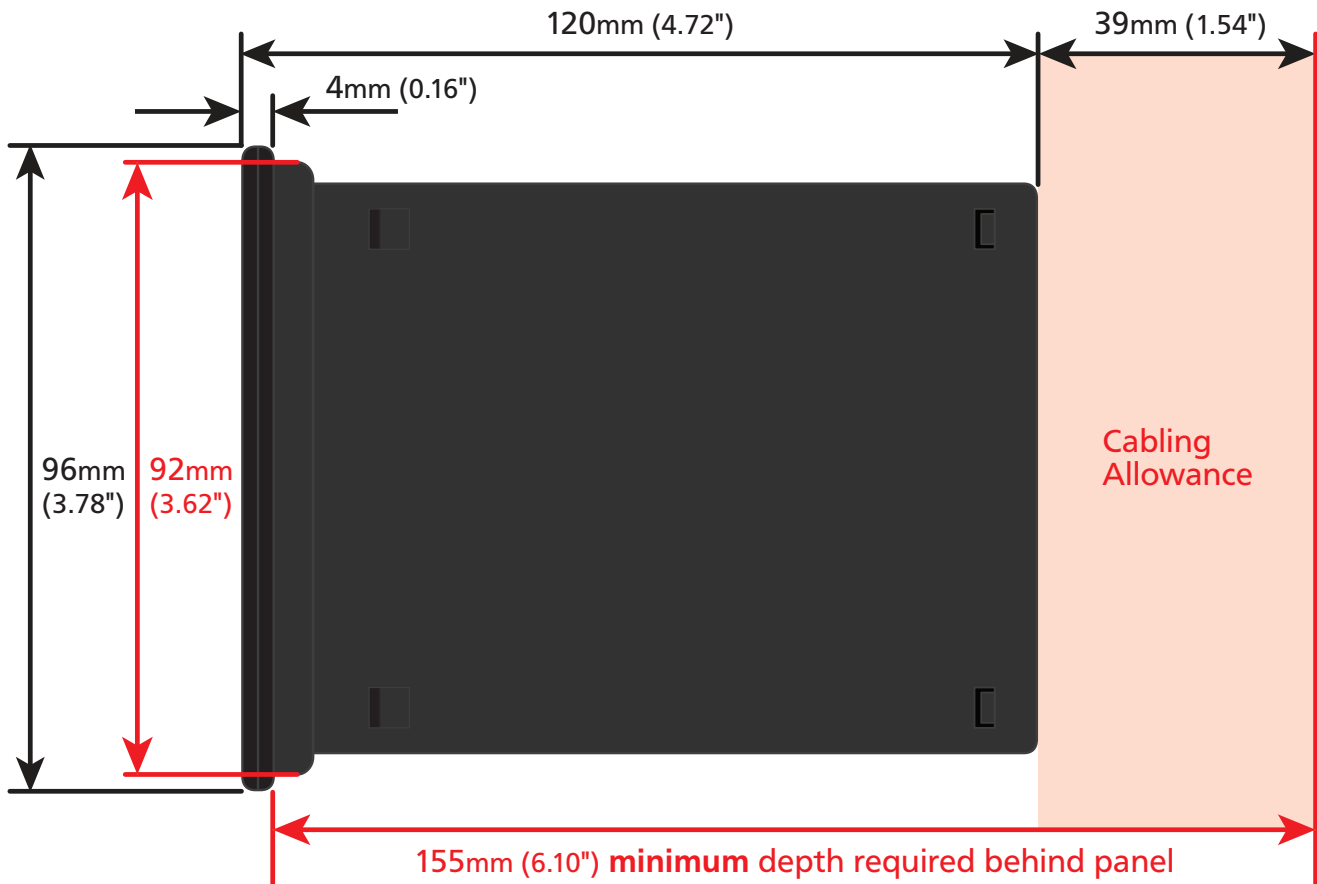

4.2 - Installation instructions

- A** Prepare the **Panel Cutout** to $92 \times 45\text{mm} \pm 0.5$ ($3.62 \times 1.77" \pm 0.02$), as shown below. **Allow at least 155mm (6.10") depth behind the panel to accommodate the meter body and protruding cabling.**
- B** Remove the **Mounting Clips** from the meter back.
- C** Slide the **Panel Gasket** over the rear of the unit to the back of the **Meter Faceplate**.
- D** From the front of the panel, insert the meter into the **Panel Cutout**. Holding the unit in place, engage the **Mounting Clips** so that the tabs snap into place over the notches on the case.

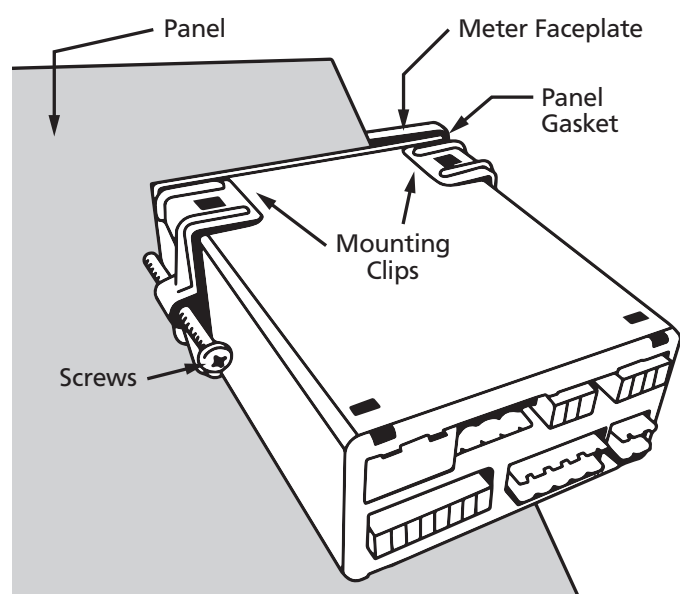

- E** To achieve a proper seal, tighten the **Screws** evenly until the unit sits firmly against the panel. Do not over-tighten the screws.

Panel Cutout

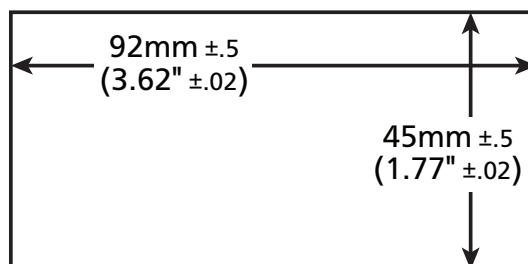

5

INPUT SETUP & CALIBRATION

5.1 - Enter F1 PIN number

A Enter the calibration mode by pressing the **F1** button.

__ ENTER F1 PIN NUMBER scrolls across the display and toggles with **0**. Use the **↑** and **↓** buttons to enter your security code (factory default 1). Then press **P**. If the correct PIN is entered, setup is started at 5.2.

If an incorrect PIN number is entered, **__ INCORRECT PIN** scrolls across the display and it returns to normal operating mode.

You will have the opportunity to change your PIN number at the end of this section (5.10). If you have forgotten your PIN number, see Section 8.

5.2 - Flow rate input setup

A **__ FLOW RATE INPUT SETUP** scrolls across the display and toggles with **SKIP**. Press **P** to skip to 5.3, or the **↑** button and then **P** to **ENTER** input setup.

B **__ MAINS FREQUENCY** scrolls across the display and toggles with the current selection. Use the **↑** and **↓** buttons to select **50HZ** or **60HZ**, and press **P**.

C **__ TIME UNITS FOR FLOW RATE** scrolls across the display and toggles with the current time units. Use the **↑** and **↓** buttons to select: **/SEC**, **/MIN**, or **/HR**, and then press **P**.

D **__ RESOLUTION FOR FLOW RATE** scrolls across the display and toggles with the current flow resolution. Use the **↑** and **↓** buttons to select: **1**, **0.1**, **0.01**, or **0.001**, and then press **P**.

5.3 - Total 1 setup

- A** **__ TOTAL 1 SETUP** scrolls across the display and toggles with **SKIP**. Press **P** to skip to 5.4, or the **↑** button and then **P** to **ENTER** Total 1 setup.
- B** **__ RESOLUTION OF TOTAL 1** scrolls across the display and toggles with the currently selected Totalizer 1 resolution. Use the **↑** and **↓** buttons to choose between: **X0.1**, **X1**, **X10**, **X100** or **X1000**. Then press **P**.
- C** **__ LOW FLOW LIMIT FOR TOTAL 1** scrolls across and toggles with the current low flow cut-off value for Totalizer 1. Use the **↑** and **↓** buttons to adjust this value as needed, and then press **P**.
- D** **__ ROLL OVER—TOTAL 1** scrolls across and toggles with the current roll over setting. Use the **↑** and **↓** buttons to select **ON** or **OFF**, and then press **P**.

*This parameter controls the behaviour of the totalizer when it exceeds its maximum display value (999999 display counts). **ON**= The display will roll over to 0 once it passes its limit. **OFF**= The display will show **OVER** once it passes its limit, and will not roll over to 0.*

5.4 - Total 2 setup

- A** **__ TOTAL 2 SETUP** scrolls across the display and toggles with **SKIP**. Press **P** to skip to 5.5, or the **↑** button and then **P** to **ENTER** Total 2 setup.
- B** **__ RESOLUTION OF TOTAL 2** scrolls across the display and toggles with the currently selected Totalizer 2 resolution. Use the **↑** and **↓** buttons to choose between: **X0.1**, **X1**, **X10**, **X100** or **X1000**. Then press **P**.
- C** **__ LOW FLOW LIMIT FOR TOTAL 2** scrolls across and toggles with the current low flow cut-off value for Totalizer 2. Use the **↑** and **↓** buttons to adjust this value as needed, and then press **P**.
- D** **__ ROLL OVER—TOTAL 2** scrolls across and toggles with the current roll over setting. Use the **↑** and **↓** buttons to select **ON** or **OFF**, and then press **P**.

*This parameter controls the behaviour of the totalizer when it exceeds its maximum display value (999999 display counts). **ON**= The display will roll over to 0 once it passes its limit. **OFF**= The display will show **OVER** once it passes its limit, and will not roll over to 0.*

5.5 - Display setup

- A** **__ DISPLAY SETUP** scrolls across and toggles with **SKIP**. Press **P** to skip to 5.6, or the **↑** button and then **P** to **ENTER** display setup.
- B** **__ DISPLAY SOURCE** scrolls across and toggles with the currently selected display source. Use the **↑** and **↓** buttons to select **FLOW**, **TOTAL1** or **TOTAL2**, and then press **P**.

*The values for **TOTAL1** and **TOTAL2** can also be viewed using the 'Up and Down Button Shortcuts' from the operational display (see 2.3).*

5.6 - Calibration

- A** **__ CALIBRATE FLOW INPUT** scrolls across the display and toggles with **SKIP**. Press **P** now to skip to 5.7, or use the **↑** and **↓** buttons to select a channel to calibrate: either **FLOW** or **MA I/P** (mA input), and press **P** to continue.
- ➔ If you selected **FLOW**, complete steps 5.6B–E now.
 - ➔ If you selected **MA I/P**, complete steps 5.6F–H now.
 - ➔ If you selected **SKIP**, skip to 5.7 now.

Flow calibration

- B** **__ INPUT RANGE** scrolls across the display and toggles with the currently selected input range. Use the **↑** and **↓** buttons to select either **0-20MA** or **4-20MA**, and then press **P**.
- C** **__ ENTER DISPLAY VALUE FOR [0/4] MA** scrolls across the display, and the currently selected low display value appears. Use the **↑** and **↓** buttons to set the display value for the low level input signal, and then press **P**.
- The text string for [0/4] MA is determined by your input range (selected in 5.6B).*
- D** **__ ENTER DISPLAY VALUE FOR 20 MA** scrolls across the display, and the currently selected high display value appears. Use the **↑** and **↓** buttons to set the display value for the high level input signal, and then press **P**.

- E** **__ CALIBRATE FLOW INPUT** scrolls across the display and toggles with **SKIP**. You are now back at 5.6A. Press **P** to skip to 5.7, or use the **↑** and **↓** buttons to select a new channel to calibrate, and then press **P**.

mA input calibration

- F** **__ APPLY 0 MA INPUT SIGNAL** scrolls across the display, and toggles with the zero value. Apply a 0mA input signal to the meter, and wait a moment for the signal to stabilise. Then press **P** to accept.

The 'zero value' quoted in this step is a fixed value which is used for internal calculations. It will not change as you apply your input signal, and cannot be user adjusted.

- G** **__ APPLY 20 MA INPUT SIGNAL** scrolls across the display, and toggles with the span value. Apply a 20mA input signal to the meter, and wait a moment for the signal to stabilise. Then press **P** to accept.

The 'span value' quoted in this step is a fixed value which is used for internal calculations. It will not change as you apply your input signal, and cannot be user adjusted.

- H** If 'mA Input' calibration was successful, you will be directed back to 5.6A. (To enter step 5.7, you must select **SKIP** at 5.6A.)

If calibration fails, **__ CALIBRATION FAILED** will scroll across the display and you will be directed back to 5.6A to try again. The most likely cause of this error is that the controller has not detected any change in input signal during the calibration process. Check your signal and connections, and calibrate again.

5.7 - Averaging

Your controller has input signal averaging, optimising stable measurement.

If the change in input exceeds the averaging window value it will not average, ensuring fast response when there are large differences between readings.

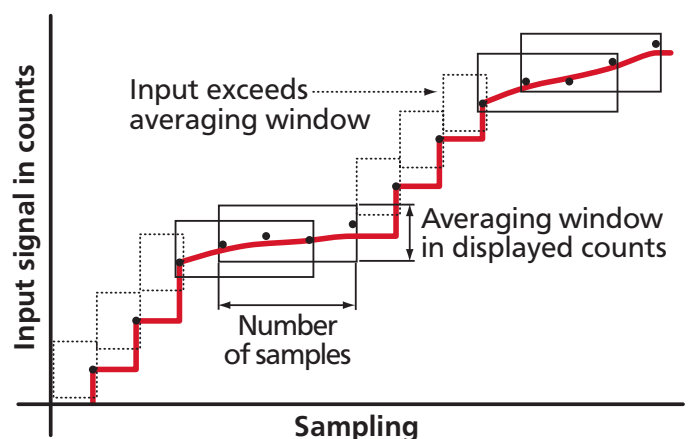

A **__ AVERAGING SETUP** scrolls across the display and toggles with **SKIP**. Press **P** to skip to 5.8, or the **↑** button and then **P** to **ENTER** averaging setup.

B **__ AVE SAMPLES** scrolls across the display and toggles with the currently selected averaging. Using the **↑** and **↓** buttons, alter the number of input samples that the controller will average, and then press **P**.

Increasing the number of samples will stabilise measurement, but it will also slow down response rates.

C **__ AVE WINDOW** scrolls across the display and toggles with the currently selected averaging window value. Using the **↑** and **↓** buttons, alter the signal averaging window. Then press **P**.

*If your input signal contains large noise spikes, you can increase the size of the averaging window to ensure that these are still averaged. However, increasing the window size too far will reduce the ability of the controller to respond quickly to real changes in input signal. Setting **AVE WINDOW** to 0 will give continuous averaging as per the selected averaging samples.*

5.8 - Analog output setup

A **__ ANALOG OUTPUT SETUP** scrolls across the display and toggles with **SKIP**. If your controller does not have analog output installed, (or you do not wish to configure your analog output now), press **P** to skip to 5.9.









Otherwise, press the **↑** button and then **P** to **ENTER** analog output setup.

B **__ DATA SOURCE FOR ANALOG O/P** scrolls across the display and toggles with the current analog output data source. Use the **↑** and **↓** buttons to select an option from: **FLOW**, **TOTAL1** or **TOTAL2**, and then press **P**.













C **__ LOW SCALE VALUE FOR ANALOG O/P** scrolls across the display and toggles with the currently selected low scale display value. Use the **↑** and **↓** buttons to enter your cal low position, and then press **P**.







D **__ HIGH SCALE VALUE FOR ANALOG O/P** scrolls across the display and toggles with the currently selected high scale display value. Use the **↑** and **↓** buttons to enter your cal high position, and then press **P**.

Analog output calibration is precisely set before shipping this instrument, and should not be adjusted unless advised by the manufacturer.

- E** **__ CALIBRATE ANALOG O/P?** scrolls across and toggles with **SKIP**. Use the  and  buttons to select **SKIP** or **ENTER**, and then press .
- ➔ If you selected **SKIP**, skip to 5.9 now.
 - ➔ If you selected **ENTER**, connect a mA or volt meter across the analog output connector (see 3.4), and then continue to 5.8F.
- F** **__ CAL LOW ANALOG O/P** scrolls across and toggles with a calibration number, displayed in internal units (mA/V). Using the  and  buttons, calibrate your low analog output as required, and press .
- G** **__ CAL HIGH ANALOG OUTPUT** scrolls across and toggles with a calibration number, displayed in internal units (mA/V). Using the  and  buttons, calibrate your high analog output as required, and press .

5.9 - Serial setup







- A** **__ SERIAL SETUP** scrolls across the display and toggles with **SKIP**. If your controller does not have a serial port installed, (or you do not wish to configure your serial options now), please press  to skip to 5.10. Otherwise, press the  button and then  to **ENTER** serial setup.
- B** **__ SERIAL MODE** scrolls across the display and toggles with the current serial mode. Use the  and  buttons to choose between: **ASCII** (custom), **MODBUS** (RTU), or **RNGR A** (Ranger A). Then press .
- ➔ If you selected **RNGR A**, continue to 5.9C now.
 - ➔ If you selected **ASCII** or **MODBUS**, skip to 5.9D now.
- See Appendix A for more information about the available serial modes.*
- C** **__ SERIAL DATA SOURCE** scrolls across the display and toggles with the currently selected serial data source. Use the  and  buttons to select an option from: **FLOW**, **TOTAL1**, or **TOTAL2**, and then press .
- D** **__ BAUD RATE** scrolls across the display and toggles with the current selection. Use the  and  buttons to select one of: **300**, **600**, **1200**, **2400**, **4800**, **9600**, **19200** or **38400**. Then press .

- E **__ PARITY** scrolls across the display and toggles with the currently selected parity. Using the  and  buttons, select: **NONE**, **ODD** or **EVEN**, and then press .
- F **__ SERIAL ADDRESS** scrolls across the display and toggles with the currently selected serial address. Use the  and  buttons to alter the serial address, and then press .

*The serial address parameter is used to identify a particular device when it is used with other devices in a system. (It applies particularly to **MODBUS** mode when used on an RS485 serial network.) The serial address of the controller must be set to match the serial address defined in the master device.*

Refer to Appendix A for more information on serial modes and registers.





5.10 - Edit F1 PIN number

- A **__ EDIT F1 PIN NUMBER?** scrolls across the display and toggles with **SKIP**. Press  to skip and return to the operational display, or the  button and then  to **ENTER** and change your PIN number.
- B **__ ENTER NEW F1 PIN** scrolls across the display and toggles with the current PIN (default 1). Using the  and  buttons, enter your new F1 PIN number. Then press  to exit to the operational display.

6

TOTALIZER RESET & SETPOINT SETUP

6.1 - Enter F2 PIN number

- A Enter setpoint setup mode by pressing and holding the  button for 3 seconds.
- __ ENTER F2 PIN NUMBER** scrolls across the display and toggles with **0**. Use the  and  buttons to enter your security code (factory default 1). Then press . If the correct PIN is entered, setup is started at 6.2.

If an incorrect PIN number is entered, **__ INCORRECT PIN** scrolls across the display and it returns to normal operating mode.

You will have the opportunity to change your PIN number at the end of this section (6.4). If you have forgotten your PIN number, see Section 8.



6.2 - Reset totalizers

- A** **__ RESET TOTALIZERS?** scrolls across the display and toggles with **SKIP**. Press **[P]** to skip to 6.3, or the **[↑]** button and then **[P]** to **ENTER** totalizer reset mode.
- B** **__ RESET TOTAL 1** scrolls across the display and toggles with the current selection. Use the **[↑]** and **[↓]** buttons to select **NO** or **YES**, and then press **[P]**.
Selecting YES will reset Total 1 to zero.
- C** **__ RESET TOTAL 2** scrolls across the display and toggles with the current selection. Use the **[↑]** and **[↓]** buttons to select **NO** or **YES**, and then press **[P]**.
Selecting YES will reset Total 2 to zero.
-

6.3 - Setpoint setup



The software in your controller will allow you to configure up to 4 setpoints, however full functionality is only supported when relay output hardware installed. (Setpoints with no corresponding relay output hardware may be used as simple LED indicators, if desired. In this case, features requiring relay output functionality will continue to appear in the setup menu, but will be ignored by the controller.)

- A** **__ EDIT SETPOINT** scrolls across the display and toggles with **SKIP**. Press **[P]** now to skip to 6.4, or use the **[↑]** and **[↓]** buttons to select a setpoint to edit, and then press **[P]**.
- B** **__ SP SOURCE** scrolls across the display and toggles with the activation source for the selected setpoint. Use the **[↑]** and **[↓]** buttons to select: **FLOW**, **TOTAL1** or **TOTAL2**, and then press **[P]**.
-

C **__ SP VALUE** scrolls across the display and toggles with the current value for the selected setpoint. Using the  and  buttons, adjust the display value at which the selected setpoint will activate, and then press .



D The step that you proceed to now will depend on your *SP Source* (see in 6.3B):

- ➔ If you are selected **TOTAL2**, continue to 6.3E now.
- ➔ If you are selected **FLOW** or **TOTAL1**, skip to 6.3G now.



E **__ VOLUMETRIC PULSE** scrolls across the display and toggles with the current selection. Use the  and  buttons to select **OFF** or **ON**, and then press .

*When the selected setpoint is activated in volumetric pulse mode, **TOTAL2** will reset to 0 and then resume totalizing. This is useful for feeding volume information to other equipment.*



- ➔ If you are selected **ON**, continue to 6.3F now.
- ➔ If you are selected **OFF**, skip to 6.3G now.

F **__ PULSE TIME** scrolls across the display and toggles with the current selection. Use the  and  buttons to adjust the pulse time (from 0.1–10.0 seconds), and then press .

Pulse time is adjusted in tenths of a second to suit the requirements of externally connected devices. A combination of high input rates and low setpoint values may result in missed output pulses.

G **__ SP ACTIVATION** scrolls across the display and toggles with the current activation for the selected setpoint. Using the  and  buttons, select the relay activation to operate **ABOVE** or **BELOW** the setpoint value, and then press .

***ABOVE:** Relay turns on above the setpoint value and off below it. **BELOW:** Relay turns on below the setpoint value and off above it.*

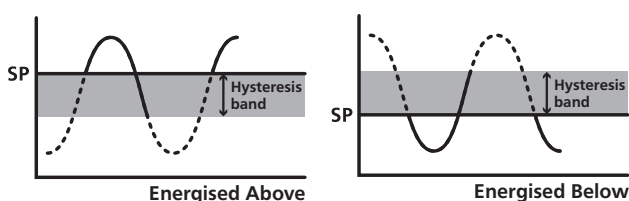

H **__ SP TYPE** scrolls across the display and toggles with the current type for the selected setpoint. Using the  and  buttons, select either **ALARM** or **CNTRL** (control), and then press .

***ALARM - SP VALUE** controls setpoint activation point. **HYSTERESIS VALUE** controls setpoint deactivation point.*



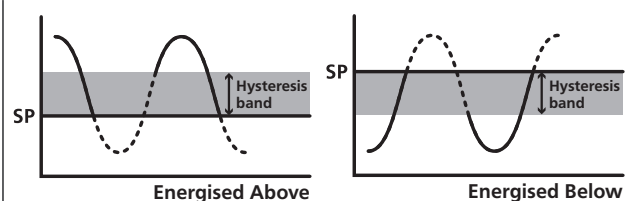





***CNTRL - SP VALUE** controls setpoint deactivation point. **HYSTERESIS VALUE** controls setpoint reactivation point.*





- I **__ HYSTERESIS VALUE** scrolls across the display and toggles with the hysteresis value for the selected setpoint. Use the  and  buttons to adjust this value if required, and then press .

*The **HYSTERESIS VALUE** defines the separation band between setpoint activation and deactivation, and will operate as per the **SP TYPE** setting selected in 6.3H.*



- J **__ MAKE DELAY** scrolls across the display and toggles with the current make delay time for the selected setpoint. This is the time delay between setpoint activation, and when the relay turns on. Adjust this value in 0.1 second increments using the  and  buttons, and then press .



- K **__ USER ACCESS?** scrolls across the display and toggles with the direct access permission setting for the selected setpoint. Use the  and  to select either **OFF** or **ON**, and then press .

When enabled, this option allows the selected setpoint's value to be edited directly after pressing the  button, without needing to enter a PIN number or go through all of the other options. Each setpoint can individually have this option enabled or disabled. See Section 7.

- L **__ EDIT SETPOINT** scrolls across the display and toggles with **SKIP**. You are now back at 6.3A. To edit another setpoint, follow the instructions from 6.3A–L again. If you do not wish to edit another setpoint, press  now to skip to 6.4.

6.4 - Edit F2 PIN number

- A **__ EDIT F2 PIN NUMBER?** scrolls across the display and toggles with **SKIP**. Press  to skip and return to the operational display, or the  button and then  to **ENTER** and change your PIN number.

- B **__ ENTER NEW F2 PIN** scrolls across the display and toggles with the current PIN (default 1). Using the  and  buttons, enter your new F2 PIN number. Then press  to exit to the operational display.

7

SETPOINT DIRECT ACCESS

If none of the setpoints have their direct access option enabled then this feature will be disabled and the **F2** button will not respond to a short button press. (See 6.3K.)

- A Begin by pressing the **F2** button for less than 3 seconds.
- B The name of the first access-enabled setpoint will appear on the display and toggle with the current value for that setpoint. Using the **↑** and **↓** buttons, adjust the selected value. Then press **P** to accept and continue.
- C The name of the next access-enabled setpoint will appear on the display, along with its setpoint value. Repeat step 7B. The direct access menu will proceed through all access-enabled setpoints in this fashion. Pressing **P** for the last enabled setpoint will exit and return to the operational display.

8

RESET PIN NUMBERS / VIEW FIRMWARE VERSION

If you have forgotten your PIN number(s), follow the procedure below to reset both the F1 and F2 PINs to their factory default of 1.

This procedure will also allow you to view the current software installed on your controller, which may be required for support purposes.

- A Press **↑**, **↓** and **P** at the same time. (This key combination can be difficult to execute and you may need several tries to get it right.)
- B A message will appear on the display, with details of the unit's current software configuration (Product Name, Firmware Version, and Macro Version). At the end, you will see – **ALL PIN NUMBERS RESET**.
- C Both the F1 PIN number and the F2 PIN number have now been reset to '1'. You can change this, if required, by following the instructions in 5.10 (for the F1 menu) and 6.4 (for the F2 menu), using '1' to enter each menu initially.

A**APPENDIX A - SERIAL MODES**

A.1 - Custom ASCII mode

Custom ASCII is a simple, custom protocol that allows connection to various PC configuration tools. ('Custom ASCII' differs from the 'Modbus (ASCII)' protocol used by some devices.) Custom ASCII command strings must be constructed in this order:

**<Start> <Controller Address> <Read/Write Command> <Register Address>
<Separator Character> <Data Value> <Message Terminator>**

Start - Use 'S' for the start character of a command string (not case sensitive). This must be the first character in the string.

Controller Address - Use an ASCII number from '1' to '255' for the controller address. If the character following the start character is not an ASCII number, then address '0' is assumed. All controllers respond to address '0'.

Read/Write Command - Use ASCII 'R' for read, 'U' for unformatted read, or 'W' for write (not case sensitive). Any other character aborts the operation.

In Custom ASCII mode, data is normally read as formatted data (which includes decimals and any text characters that may be selected to show units). However it is also possible to read unformatted data by using a 'U' in the read command. There is no unformatted write command, as when writing to fixed point registers, any decimal point and text characters are ignored.

Register Address - The register address for the read/write operation will be an ASCII number from '1' to '65535'. This character must be specified for a write command, but may be omitted for a read command, (in which case the controller will respond with the data value currently on the display).

Separator Character - The separator character can be either a space or a comma, and is used to separate the register address from the data value.

Data Value - Must be an ASCII number. The absolute limits for this number are -1000000 to +1000000, but note that not all registers will accept this range.

Message Terminator - This is the last character, and must be either a '\$' (dollar) or an '*' (asterisk). Neither of these characters should be used elsewhere in the message string. If '\$' is used, a 50ms minimum delay is inserted before a reply is sent. If '*' is used, a 2ms minimum delay is inserted before a reply is sent.

Custom ASCII Read/Write Examples

Example	Description
S15R\$	Read display value from controller address 15, 50ms delay.
S3U40*	Read unformatted data in channel 4 from controller address 3, 2ms delay.
S2W2 -10000\$	Write -10000 to the display register of controller address 2, 50ms delay.
SWT CHAN_1\$	Write ASCII text string Chan_1 to channel 1 text register, 50ms delay.

Custom ASCII Registers - *Active for models with relay output installed*

16 Bit Unsigned		32 Bit Signed	
Address	Function	Address	Function
1	Alarm status (SP1=Bit 0, SP2=Bit 1, SP3=Bit 2, SP4=Bit 3)	2	Process display
65-68	Hysteresis (SP1=65, SP2=66, SP3=67, SP4=68)	3	Flow rate
71-74	Make delay (SP1=71, SP2=72, SP3=73, SP4=74)	6-9	Setpoint 1-4 (SP1=6, SP2=7, SP3=8, SP4=9)
		12	Peak
		13	Valley
		16	Total 1
		17	Total 2
		34	D/A scale low value
		36	D/A scale high value

Controller Response - After the controller has completed a read or write instruction, it responds by sending a carriage return/line feed (CR/LF) back to the host. If the instruction was a read command, the CR/LF follows the last character in the ASCII string. If it was a write command, CR/LF is the only response sent back. The host must wait for this before sending further commands to the controller. If the controller encounters an error, it will respond with a null (0x00) CR/LF.

A.2 - Modbus (RTU) mode

Modbus (RTU) is an industry standard RTU slave mode that allows connection to a wide range of devices. Modbus registers are all holding registers, and should be accessed via function codes 3 and 6.

Register addresses are displayed in the Modicon™ 5-digit addressing format. I.e. Register 65=40065 (subtract 1 for direct addressing).

Modbus (RTU) Registers - Active for models with relay output installed

16 Bit Unsigned		32 Bit Signed (2 x 16 Bit)		
Address	Function	LSW	MSW	Function
40001	Alarm status (SP1=Bit 0, SP2=Bit 1, SP3=Bit 2, SP4=Bit 3)	40513	40514	Process display
40065– 40068	Hysteresis (SP1=40065, SP2=40066, SP3=40067, SP4=40068)	40515	40516	Flow rate
40071– 40074	Make delay (SP1=40071, SP2=40072, SP3=40073, SP4=40074)	40525	40526	Peak
		40527	40528	Valley
		40529	40530	Total 1
		40531	40532	Total 2
		40535	40536	Setpoint 1–4 (SP1=40535, SP2=40537, SP3=40539, SP4=40541)
		–541	–542	
		40587	40588	D/A scale low value
		40591	40592	D/A scale high value

A.3 - Ranger A mode

Ranger A is a continuous output, used to drive remote displays and other instruments in the Rinstrum™ range. (Ranger is a trade name belonging to Rinstrum Pty Ltd.) Ranger A output strings are constructed as shown:

<Start> <Sign> <Output Value> <Status> <End>

Start - STX character (ASCII 02)

Sign - Output value sign (space for + and dash for -)

Output Value - Seven character ASCII string containing the current output value and decimal point. (If there is no decimal point, then the first character is a space. Leading zero blanking applies.)

Status - Single character output value status. 'U'=Under, 'O'=Over, 'E'=Error.

End - ETX character (ASCII 03)



Define Instruments

New Zealand (Head Office)

 10B Vega Place, Mairangi Bay,
Auckland 0632, New Zealand
PO Box 245 Westpark Village,
Auckland 0661, New Zealand

Ph: +64 (9) 835-1550 | **Aus:** 1800 810-820

Fax: +64 (9) 835-1250

 sales@defineinstruments.co.nz

www.defineinstruments.co.nz

United States (Dallas, TX)

Ph: 214.926.4950

 sales@defineinstruments.com

www.defineinstruments.com

South Africa (Johannesburg)

Ph: 087 945 2700

 sales@defineinstruments.co.za

www.defineinstruments.co.za