



TEX-FLO10

Flow Rate Dual Totalizer



This sophisticated panel mount controller is the ideal solution for a variety of flow rate applications.

It features a customizable display, dual totalizers with low flow cutoff, volumetric pulse on setpoints, and batching on Total 1.

It's also designed for ease of use, with intuitive, scrolling text prompts that guide you step-by-step through the setup process, and simple K-factor entry.

Order Codes

TEX-FLO10

- HV 85–265V AC / 95–370V DC
- LV 15–48V AC / 10–72V DC

Options

- R2 2 x relay outputs
- R4 4 x relay outputs
- A 1 x mA/V analog output
- S2R 1 x RS232 (RJ11 terminal)
- S4S 1 x RS485 (screw terminal)

Contents

1 - Specifications	2
2 - Front Panel & Display	3
3 - Wiring	5
4 - Dimensions & Installation	9
5 - Input Header Adjustment	11
6 - Input Setup & Calibration	13
7 - Totalizer Reset & Setpoint Setup	19
8 - Setpoint Direct Access	23
9 - Reset PIN Numbers / View Firmware Version	23
A - Appendix A - Serial Modes	24

1

SPECIFICATIONS

Input

Sensor type NPN (open collector), PNP, Mag (20mV to 30V), TTL, digital, closed contact or namur

Input 0–24V DC, 0–30V AC

Power supply HV= 85–265V AC / 95–370V DC, or LV= 15–48V AC / 10–72V DC

Sensor calibration Direct K factor entry

K factor ranges 3 ranges for K factors, from 0.1 to 99.9999, 999.999 or 9999.99

Flow rate /sec, /min or /hour

Flow resolution 1, 0.1, 0.01 or 0.001

Totalizer resolution x0.1, x1, x10, x100 or x1000

Totalizer reset Using the function pins, the **F2** button, or the volumetric pulse function

Volumetric pulse on Total 2, with adjustable pulse width from 0.1–10.0 seconds

Frequency 2Hz to 10KHz

Excitation 24V DC (50mA max) provided by controller

Accuracy 0.005%

Temperature drift Typically 2ppm/°C

Relay Output

OPTIONAL

Number of relay outputs None, 2 or 4

Relay output type 5A form A (3A 240V AC max or 3A 30V DC max)

Analog Output

OPTIONAL

Number of analog outputs None or 1

Analog output type Isolated 16 bit 4–20mA/0–10V

Comm Port

OPTIONAL

Number of comm ports None or 1

Comm port options

S2R= Isolated RS232, RJ terminal, or
S4S= Isolated RS485, screw terminal

Serial output Custom ASCII, Modbus RTU slave or Ranger A

Data rate 300–38400 baud

Parity Odd, even or none

Programming

Front panel buttons Up, Down, P (Prog/Enter), plus 2 Menu buttons (F)

Security Input and setpoint setups are independently accessible and PIN protected

Display

Display type 14 segment alphanumeric LED display, 5 buttons

Digits 1 x 6 digits, 13mm (0.5")

LED indicators 6 setpoint LED's

Construction

Casing Panel mount case

Ingress protection rating IP65 dust/splash proof (face only)

Dimensions (H x W x D)

48 x 96 x 120mm (1.89 x 3.78 x 4.72")

Panel cutout 45 x 92mm (1.77 x 3.62")

2

FRONT PANEL & DISPLAY

2.1 - Front panel

SPX The SP LED's are used to indicate active setpoints.

F1 This button is used to access the **Input Setup & Calibration** menu (Section 6).

P This button is used to save your settings and advance to the next step in the setup process. It can also be configured to reset the batch value to zero after a long press (> 2secs) from the main display (see 6.4E to enable).

↑ This button is typically used to scroll through options or increase values in the setup menu. Pressing this button from the main display will show the current values for **FLOW** and **TOTAL1**, (excluding either value if it is set as the display source in 6.6B). See 2.3.

↓ This button is typically used to scroll through options or decrease values in the setup menu. Pressing this button from the main display will show the current

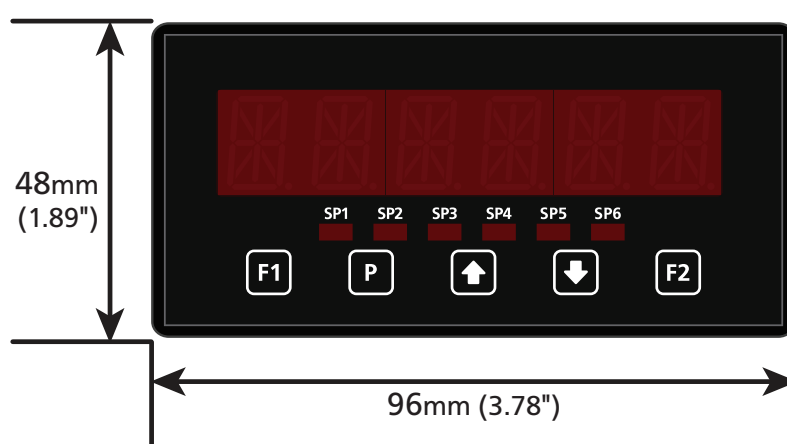

value for **TOTAL2**, (unless the display source is set to **TOTAL2** in 6.6B). See 2.3.

F2 This button is used to access the **Totalizer Reset & Setpoint Setup** menu (Section 7) and the **Setpoint Direct Access** menu (Section 8).

2.2 - Display brightness

To adjust the display brightness, press the **P** and **↑** buttons together from the main display. **BRI** appears and toggles with the current setting. Use the **↑** and **↓** buttons to adjust the backlight, and then press **P** to return to operating mode.

2.3 - Up and down button shortcuts

Pressing the **↑** and **↓** buttons from the main operational display allows instant access to a number of values held in the controller's memory. These variables will appear in the order shown in the table below, and will cycle continuously at each press of the **↑** or **↓** button. Press **P** at any time to return to normal operating mode.

Up and down button shortcuts

↑	FLOW	Current flow rate value
	TOTAL1	Current value of Totalizer 1
↓	TOTAL2	Current value of Totalizer 2

If any of these values are set as your display source in 6.6B, they will be excluded from this quick-display menu. **TOTAL1** and **TOTAL2** can be reset using an external switch connected to the function pins (see 3.1D).

Press **P** at any time to return to the main display.

3

WIRING

3.1 - Pinouts

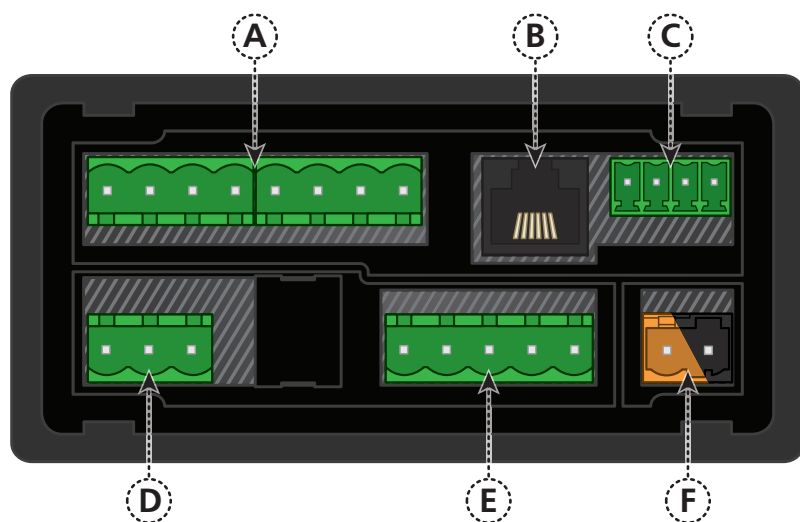

Key

3.1A Relay Output (See 3.3)

3.1B Serial Port (See 3.5)

3.1C Analog Output (See 3.4)

3.1D Analog Input (See 3.2)

3.1E Function Pins (See 3.6)

3.1F Power Supply (See 3.7)

3.2 - Wire the analog input module

See 3.1D

IMPORTANT: The input module for this unit has four headers which are factory configured to suit your application. The unit is configured for an NPN type sensor by default.

- ➔ If you are using an **NPN** type sensor, you don't need to change anything.
- ➔ If you are using **PNP, TTL, Namur, Tacho,** or a **Pushbutton switch**, please review your header configuration before continuing, referring to Section 5.

Then wire your input as required, referring to the diagrams on the following page.

NPN open collector output with proximity switch

- › Active sensor signal: 0V
- › Inactive sensor signal: +24V

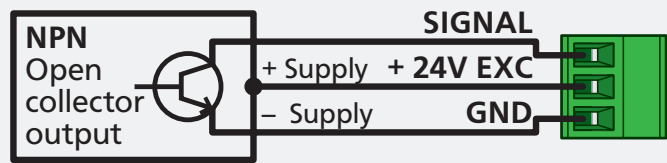

PNP open collector output with proximity switch

- › Active sensor signal: +24V
- › Inactive sensor signal: 0V

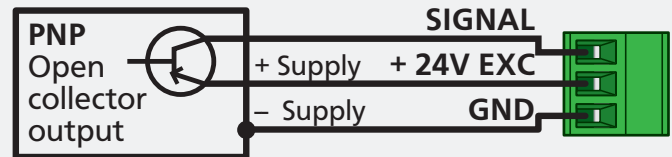

Pushbutton switch

- › Open signal: +24V
- › Closed signal: 0V

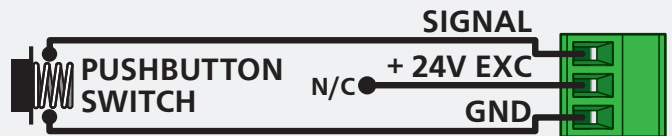

Tacho generator sensor

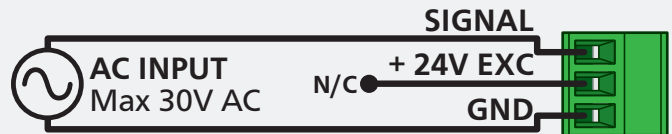

TTL input

- › In this example the TTL logic has a separate +5V power supply

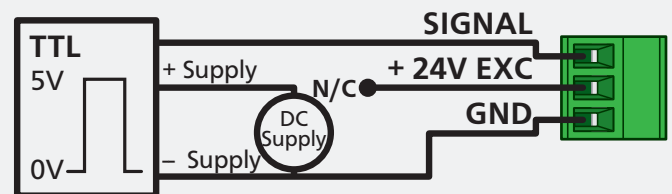

Namur sensor

- › Active sensor signal: 0.3–1.0mA
- › Inactive sensor signal: 1.7–3.0mA

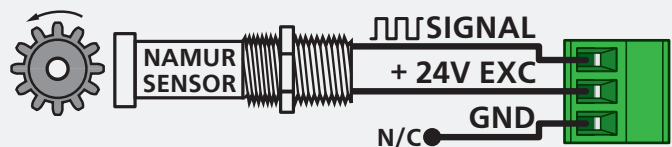

3.3 - Wire the relay outputs

See 3.1A

If your controller has relay outputs fitted, wire them as per the appropriate diagram below, depending on how many relay outputs you have installed. Relays can be programmed to operate within the total span range of the controller.

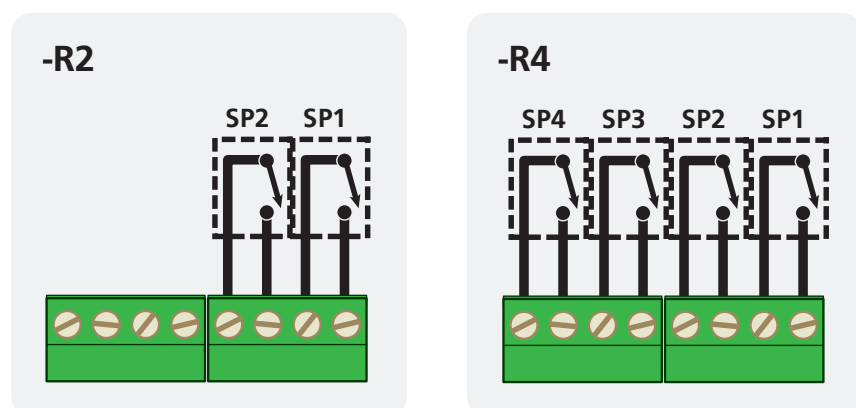

3.4 - Wire the analog output

See 3.1C

If your controller has analog output fitted, wire it as shown for either voltage (0–10V) or current (4–20mA).

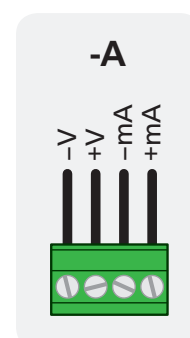

3.5 - Wire the serial port

See 3.1B

If your controller has a serial port fitted, wire it as shown in the applicable diagram.

- › **S2R** RS232, RJ11 terminal
- › **S4S** RS485, screw terminal

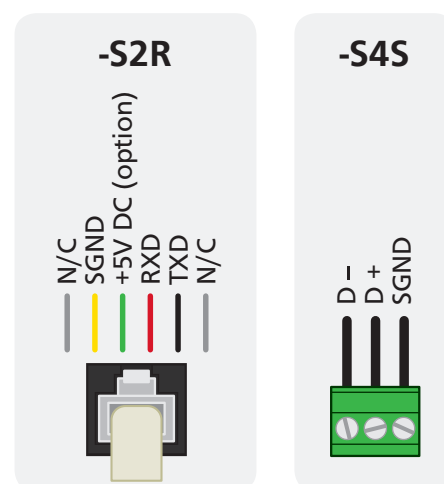

3.6 - Wire the function pins

See 3.1E

Connect external switches to enable a function to be executed when its switch is activated.

- › **Total 1:** Resets Total 1 to zero
- › **Total 2:** Resets Total 2 to zero
- › **Test:** Resets the unit
- › **Batch:** Resets Batch to zero

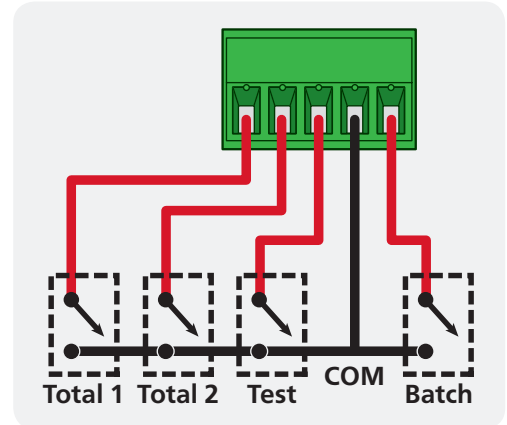

3.7 - Wire the power supply

See 3.1F

NEVER connect your low voltage controller to mains power.

Wire your controller for low or high voltage power supply, as show in the diagrams below. Check the label on the unit against the colour of the connector:

- › **Orange =**
High voltage (85–265V AC,
95–370V DC)
- › **Black =**
Low voltage (15–48V AC,
10–72V DC)

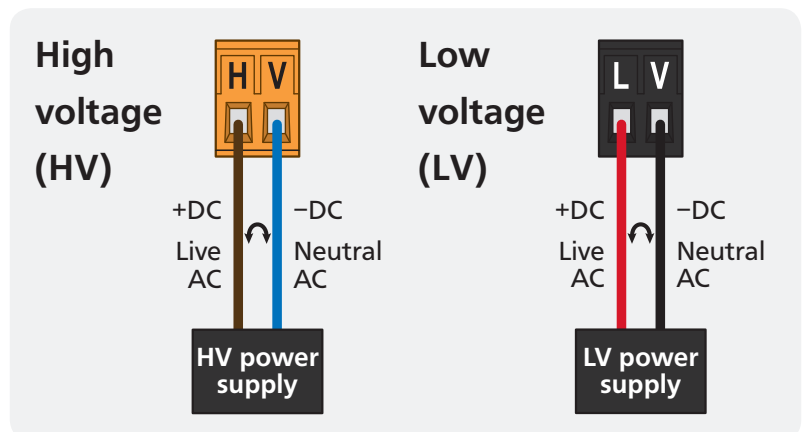

Once you have completed the wiring process it is safe to switch on your power supply. Ensure that your display is functioning before you proceed.

4

DIMENSIONS & INSTALLATION

4.1 - Case dimensions

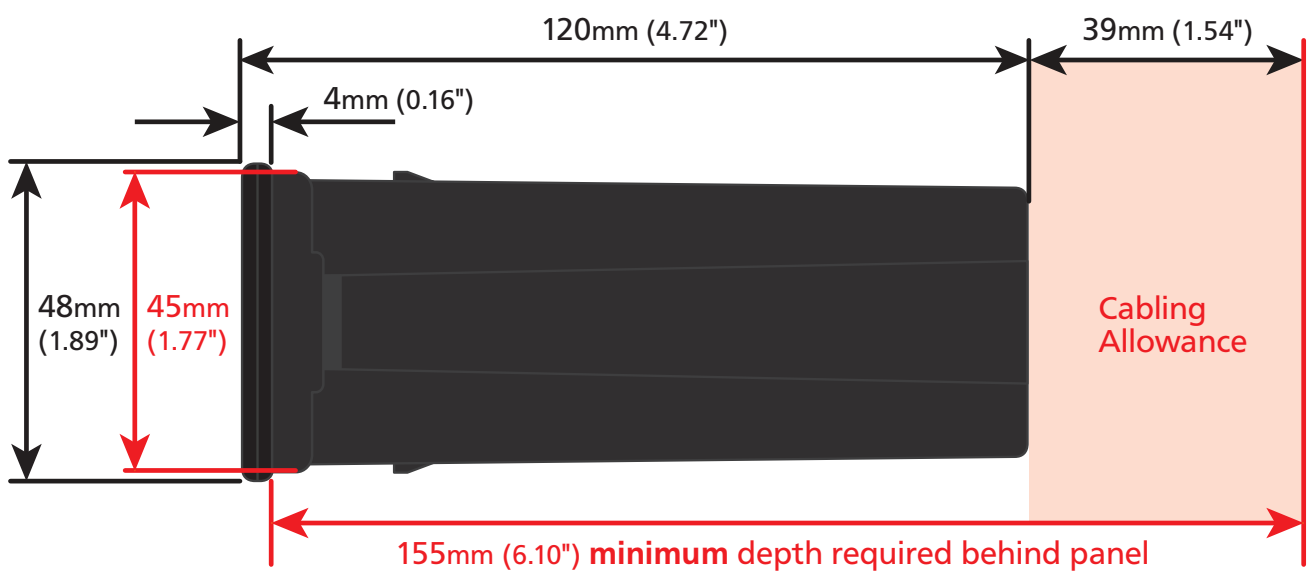
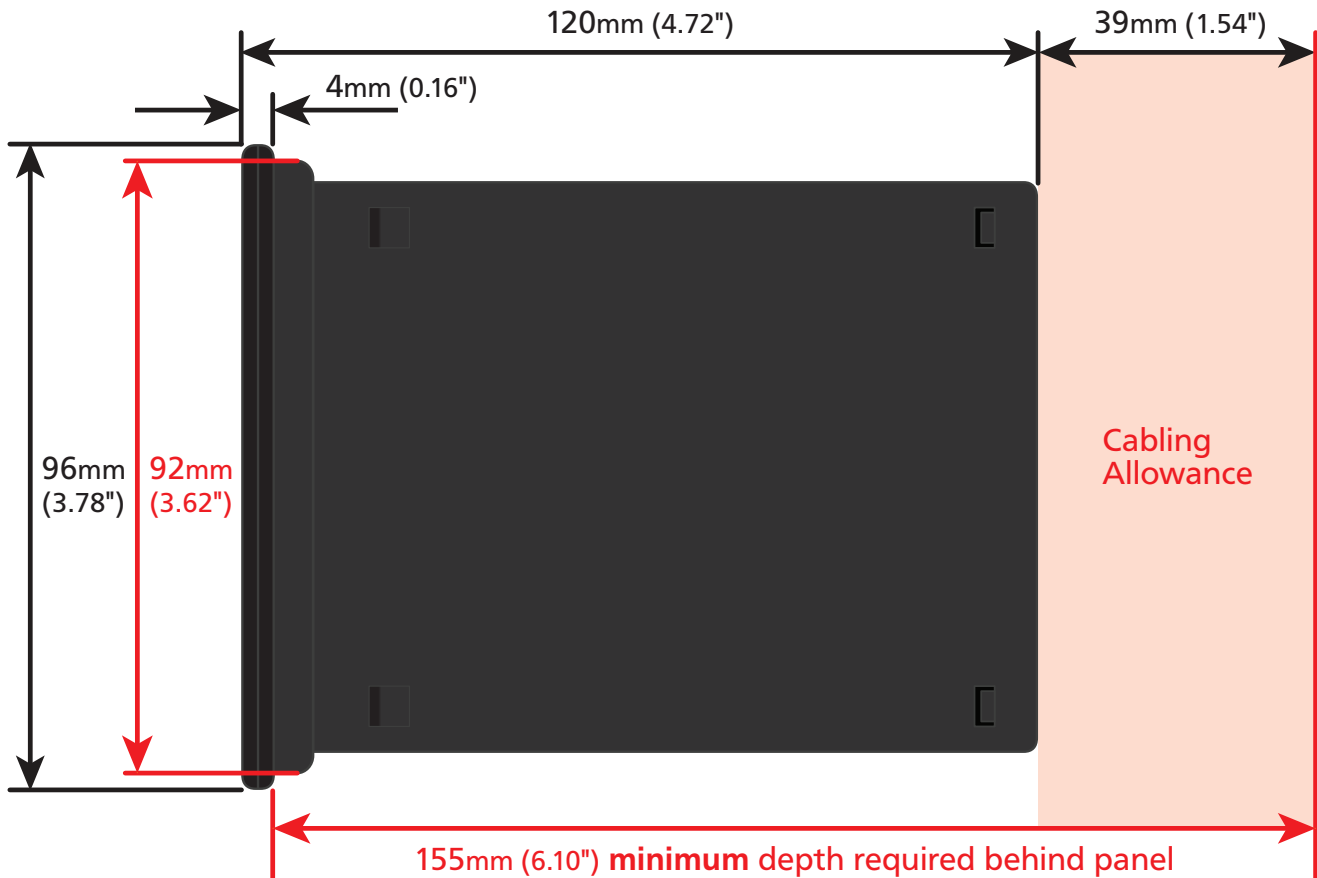

4.2 - Installation instructions

A Prepare the **Panel Cutout** to $92 \times 45\text{mm} \pm 0.5$ ($3.62 \times 1.77" \pm 0.02$), as shown below.

Allow at least 155mm (6.10") depth behind the panel to accommodate the meter body, protruding connectors and cabling.

B Remove the **Mounting Clips** from the meter back.

C Slide the **Panel Gasket** over the rear of the unit to the back of the **Meter Faceplate**.

D From the front of the panel, insert the meter into the **Panel Cutout**. Holding the unit in place, engage the **Mounting Clips** so that the tabs snap into place over the notches on the case.

E To achieve a proper seal, tighten the **Screws** evenly until the unit sits firmly against the panel. Do not over-tighten the screws.

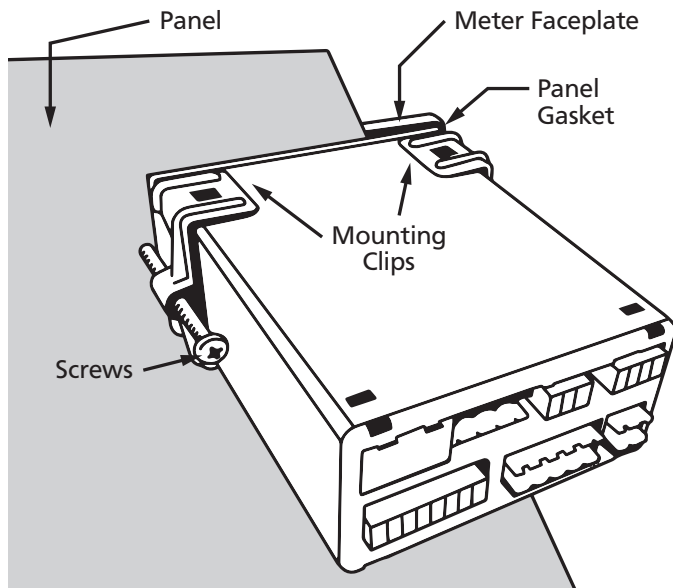

Panel Cutout

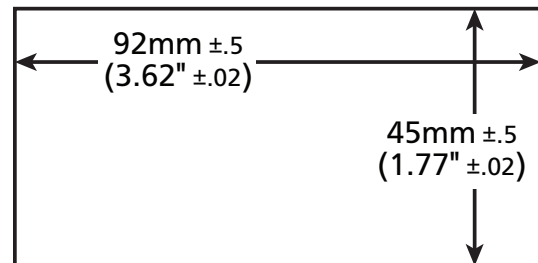

5

INPUT HEADER ADJUSTMENT

5.1 - Input header settings

The analog input board for the TEX-FLO10 has four headers which affect the Low Pass Filter (A), Mode (B), Input Signal (C) and Load (D). Of these, headers A, C and D should be adjusted as required for your sensor type. (Header B should always be set to 'Counter').

Refer to the tables below to determine whether the default header positions (highlighted black) are suitable for your application.

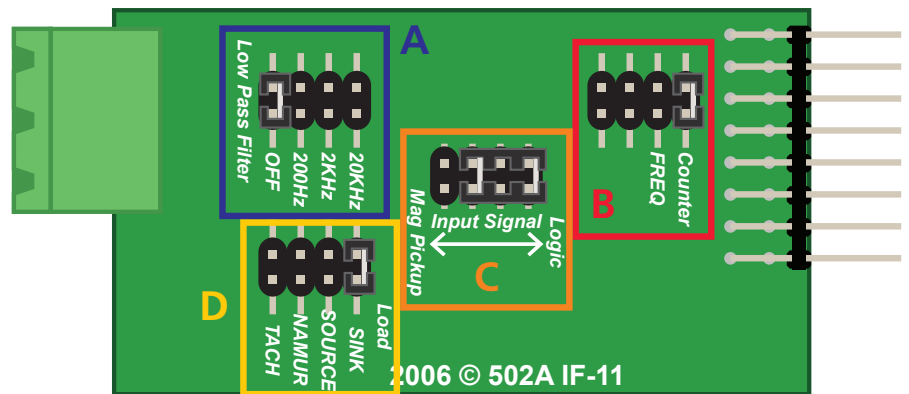

If required, follow the instructions in 5.2 to remove the analog input board from the meter case and adjust the header positions as needed.

Low Pass Filter Header (A)

OFF	Ideal for high-speed counting
200Hz	Ideal for mechanical contacts
2KHz	Suitable for a noisy signal
20KHz	Suitable for a noisy signal

Mode Header (B) - Do not adjust!

Counter	Always use this setting
FREQ	Not used for TEX-FLO10

Input Signal Header (C)

Logic	NPN, PNP, Namur, TTL & Pushbuttons
Mag Pickup	Tacho

Load Header (D)

SINK	NPN, TTL & Pushbuttons
SOURCE	PNP
NAMUR	Namur
TACH	Tacho

5.2 - How to remove the input module

- A** If the meter is already installed, remove it from the panel, and unplug all plugs from the back of the unit.
- B** Using a small screwdriver or similar implement, press downward into one of the slots at the rear of the case. This will disengage one of the tabs which holds the back plate on, allowing it to be gently levered away at one corner.
- C** Holding the loosened corner open with one hand, disengage the lever on the opposite slot (Fig 1).

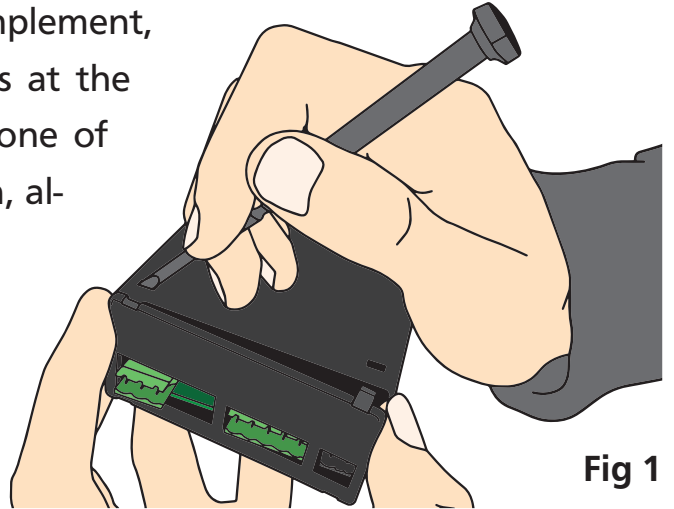

Fig 1

- D** You should now be able to remove the back plate. If it does not unclip easily, you may need to disengage the two remaining tabs by repeating steps 5.2B–C on the other side of the meter.

- E** Slide the analog input module out of the meter case (Fig 2). (See 3.1D to identify the input module.)

- F** Position the headers on the input module as required for your sensor type, referring to 5.1.

- G** Slide the input module back into the meter case.

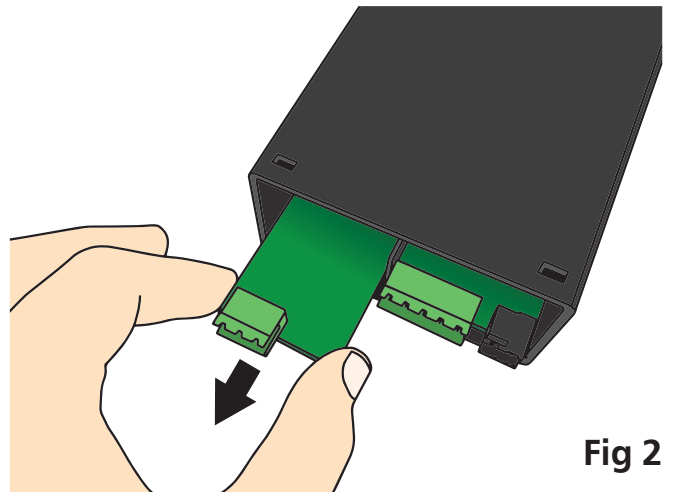

Fig 2

Make sure that it is sitting in the tracks on the left and right. Press firmly until the input module is fully inserted and sits flush with the other boards that are visible from the back of the meter.

- H** Replace the back plate.

Begin by inserting the two lower tabs into the slots, and then position the upper tabs so that they will not catch on the top lip of the meter case. Apply firm pressure until the back plate clicks into place.

- I** Reconnect the plugs and return the meter to the panel installation.

6

INPUT SETUP & CALIBRATION

6.1 - Enter F1 PIN number

A Enter the calibration mode by pressing the **F1** button.

___ ENTER F1 PIN NUMBER scrolls across the display and toggles with **0**. Use the **↑** and **↓** buttons to enter your security code (factory default 1). Then press **P**. If the correct PIN is entered, setup is started at 6.2.

If an incorrect PIN number is entered, **___ INCORRECT PIN NUMBER – ACCESS DENIED** scrolls across the display and it returns to normal operating mode.

You will have the opportunity to change your PIN number at the end of this section (6.9). If you have forgotten your PIN number, see Section 9.

6.2 - Flow rate setup



A **___ FLOW RATE SETUP** scrolls across the display and toggles with **SKIP**. Press **P** to skip to 6.3, or the **↑** button and then **P** to **ENTER** flow rate setup.

B **___ TIME UNITS FOR FLOW RATE** scrolls across the display and toggles with the currently selected time units. Use the **↑** and **↓** buttons to select **/SEC**, **/MIN** or **/HOUR**, and then press **P** to accept.

C **___ RESOLUTION FOR FLOW RATE** scrolls across the display and toggles with the currently selected decimal point position. Use the **↑** and **↓** buttons to select **1**, **0.1**, **0.01** or **0.001** units of flow, and then press **P** to accept and continue.

'Units of flow' are your selected engineering units (I.e. Litres, Gallons etc).

D **___ K FACTOR RANGE** scrolls across the display and toggles with the current selection. Use the **↑** and **↓** buttons to select the most suitable K factor range for your application: **99.9999**, **999.999** or **9999.99**. Then press **P**.

- E** **___ K FACTOR** scrolls across the display and toggles with the currently selected value. Use the  and  buttons to enter the K factor from your flow transducer manufacturer's specifications. Then press .

*If **___ ERROR – REDUCE INPUT RESOLUTION OR TIME** scrolls across the display, then the selection of K factor, time units or flow rate resolution has resulted in internal scale factors which exceed the limitations of the controller.*



To fix this, the setup returns to 6.2A, allowing you to select a lower display resolution or reduce the time units.

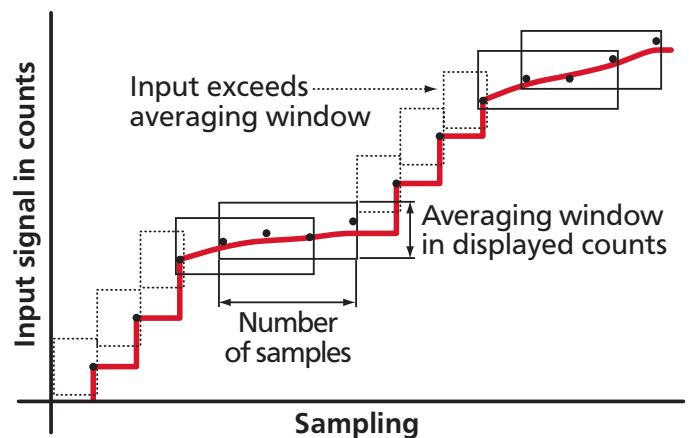

6.3 - Averaging

Your controller has input signal averaging, optimising stable measurement.



If the change in input exceeds the averaging window value it will not average, ensuring fast response when there are large differences between readings.



- A** **___ AVERAGING SETUP** scrolls across the display and toggles with **SKIP**. Press  to skip to 6.4, or the  button and then  to **ENTER** averaging setup.

- B** **___ AVE SAMPLES** scrolls across the display and toggles with the currently selected averaging. Using the  and  buttons, alter the number of input samples that the controller will average, and then press .

Increasing the number of samples will stabilise measurement, but it will also slow down response rates.

- C** **___ AVE WINDOW** scrolls across the display and toggles with the currently selected averaging window value. Using the  and  buttons, alter the signal averaging window. Then press .

*If your input signal contains large noise spikes, you can increase the size of the averaging window to ensure that these are still averaged. However, increasing the window size too far will reduce the ability of the controller to respond quickly to real changes in input signal. Setting **AVE WINDOW** to 0 will give continuous averaging as per the selected averaging samples.*

6.4 - Total 1 setup

Total 1 can be reset from the security protected **[F2]** menu (see 7.2B) or from a switch connected across the rear Total 1 and Common function pins (see 3.6).

A **___ TOTAL 1 SETUP** scrolls across the display and toggles with **SKIP**. Press **[P]** to skip to 6.5, or the **[↑]** button and then **[P]** to **ENTER** Total 1 setup.

B **___ RESOLUTION OF TOTAL 1 IN FLOW UNITS** scrolls across the display and toggles with the currently selected Total 1 resolution. Use the **[↑]** and **[↓]** buttons to select: **X0.1**, **X1**, **X10**, **X100** or **X1000**, and then press **[P]**.

'FLOW UNITS' are your selected engineering units (I.e. Litres, Gallons etc).

C **___ LOW FLOW LIMIT FOR TOTAL 1** scrolls across the display and toggles with the current low flow cutoff value. Inputs below this level will not affect the totalizer for Total 1. Adjust this value using the **[↑]** and **[↓]** buttons, and then press **[P]**. (To disable this feature, set the *Low Flow Limit* to 0.)

D **___ ROLL OVER-TOTAL 1** scrolls across the display and toggles with the current selection. Use the **[↑]** and **[↓]** buttons to choose between **OFF** and **ON**, and then press **[P]**.

This parameter controls the behaviour of the totalizer when it exceeds its maximum display value (999999 display counts). ON - The display will roll over to 0 once it passes its limit. OFF - The display will show OVER once it passes its limit, and will not roll over to 0.

E **___ BATCHING FROM PROG BUTTON** scrolls across the display and toggles with the current selection. Use the **[↑]** and **[↓]** buttons to select **OFF** or **ON**, and then press **[P]**. If this feature is activated, then when the **[P]** button is pressed for 2 seconds from the main display, the batch value will be reset to zero.

The batching function is used to display the difference in volume between the current total and the last batch operation. This allows the user to maintain the total in the background, while still allowing set batch amounts to be measured.

*Each time the batch function is activated from the **[P]** button (or the Batch function pin, see 3.6), the current value of Total 1 is loaded into the Batch Tare register so that the Batch Value equals zero (Batch Value = Total1 – Batch Tare).*

6.5 - Total 2 setup

Total 2 can be reset from the security protected **[F2]** button (see 7.2C) or from a switch connected across the rear Total 2 and Common function pins (see 3.6).

A **___ TOTAL 2 SETUP** scrolls across the display and toggles with **SKIP**. Press **[P]** to skip to 6.6, or the **[↑]** button and then **[P]** to **ENTER** Total 2 setup.

B **___ RESOLUTION OF TOTAL 2 IN FLOW UNITS** scrolls across the display and toggles with the currently selected Total 2 resolution. Use the **[↑]** and **[↓]** buttons to select: **X0.1**, **X1**, **X10**, **X100** or **X1000**, and then press **[P]**.

'FLOW UNITS' are your selected engineering units (I.e. Litres, Gallons etc).

C **___ LOW FLOW LIMIT FOR TOTAL 2** scrolls across the display and toggles with the current low flow cutoff value. Inputs below this level will not affect the totalizer for Total 2. Adjust this value using the **[↑]** and **[↓]** buttons, and then press **[P]**. (To disable this feature, set the *Low Flow Limit* to 0.)

D **___ ROLL OVER-TOTAL 2** scrolls across the display and toggles with the current selection. Use the **[↑]** and **[↓]** buttons to choose between **OFF** and **ON**, and then press **[P]**.

*This parameter controls the behaviour of the totalizer when it exceeds its maximum display value (999999 display counts). **ON** - The display will roll over to 0 once it passes its limit. **OFF** - The display will show **OVER** once it passes its limit, and will not roll over to 0.*

6.6 - Display setup

A **___ DISPLAY SETUP** scrolls across the display and toggles with **SKIP**. Press **[P]** to skip to 6.7, or the **[↑]** button and then **[P]** to **ENTER** display setup.

B **___ LINE 1 DISPLAY SOURCE** scrolls across the display and toggles with the currently selected display source for the main display. Use the **[↑]** and **[↓]** buttons to select: **FLOW**, **TOTAL1**, **TOTAL2** or **BATCH**, and then press **[P]**.

*Selecting **BATCH** will display the difference between the current Total 1 value, and the last batch operation. The batch function can be activated from the **[P]** button (see 6.4E) or the Batch function pin (see 3.6).*

6.7 - Analog output setup

A ___ **ANALOG OUTPUT SETUP** scrolls across the display and toggles with **SKIP**. If your controller does not have analog output installed, (or you do not wish to configure your analog output now), please press **P** to skip to 6.8.

Otherwise, press the **↑** button and then **P** to **ENTER** analog output setup.

B ___ **DATA SOURCE FOR ANALOG OUTPUT** scrolls across the display and toggles with the current analog output data source. Use the **↑** and **↓** buttons to select an option from: **FLOW**, **TOTAL1**, **TOTAL2** or **BATCH**, and then press **P**.

C ___ **LOW SCALE VALUE FOR ANALOG OUTPUT** scrolls across the display and toggles with the currently selected low scale value. Use the **↑** and **↓** buttons to enter your cal low position, and then press **P**.

*This sets the display value for **CAL LOW** (as in 6.7F, below).*

D ___ **HIGH SCALE VALUE FOR ANALOG OUTPUT** scrolls across the display and toggles with the currently selected high scale value. Use the **↑** and **↓** buttons to enter your cal high position, and then press **P**.

*This sets the display value for **CAL HIGH** (as in 6.7G, below).*

E ___ **CALIBRATE ANALOG OUTPUT?** scrolls across the display and toggles with **SKIP**. If you do not wish to calibrate your analog output then press **P** now to skip to 6.8.

To calibrate your analog output now, connect a mA or volt meter across the analog output connector (see 3.4). Then press the **↑** button, followed by **P**, to **ENTER** analog output calibration mode.

F ___ **CAL LOW ANALOG OUTPUT** scrolls across the display and toggles with a calibration number displayed in internal units (mA or V). Using the **↑** and **↓** buttons, calibrate your low analog output as required, and then press **P**.

G ___ **CAL HIGH ANALOG OUTPUT** scrolls across the display and toggles with a calibration number displayed in internal units (mA or V). Using the **↑** and **↓** buttons, calibrate your high analog output as required, and then press **P**.

6.8 - Serial setup

A ___ **SERIAL SETUP** scrolls across the display and toggles with **SKIP**. If your controller does not have a serial port installed, (or you do not wish to configure your serial options now), please press **P** to skip to 6.9.

Otherwise, press the **↑** button and then **P** to **ENTER** serial setup.

B ___ **SERIAL MODE** scrolls across the display and toggles with the currently selected serial mode. Using the **↑** and **↓** buttons, choose either: **ASCII** (custom ASCII), **MODBUS** (Modbus/RTU) or **RNGR A** (Ranger A). Then press **P**.

➔ If you selected **ASCII** or **MODBUS**, skip to 6.8D now.

➔ If you selected **RANGER A**, continue to 6.8C now.

See Appendix A for more information about the available serial modes.

C ___ **SERIAL DATA SOURCE** scrolls across the display and toggles with the current Range A serial data source. Use the **↑** and **↓** buttons to select an option from: **FLOW**, **TOTAL1**, **TOTAL2** or **BATCH**, and then press **P**.

D ___ **BAUD RATE** scrolls across the display and toggles with the current selection. Use the **↑** and **↓** buttons to select one of: **300**, **600**, **1200**, **2400**, **4800**, **9600**, **19200** or **38400**. Then press **P**.

E ___ **PARITY** scrolls across the display and toggles with the currently selected parity. Using the **↑** and **↓** buttons, select: **NONE**, **ODD** or **EVEN**, and then press **P**.

F ___ **SERIAL ADDRESS** scrolls across the display and toggles with the currently selected serial address. Use the **↑** and **↓** buttons to alter the serial address, and then press **P**.

*The serial address parameter is used to identify a particular device when it is used with other devices in a system. (It applies particularly to **MODBUS** mode when used on an RS485 serial network.) The serial address of the controller must be set to match the serial address defined in the master device.*

Refer to Appendix A for more information on serial modes and registers.

6.9 - Edit F1 PIN number

- A** **___ EDIT F1 PIN NUMBER?** scrolls across the display and toggles with **SKIP**. Press **P** to skip and return to the operational display, or the **↑** button and then **P** to **ENTER** and change your PIN number.
- B** **___ ENTER NEW F1 PIN NUMBER** scrolls across the display and toggles with the current PIN (default 1). Using the **↑** and **↓** buttons, enter your new F1 PIN number. Then press **P** to exit to the operational display.

7

TOTALIZER RESET & SETPOINT SETUP

The software in your controller will allow you to configure up to 6 setpoints, however full functionality is only supported by setpoints with relay output hardware installed.

(Setpoints with no corresponding relay output hardware may be used as simple LED indicators, if desired. In this case, features requiring relay output functionality will continue to appear in the setup menu, but will be ignored by the controller.)

7.1 - Enter F2 PIN number

- A** Enter setpoint setup mode by pressing and holding the **F2** button for 3 seconds. **___ ENTER F2 PIN NUMBER** scrolls across the display and toggles with **0**. Use the **↑** and **↓** buttons to enter your security code (factory default 1). Then press **P**. If the correct PIN is entered, setup is started at 7.2.
- If an incorrect PIN number is entered, **___ INCORRECT PIN NUMBER – ACCESS DENIED** scrolls across the display and it returns to normal operating mode.



You will have the opportunity to change your PIN number at the end of this section (7.4). If you have forgotten your PIN number, see Section 9.

7.2 - Reset totalizers

- A** ___ **RESET TOTALIZERS?** scrolls across the display and toggles with **SKIP**. Press **P** to skip to 7.3, or the **↑** button and then **P** to **ENTER** totalizer reset mode.
- B** ___ **RESET TOTAL 1** scrolls across the display and toggles with the current selection. Use the **↑** and **↓** buttons to select **YES** or **NO**, and press **P** to accept.
Selecting YES will reset Total 1 to zero.
- C** ___ **RESET TOTAL 2** scrolls across the display and toggles with the current selection. Use the **↑** and **↓** buttons to select **YES** or **NO**, and press **P** to accept.
Selecting YES will reset Total 2 to zero.
-

7.3 - Setpoint setup

- A** ___ **EDIT SETPOINT** scrolls across the display and toggles with **SKIP**. The software in your controller will allow you to configure up to 6 setpoints, however full functionality is only supported by setpoints with relay output hardware installed.
Press **P** now to skip to 7.4, or use the **↑** and **↓** buttons to select a setpoint to edit, and then press **P** to enter setpoint setup.
- B** ___ **SP SOURCE** scrolls across the display and toggles with the current setpoint activation source. Use the **↑** and **↓** buttons to select one of: **FLOW**, **TOTAL1**, **TOTAL2** or **BATCH**, and then press **P**.
- C** ___ **SP VALUE** scrolls across the display and toggles with the current value for the selected setpoint. Using the **↑** and **↓** buttons, adjust the display value at which the selected setpoint will activate, and then press **P**.
- D** ___ **SP ACTIVATION** scrolls across the display and toggles with the current activation for the selected setpoint. Using the **↑** and **↓** buttons, select the relay activation to operate **ABOVE** or **BELOW** the setpoint value, and then press **P**.
***ABOVE:** Relay turns on above the setpoint value and off below it. **BELOW:** Relay turns on below the setpoint value and off above it.*
-

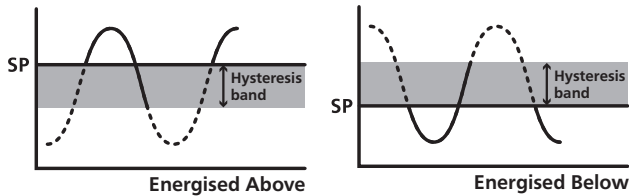

- E** ___ **HYSTERESIS TYPE** scrolls across the display and toggles with the currently selected hysteresis type. Using the  and  buttons, select either **ALARM** or **CNTRL** (control), and then press .

ALARM - SP VALUE controls setpoint activation point. **HYSTERESIS VALUE** controls setpoint deactivation point.



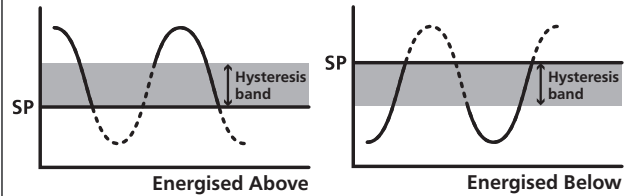

CNTRL - SP VALUE controls setpoint deactivation point. **HYSTERESIS VALUE** controls setpoint reactivation point.



- F** ___ **HYSTERESIS VALUE** scrolls across the display and toggles with the hysteresis value for the selected setpoint. Use the  and  buttons to adjust this value if required, and then press .



The **HYSTERESIS VALUE** defines the separation band between setpoint activation and deactivation, and will operate as per the **HYSTERESIS TYPE** setting selected in 7.3E.

- G** ___ **MAKE DELAY** scrolls across the display and toggles with the current delay value for the selected setpoint. Use the  and  buttons to adjust the delay value (in tenths of a second) as required, and then press .

This value defines the time delay between setpoint activation, and when the relay turns on. The time is 1/10'th second resolution.

- H** The step that you proceed to now will depend on what you selected as your setpoint source in 7.3B.



- ➔ If you selected **FLOW**, **TOTAL1**, or **BATCH**, skip to 7.3K now.
- ➔ If you selected **TOTAL2**, continue to 7.3I now.

- I** ___ **VOLUMETRIC PULSE** scrolls across the display and toggles with the current selection. Use the  and  buttons to select **OFF** or **ON**, and then press .



- ➔ If you selected **OFF**, skip to 7.3K now.
- ➔ If you selected **ON**, continue to 7.3J now.

This function outputs a pulse on the relay when **Total 2** \geq **Setpoint Value**. This will activate the selected relay for a specified length of time (see 7.3J), which can be adjusted in 0.1 second increments to suit the requirements of externally connected devices. This function is useful for feeding volume information to other equipment.

When the selected setpoint is activated in volumetric pulse mode, Total 2 will reset using the calculation: **Total** = **Total** – **Setpoint Value**, and then resume totalizing.

J **___ PULSE TIME** scrolls across the display and toggles with the current selection. Use the  and  buttons to select your pulse time (from 0.1 to 10.0 seconds), and then press .



Pulse reset requires a minimum of 0.1 seconds. A combination of high input rates and low setpoint values may exceed this limitation, resulting in missed output pulses.

K **___ OPEN ACCESS TO SP VALUE** scrolls across the display and toggles with the current direct access permission setting for the selected setpoint. Use the  and  to select either **YES** or **NO**, and then press .

When enabled, this option allows the selected setpoint's value to be edited directly after pressing the  button, without needing to enter a PIN number or go through all of the other options. Each setpoint can individually have this option enabled or disabled. See Section 8.

L The step that you proceed to now will depend on which setpoint you are editing.



- ➔ If you are currently editing **SP 1**, skip to 7.3N now.
- ➔ If you currently editing **SP 2–6**, continue to 7.3M now.



M **___ TRAIL SP 1** scrolls across the display and toggles with the current trailing setting for the selected setpoint. Use the  and  buttons to select **OFF** or **ON**, and press .

*If you choose **ON**, the selected setpoint will track the setpoint value of **SP 1**, with the setpoint value of the tracking setpoint becoming an offset value.*

N **___ EDIT SETPOINT** scrolls across the display and toggles with **SKIP**. You are now back at 7.3A. To edit another setpoint, follow the instructions from 7.3A–N again. If you do not wish to edit another setpoint, press  now to skip to 7.4.

7.4 - Edit F2 PIN number

A **___ EDIT F2 PIN NUMBER?** scrolls across the display and toggles with **SKIP**. Press  to skip and return to the operational display, or the  button and then  to **ENTER** and change your PIN number.

B **___ ENTER NEW F2 PIN NUMBER** scrolls across the display and toggles with the current PIN (default 1). Using the  and  buttons, enter your new F2 PIN number. Then press  to exit to the operational display.

8

SETPOINT DIRECT ACCESS

If none of the setpoints have their direct access option enabled then this feature will be disabled and the **F2** button will not respond to a short button press. (See 7.3K.)

- A Begin by pressing the **F2** button for less than 3 seconds.
- B The name of the first access-enabled setpoint will appear on the display and toggle with the current value for that setpoint. Using the **↑** and **↓** buttons, adjust the selected value. Then press **P** to accept and continue.
- C The name of the next access-enabled setpoint will appear on the display, along with its setpoint value. Repeat step 8B. The direct access menu will proceed through all access-enabled setpoints in this fashion. Pressing **P** for the last enabled setpoint will exit and return to the operational display.

9

RESET PIN NUMBERS / VIEW FIRMWARE VERSION

If you have forgotten your PIN number(s), follow the procedure below to reset both the Calibration and Setpoint PINs to their factory default of 1.

This procedure will also allow you to view the current software installed on your device, which may be required for support purposes.

- A Press **↑**, **↓** and **P** at the same time. (This key combination can be difficult to execute and you may need several tries to get it right.)
- B A message will appear on the display, with details of the unit's current software configuration (Product name, Firmware Version, and Macro Version). At the end, you will see – **ALL PIN NUMBERS RESET TO 1**
- C Both the F1 PIN number and the F2 PIN number have now been reset to '1'. You can change this, if required, by following the instructions in 6.9 (for F1) and 7.4 (for F2), using '1' to enter each menu initially.

A.1 - Custom ASCII mode

Custom ASCII is a simple, custom protocol that allows connection to various PC configuration tools. ('Custom ASCII' differs from the 'Modbus (ASCII)' protocol used by some devices.) Custom ASCII command strings must be constructed in this order:

**<Start> <Controller Address> <Read/Write Command> <Register Address>
<Separator Character> <Data Value> <Message Terminator>**

Start - Use 'S' for the start character of a command string (not case sensitive). This must be the first character in the string.

Controller Address - Use an ASCII number from '1' to '255' for the controller address. If the character following the start character is not an ASCII number, then address '0' is assumed. All controllers respond to address '0'.

Read/Write Command - Use ASCII 'R' for read, 'U' for unformatted read, or 'W' for write (not case sensitive). Any other character aborts the operation.

In Custom ASCII mode, data is normally read as formatted data (which includes decimals and any text characters that may be selected to show units). However it is also possible to read unformatted data by using a 'U' in the read command. There is no unformatted write command, as when writing to fixed point registers, any decimal point and text characters are ignored.

Register Address - The register address for the read/write operation will be an ASCII number from '1' to '65535'. This character must be specified for a write command, but may be omitted for a read command, (in which case the controller will respond with the data value currently on the display).

Separator Character - The separator character can be either a space or a comma, and is used to separate the register address from the data value.

Data Value - Must be an ASCII number. The absolute limits for this number are -1000000 to 1000000, but please note that not all registers will accept this range.

Message Terminator - This is the last character, and must be either a '\$' (dollar) or an '*' (asterisk). Neither of these characters should be used elsewhere in the

message string. If '\$' is used, a 50ms minimum delay is inserted before a reply is sent. If '*' is used, a 2ms minimum delay is inserted before a reply is sent.

Custom ASCII Read/Write Examples

Example	Description
SR\$	Read display value from all controllers, 50ms delay.
S15R\$	Read display value from controller address 15, 50ms delay.
S3U40*	Read unformatted data in channel 4 from controller address 3, 2ms delay.
S2W2 -10000\$	Write -10000 to the display register of controller address 2, 50ms delay.
SWT CHAN_1\$	Write ASCII text string Chan_1 to channel 1 text register, 50ms delay.

Custom ASCII Registers

16 Bit Unsigned

Address	Function
1	Alarm status (Bit 0=SP1, Bit 1=SP2, Bit 2 =SP3, Bit 3=SP4 etc.)
65	Hysteresis SP1
66	Hysteresis SP2
67	Hysteresis SP3
68	Hysteresis SP4
71	Make delay SP1
72	Make delay SP2
73	Make delay SP3
74	Make delay SP4

32 Bit Signed

Address	Function
2	Process display
3	Batch result
4	Flow rate
16	Total 1
17	Total 2
6	Setpoint 1
7	Setpoint 2
8	Setpoint 3
9	Setpoint 4
34	D/A scale low value
36	D/A scale high value

Controller Response - After the controller has completed a read or write instruction, it responds by sending a carriage return/line feed (CR/LF) back to the host. If the instruction was a read command, the CR/LF follows the last character in the ASCII string. If it was a write command, CR/LF is the only response sent back. The host must wait for this before sending further commands to the controller. If the controller encounters an error, it will respond with a null (0x00) CR/LF.

A.2 - Modbus (RTU) mode

Modbus (RTU) is an industry standard RTU slave mode that allows connection to a wide range of devices. Modbus registers are all holding registers, and should be accessed via function codes 3 and 6.

Register addresses are displayed in the Modicon™ 5-digit addressing format. I.e. Register 65=40065 (subtract 1 for direct addressing).

Modbus (RTU) Registers

16 Bit Unsigned		32 Bit Signed (2 x 16 Bit)		
Address	Function	LSW	MSW	Function
40001	Alarm status (Bit 0=SP1, Bit 1=SP2, Bit 2 =SP3, Bit 3=SP4)	40513	(40514)	Process display
40065	Hysteresis SP1	40515	(40516)	Batch result
40066	Hysteresis SP2	40517	(40518)	Flow rate
40067	Hysteresis SP3	40529	(40530)	Total 1
40068	Hysteresis SP4	40531	(40532)	Total 2
40071	Make delay SP1	40535	(40536)	Setpoint 1
40072	Make delay SP2	40537	(40538)	Setpoint 2
40073	Make delay SP3	40539	(40540)	Setpoint 3
40074	Make delay SP4	40541	(40542)	Setpoint 4
		40587	(40588)	D/A scale low value
		40591	(40592)	D/A scale high value

A.3 - Ranger A mode

Ranger A is a continuous output, used to drive remote displays and other instruments in the Rinstrum™ range. (Ranger is a trade name belonging to Rinstrum Pty Ltd.) Ranger A output strings are constructed as shown:

<Start> <Sign> <Output Value> <Status> <End>

Start - STX character (ASCII 02)

Sign - Output value sign (space for + and dash for -)

Output Value - Seven character ASCII string containing the current output value and decimal point. (If there is no decimal point, then the first character is a space. Leading zero blanking applies.)

Status - Single character output value status. 'U'=Under, 'O'=Over, 'E'=Error.

End - ETX character (ASCII 03)



Define Instruments

New Zealand (Head Office)

 10B Vega Place, Rosedale,
Auckland 0632, New Zealand
PO Box 245 Westpark Village,
Auckland 0661, New Zealand

Ph: +64 (9) 835-1550 | **Aus:** 1800 810-820

Fax: +64 (9) 835-1250

 sales@defineinstruments.co.nz

www.defineinstruments.co.nz

United States (Dallas, TX)

Ph: 214.926.4950

 sales@defineinstruments.com

www.defineinstruments.com

South Africa (Pretoria)

Ph: 087 945 2700

 sales@defineinstruments.co.za

www.defineinstruments.co.za